

Prepared by: Jennifer Yorke (Hons Kin)
Completed: August 18, 2006

Electrician's Job Demands Literature Review – Ladders

An electrician's job requires daily use of climbing devices such as ladders. Ladders are employed in all five sectors of electrical work. With increased use, comes the potential for injury. Chengalur et al. (2004) reported that falls from ladders are one of the leading causes of injury and death in the United States. Ergonomic and biomechanical factors are a contributing factor in worker falls, therefore identifying correct biomechanical parameters of ladder construction and use could potentially reduce worker injuries and falls (Kumar, 2001). Safety training can also assist in reducing the number of injuries and falls associated with ladders (NIOSH, 2004).

Potential Injuries & Biomechanics of Ladder Use

(Only male subjects were analyzed)

Slips and Falls:

Slips and falls are a major cause of work related injuries. In 1999, the Canadian Centre for Occupational Health and Safety (CCOHS) reported that approximately 40% of all falls occur from a height. CCOHS (2005) research attributes a majority of slips and falls to a loss of balance as a result of an "unexpected change in the contact between the feet and the ground." With elevated slips and falls, the resulting change in ground contact can refer to the ladder base and the floor. Therefore correct placement of a ladder on even ground, free of obstructions and debris and well-maintained, clean ladders reduce the potential for falls and subsequent injury (Christensen & Cooper, 2005). Workers must also use caution when ascending and descending a ladder as workers exert less ladder control when climbing quickly (Kumar, 2001).

Centre of Mass & Base of Support:

Center of mass, also referred to as centre of gravity, is defined as a point within the body at which an individual's mass seems to concentrate around (Wikipedia, 2006). Centre of mass is critical to the maintenance of balance. An individual will remain balanced as long as their centre of mass is within their base of support. When an individual is standing, their base of support is the area around their feet. The wider their feet are spaced apart, the larger their base of support and the greater their postural stability (University of Illinois, 1998).

In order to maintain postural stability, one's centre of mass must be within their base of support. Lehtola et al. (2004) reported a frequent cause of ladder related injuries is from reaching too far to the left or right when working on a ladder. A majority of work on ladders is done with overhead obstructions resulting in workers being placed in awkward positions that can fall outside of their base of support. Tsipouras et al. (2001) also reported in their study of 163 documented fall patients, 43% of accidents occurred from ladder instability due to workers reaching beyond a ladder's edge to accomplish a task.

Prepared by: Jennifer Yorke (Hons Kin)
Completed: August 18, 2006

The University of Illinois (1998) also reported that vision is a factor in maintaining postural support. CCOHS (2005) recommends lighting levels to be a minimum of 50 lux to prevent falls and slips.

The following describes the effect of ladder use on various body segments:

Hands

(Kumar, 2001 & Bloswick and Chaffin, 1990)

The hands are used primarily to balance the body when ascending or descending a ladder. The total peak two-handed force was approximately 25% of a climber's body weight. The force on the hands increases as the ladder slant is raised from 70 to 90 degrees and as the rung separation becomes greater. A potential risk of hand slip is possible as the maximum one-hand force increases to 35% of maximum grip strength if ladder rungs are slippery or wet.

Elbow & Shoulder

(Kumar, 2001 & Bloswick and Chaffin, 1990)

During vertical ladder use the peak elbow flexion moment was 45% of its maximum producible static moment while that peak shoulder extension moment was 15% of its maximum producible static moment. The average shoulder moment was 5% of static maximum. All measured forces were of very short duration and carry a low risk of injury.

Hip & Knee

(Kumar, 2001 & Bloswick and Chaffin, 1990)

Maximum hip flexion was measured at 55 degrees and maximum knee flexion was 70 degrees during ladder use.

Feet

(Kumar, 2001 & Bloswick and Chaffin, 1990)

The average force on one foot while ascending and descending a ladder ranged from 48-64% of a climber's body weight with a maximum force of 85% and varies according to the slant of the ladder. Foot slip potential is highest during vertical ladder use, as the coefficient of friction is lowest (0.4).

Spine

(Kumar, 2001; Bloswick and Chaffin, 1990; Rodgers et al., 1986)

When climbing ladders, measured estimates of shear, compression and total forces on the low back (L5/S1) were below the NIOSH action limit of 3400 N and the NIOSH maximum permissible limit of 6400 N in Bloswick & Chaffin's 1990 research.

Erector spinae activity was measured to be approximately 65% of static maximum force production and increased as the slant of the ladder was raised from 70 to 90 degrees. Peak erector spinae IEMG measurements approached 100% of static maximum force production as climbing speed increased during the use of vertical ladders, which indicates a potential for injury to the low back.

Prepared by: Jennifer Yorke (Hons Kin)
Completed: August 18, 2006

Ladder Design & Recommended Ladder Parameters

(Please see Appendix for figures)

This review refers to two types of rigid, portable ladders: extension ladders and step ladders. Electricians usually employ ladders in 4 – 12 foot lengths, although longer ladders may be used for certain jobs and are made of metal or wood. Ladder steps are called rungs. Rigid ladders are usually portable, but some may be fixed to buildings.

Parameter	Recommendation	Source
Slope of ladder use	70+ degrees (70 degrees is optimal)	Chengalur et al. (2004); NIOSH (1997); Kumar (2001)
Rung separation	10 – 12 inches (> 14 in. is 'fatiguing')	Chengalur et al. (2004); NIOSH (1997); Kumar (2001)
Rung diameter	0.75 – 1.5 inches (1.125 inches – wood)	NIOSH (1997); Kumar (2001)
Rung width	15 – 24 inches	Chengalur et al. (2004); NIOSH (1997), Kumar (2001)
Rung type	Flat on top & able to accept the midpoint of the foot	NIOSH (1997)
Toe depth	3+ inches	Chengalur et al. (2004)
Ladder clearance	30 – 36 inches	NIOSH (1997)
Ladder material	Wood or metal	Kumar (2001)
Other	Tie off when 3+ meters off the ground to prevent fall injuries	CCOHS (2005)

Further Recommendations on Ladder Use

NIOSH (1997) also states that the first step off the ground to the bottom rung of the ladder must be reachable by the shortest person working on site. Two handholds must also be reachable from the ground allowing for all workers to begin their ascension with three points of contact to the ladder. Three points of contact are recommended while ascending or descending a ladder, however Kumar et al. (2001) reported extended periods in a worker's gait pattern when only two points of contact occur. Bloswick & Chaffin (1990), referenced in Kumar (2001), reported a decrease in workers' control of a ladder when ascending and descending during fast climbing. Therefore workers should maintain a steady, slower pace when ascending or descending a ladder.

Prepared by: Jennifer Yorke B. Sc. (Hon. Kin.)
Supervised by: Syed Naqvi – PhD CCPE CPE (Ergonomist, OHCOW Inc.), David Mijatovic – BSc MHSc (Ergonomist, OHCOW Inc.) & Gary Majesky (IBEW L.U. 353)

Appendix

Table: Static Work Duration as a Function of Intensity (Rodgers et al., 1986)

Percent of Maximum Static Strength	Maximum Endurance Time
100	6 seconds
75	21 seconds
50	1 minute
25	3.4 minutes
15	>4 minutes

Figure: Vertical Ladder Design (NIOSH, 1997)

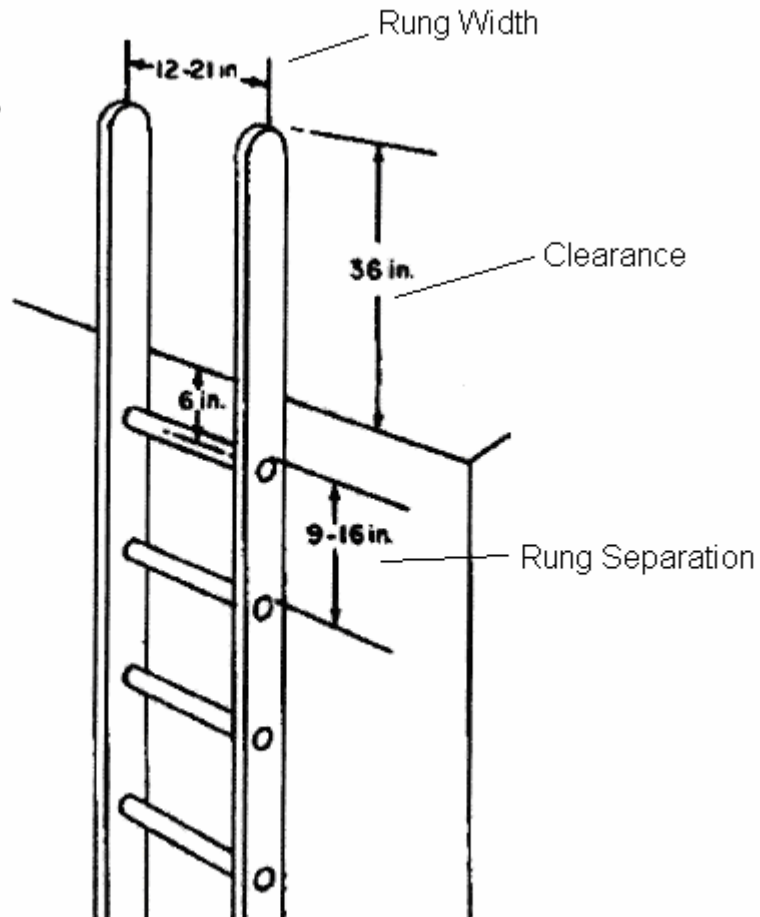
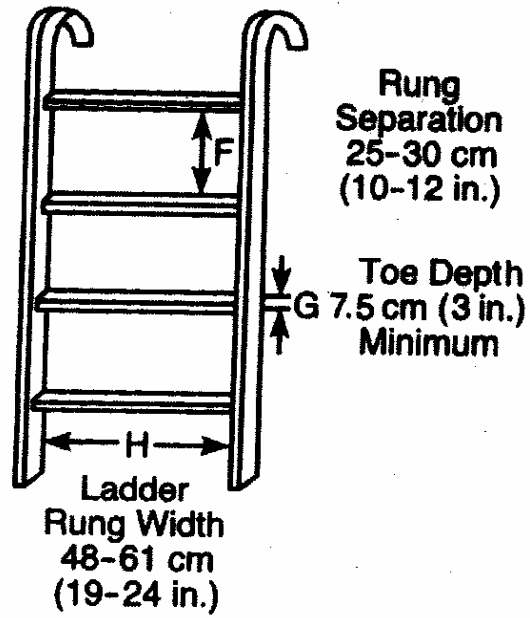

Figure 6 - Vertical ladder design. (2)

Prepared by: Jennifer Yorke (Hons Kin)
Completed: August 18, 2006

Figure: Design of Ladder (Chengalur et al., 2001)



Prepared by: Jennifer Yorke (Hons Kin)
Completed: August 18, 2006

Ladder Work Photographs



Prepared by: Jennifer Yorke (Hons Kin)
Completed: August 18, 2006

References

- Bloswick, D. & Chaffin, D. (1990). An Ergonomic Analysis of the Ladder Climbing Activity. *International Journal of Industrial Ergonomics*, 6, 17-27.
- Canadian Center for Occupational Health and Safety (2005, May 25). *Ladder Ergonomics*. Retrieved July 5, 2006, from <http://www.ccohs.ca/oshanswers/ergonomics/ladders.html>
- Canadian Centre for Occupational Health and Safety (2005, June 16). *Why Do We Need to Worry So Much About Falls on Stairs?* Retrieved July 7, 2006 from http://www.ccohs.ca/oshanswers/safety_haz/stairs_fallprevention.html
- Canadian Centre for Occupational Health and Safety (1999, June 10). *Why is the Prevention of Slips, Trips and Falls Important?* Retrieved July 7, 2006 from http://www.ccohs.ca/oshanswers/safety_haz/falls.html
- Chengalur, S.N., Rodgers, S. & Bernard, T. (2004). *Kodak's Ergonomic Design for People at Work*. New York: John Wiley & Sons, Inc.
- Christensen, T. & Cooper, N. [Occupational Hazards Safety Zone] (2005, November 21). *Attacking Ladder Falls One Rung at a Time*. Retrieved July 7, 2006 from http://www.occupationalhazards.com/safety_zones/37/article.php?id=14333
- Hanna, A. S., Menches, C.L., Sullivan, K.T. & Sargent, J. (2005). Factors affecting absenteeism in electrical construction. *Journal of Construction Engineering and Management*, 131, 1212-1218.
- Kumar, S. (2001). *Biomechanics in Ergonomics*. Philadelphia: Taylor & Francis Ltd.
- Lehtola, C., Becker, W. & Brown, C. [National AG Safety Database – University of Florida] (2004, July). *Preventing Injuries from Slips, Trips and Falls*. Retrieved July 7, 2006 from <http://www.cdc.gov/nasd/docs/d000001-000100/d000006/d000006.html>
- McGill, S. (2002). *Low Back Disorders: Evidence-Based Prevention and Rehabilitation*. Ontario: Human Kinetics.
- National Institution for Occupational Safety and Health (1997). *Design Recommendations for Catwalks, Ladders and Stairs*. Retrieved July 5, 2006 from http://www.cdc.gov/niosh/pot_wlk2.html
- National Institution for Occupational Safety and Health (2004). *Portable Ladders for Construction Self-Inspection Checklist*. Retrieved July 5, 2006 from <http://www.cdc.gov/niosh/docs/2004-101/chklists/r1n731~1.htm>

Prepared by: Jennifer Yorke (Hons Kin)

Completed: August 18, 2006

Occupational Health Clinics for Ontario Workers (2006). *Discomfort Survey Results*.

Retrieved August 3, 2006 from <http://www.ibew353.org/survey%20results.pdf>

Rodgers, S., Kenworthy, D., Eggleton, E., Kiser, D., Murphy, T. & Nielson, W. (1986). *Ergonomic Design for People at Work*. New York: Van Nostrand Reinhold.

Tsipouras, S., Hendrie, J. & Silvapulle, M. (2001). Ladders: Accidents Waiting to Happen. *Medical Journal of Australia*, 174, 516-519.

University of Illinois.(1998). *Postural Control*. Retrieved on July 10, 2006 from

http://www.kines.uiuc.edu/kines-courses/kines-257/Laboratory_files/257Lab4.html

Wikipedia. (2006, July 10). *Centre of Mass*. Retrieved on July 10, 2006 from

http://en.wikipedia.org/wiki/Center_of_gravity