

Construction Health and Safety Manual

**Construction Safety Association of Ontario
21 Voyager Court South, Etobicoke, Ontario M9W 5M7 Canada
(416) 674-2726 • 1-800-781-2726 • Fax: (416) 674-8866
info@csao.org • www.csao.org**

This revised edition includes updated information on electricity, trenching, legal responsibilities, and first aid, as well as corrections to the previous edition.

Developed by trade labour-management health and safety committees, this manual is fully a document of accord between labour and management authorities.

In the past, members of the public have used printed information that was outdated by subsequent improvements in knowledge and technology. We therefore make the following statement for their protection in future.

The information presented here is, to the best of our knowledge, current at time of printing and is intended for general application. This publication is not a definitive guide to government regulations or to practices and procedures wholly applicable under every circumstance. The appropriate regulations and statutes should be consulted. Although the Construction Safety Association of Ontario cannot guarantee the accuracy of, nor assume liability for, the information presented here, we are pleased to answer individual requests for counselling and advice.



Labour-Management

The Construction Safety Association of Ontario thanks the members of the Labour-Management Health and Safety Committees who contributed their knowledge, experience, and time in preparing this manual.

© Construction Safety Association of Ontario

ISBN-13: 978-0-919465-54-1

New edition 2003

Revised February 2004

Revised December 2004

Revised September 2006

Revised May 2007

Revised April 2008

Second printing, October 2008

Third printing, May 2009

CONTENTS

Legal Responsibilities and Emergencies

- Chapter 1 Legal responsibilities
- Chapter 2 Emergency procedures

Health

- Chapter 3 WHMIS
- Chapter 4 First aid
- Chapter 5 Basic occupational health
- Chapter 6 Heat stress
- Chapter 7 Cold stress
- Chapter 8 Back care
- Chapter 9 Moulds

Equipment

- Chapter 10 Personal protective equipment (PPE)
- Chapter 11 Eye protection
- Chapter 12 Head protection
- Chapter 13 Foot protection
- Chapter 14 Hearing protection
- Chapter 15 Respiratory protection
- Chapter 16 Hand/skin protection
- Chapter 17 High visibility clothing
- Chapter 18 Guardrails
- Chapter 19 Personal fall protection
- Chapter 20 Ladders
- Chapter 21 Scaffolds
- Chapter 22 Elevating work platforms
- Chapter 23 Suspended access equipment
- Chapter 24 Rigging

Hazards

- Chapter 25 Housekeeping and fire safety
- Chapter 26 Electrical hazards
- Chapter 27 Lockout and tagging
- Chapter 28 Backing up
- Chapter 29 Traffic control
- Chapter 30 Mounting and dismounting

-
- Chapter 31 Trenching
 - Chapter 32 Propane
 - Chapter 33 Confined spaces
 - Chapter 34 Asbestos
 - Chapter 35 Water and ice

Tools & Techniques

- Chapter 36 Hand tools
- Chapter 37 Power tools – drills, planes, routers
- Chapter 38 Power tools – saws
- Chapter 39 Power tools – air
- Chapter 40 Power tools – explosive
- Chapter 41 Welding and cutting
- Chapter 42 Formwork
- Chapter 43 Rodwork

**Legal
Responsibilities
and
Emergencies**

1 LEGAL RESPONSIBILITIES

General

The health and safety responsibilities of all parties on a construction project are specified in the current *Occupational Health and Safety Act and Regulations for Construction Projects*.

Responsibilities are prescribed in particular for constructor, employer, supervisor, and worker. Each party has specific responsibilities to fulfill on a construction project.

For more detailed information, consult the current Act and Regulations.

Remember — safety begins with you!

Constructor

- Appoint a supervisor if 5 or more workers are on the project at the same time. Ensure that the project is supervised at all times.
- A project that lasts more than 3 months and has 20 or more workers must have a Joint Health and Safety Committee.
- If a Joint Health and Safety Committee is not required and there are more than 5 workers, the workers must select a Health and Safety Representative.
- Complete a Ministry of Labour (MOL) registration form.
- Keep a copy of all employer-approved registration forms on site while employers are on the project.
- Send a notification of project to the MOL.
- Develop written emergency procedures, make sure your employees know what they are, and post them on site.
- Ensure ready access to a telephone, two-way radio, or other system in the event of an emergency.
- Report a fatality, critical injury, or other prescribed incident such as a critical injury to the MOL.
- Ensure all workers on site are at least 16 years of age.

Employer

- Read Sections 25 and 26 of the *Occupational Health and Safety Act*. It lists many of your responsibilities.
- Appoint a supervisor if 5 or more of the employer's workers are on the project at the same time. Ensure that they are supervised at all times.
- Provide workers with training as required by law (e.g., fall protection systems, WHMIS, etc.).
- Ensure workers are qualified to do work which must be done only by qualified workers (e.g., electricians, pipe fitters, etc.).
- Develop written procedures for rescuing a worker whose fall has been arrested (a worker hanging by a harness).

Supervisor

Supervisors must ensure that workers

- use the methods, procedures, and equipment required by the *Occupational Health and Safety Act and Regulations for Construction Projects*.

- use or wear the equipment or clothing that the employer requires
- Supervisors must also
- tell workers about actual or potential dangers
 - give workers written instructions when required
 - take every precaution reasonable to protect workers.

Worker

- Select worker representatives for the Joint Health and Safety Committee.
- Tell your supervisor or employer about equipment problems or other hazards that could hurt you or other workers.
- You have the right to refuse work that you believe endangers your health or safety — or the health or safety of others. See Section 43 of the *Occupational Health and Safety Act*.
- Follow your employer's instructions to use or wear equipment, protective devices, or clothing.
- Never engage in horseplay on site (pranks, competitions, showing off your strength, roughhousing, or unnecessary running).

Health and Safety Representative

The health and safety representative must be familiar with

- the current *Occupational Health and Safety Act and Regulations for Construction Projects*
- procedures in the event of an emergency (see chapter on Emergency Procedures in this manual)
- procedures for refusal to work where health and safety are in danger (Figure 1).

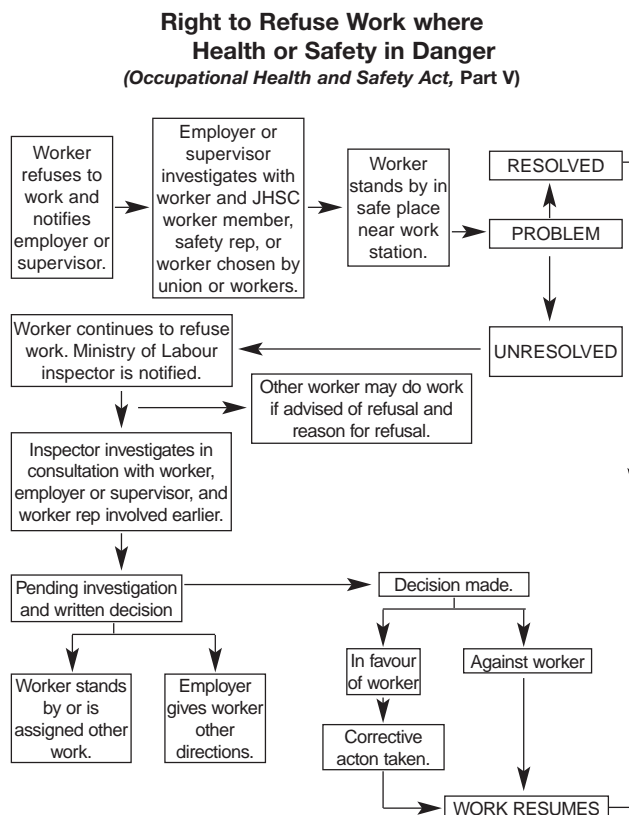


Figure 1

Accidents and Injuries

All accidents and injuries, regardless of severity, must be reported immediately.

Procedures for reporting accidents — and the type of accidents that must be reported — are spelled out in the *Occupational Health and Safety Act and Regulations for Construction Projects*.

Further information is available from the Workplace Safety and Insurance Board and Ministry of Labour.

Certified Committee Members

Where a project regularly employs 50 or more workers, the health and safety committee on the project must have at least one member representing workers and one member representing the constructor who are certified by the Workplace Safety and Insurance Board (Figure 2).

If no members of a health and safety committee are

certified, the workers and constructor must each select one member of the committee to become certified.

A certified member who receives a complaint regarding a dangerous circumstance can investigate the complaint under the authority of the *Occupational Health and Safety Act*. The member may also ask a supervisor to investigate a situation where the member “has reason to believe” that a dangerous circumstance may exist.

The supervisor must investigate the situation promptly in the presence of the certified member.

The certified member may also request that another certified member representing the other party at the workplace investigate the situation if the first certified member “has reason to believe” that the dangerous circumstance still exists after the supervisor’s investigation and remedial action, if any, has been taken.

The second certified member must promptly investigate the situation in the presence of the first certified member

Health and Safety Representatives and Committee Requirements Under the *Occupational Health and Safety Act*

Size and Duration of Project	Representative or Committee	Who Creates Committee	Number of Members	Membership Requirements	Selection of Members	Powers and Rights
5 Workers or Less						
6-19 workers and more than 3 months or 6+ workers and less than 3 months	One Health and Safety Representative				Representative selected by workers or union(s)	<ul style="list-style-type: none"> Obtain information from a constructor or employer regarding the testing of equipment, materials, or chemicals in the workplace. Inspect the workplace at least once a month, with the full cooperation of constructor, employers, and workers. Ask for and obtain information regarding existing or potential hazards in the workplace. Make health and safety recommendations to a constructor or employer, who must respond in writing within 21 days, either giving a timetable for implementation or giving reasons for disagreeing with the recommendations. Where a person has been killed or critically injured in the workplace, investigate the circumstances of the accident and report findings to a director of the Ministry of Labour. Exercise all the powers granted to the health and safety representative by virtue of a collective agreement.
20-49 workers and more than 3 months	Joint Health and Safety Committee	Constructor	At least two	At least one non-management worker at the project and one management representative from the project if possible.	Worker representatives selected from the site by workers or trade union(s) represented. Management representatives selected by constructor or employer.	<ul style="list-style-type: none"> Identify situations that may be a source of danger or hazard to workers. Make recommendations regarding health and safety matters. Recommend the establishment, maintenance, and monitoring of programs.
50+ workers and more than 3 months	Joint Health and Safety Committee	Constructor	At least four	Half non-management workers from the workplace with at least one certified. Half management representatives from the workplace if possible with at least one certified.	Worker representatives selected from the site by workers or trade union(s) represented. Management representatives selected by constructor or employer.	<ul style="list-style-type: none"> Obtain information from constructors or employers regarding testing of equipment or environments and be present when testing is initiated.
	Worker Trades Committee	Health and Safety Committee	At least one worker representative from each trade	One worker representative from each trade.	Members to be selected by trade workers or trade union(s) at the site. Members do not have to be workers at the site.	Advise the joint health and safety committee of the health and safety concerns of the workers in the trades at the workplace.

Figure 2

and, if both certified members agree, they may direct the constructor or employer to stop work or stop the use of any part of the workplace, including machines and other equipment. The constructor or employer must immediately comply with the order.

If both certified members do not agree that a dangerous circumstance exists, either may request that a Ministry of Labour inspector investigate the situation. The inspector must investigate and provide both members with a written report.

Ministry of Labour Inspectors

The inspector can visit a site at any time and exercise fairly broad powers to inspect, ask questions, and give orders. If the inspector approaches a worker directly, the worker must answer questions and cooperate. The supervisor must be informed of any orders given or recommendations made.

In some cases the health and safety representative, worker member of a health and safety committee, or worker selected by fellow workers or the union has a right to take part in accident investigation.

The results of accident investigation and reporting should be made known to all personnel on site. Recommendations should be implemented to prevent the accident from happening again.

In all cases of injury, the **EMPLOYER** must do the following.

1. Make sure that first aid is given immediately, as required by law.
2. Record the first aid treatment or advice given to the worker.
3. Complete and give to the worker a Treatment Memorandum (Form 156) if health care is needed.
4. Provide immediate transportation to a hospital or a physician's office, if necessary.
5. Submit to the Workplace Safety and Insurance Board (WSIB), within three days of learning of an accident, an Employer's Report of an Accident/Injury/Industrial Disease (Form 7) and any other information that may be required.
6. Pay full wages and benefits for the day or shift on which the injury occurred when compensation is payable for loss of earnings.
7. Notify the Ministry of Labour, health and safety representative and/or committee, and union as required by legislation.

The **WORKER** must do the following.

1. Promptly obtain first aid.
2. Notify the employer, foreman, supervisor, and worker safety representative immediately of an injury requiring health care and obtain from the employer a completed Treatment Memorandum (Form 156) to take to the physician or the hospital. Failure to report promptly can affect your benefits and subject your employer to fines.

3. Choose a physician or other qualified practitioner with the understanding that a change of physician cannot be made without permission of the WSIB.
4. Complete and promptly return all report forms received from the WSIB.

New Hires

Statistics show that about 20% of all injuries to workers occur within their first 30 days on the job. This fact highlights the importance of orientation.

The new hire may be young or old, male or female, experienced or inexperienced in construction. The worker may be new to the site, new to the type of work, or new to the company. A worker coming to any project for the first time should be considered a "new hire."

New employees must be told and, if necessary, trained and shown what is expected of them in

- work performance
- safe operation of tools and equipment
- procedures around hazardous materials
- proper use of any required personal protective clothing and equipment.

They must also be told, and preferably shown, the location of

- first aid kit or first aid station
- fire alarms and exits
- fire extinguishers and standpipes
- emergency telephones
- eyewash station
- supervisor's office
- tool crib
- washrooms
- lunchroom.

These locations can be pointed out during a tour of the workplace when the new hire is introduced to co-workers, supervision, and the health and safety representative. To make orientation successful, supervisors should follow some simple steps.

- Talk to new hires. Put them at ease. Find out how much they know already. Explain why their job must be done right, how it relates to the rest of the operation, and what hazards may be involved.
- Explain assignments carefully to new workers. Tell them, show them, ask questions to make sure they understand. Cover one step at a time. Make key operations and safety points clear. Be patient and go slowly.
- Test the new hire's performance. Watch while the job is being done. Commend good work. When necessary, show how the job can be done more safely and efficiently.
- Let new workers continue on their own. Tell them who to contact for help and encourage them to get help when needed.
- Follow up. Check on work frequently at first. Look for any bad habits, unnecessary motions, or unsafe acts that need correcting. Ease off when you're convinced that workers are doing the job safely and correctly.









Jobsite Safety Talks

Jobsite talks can help prevent accidents and injuries by promoting hazard awareness in the workplace. Supervisors should present safety talks on a regular basis and follow these guidelines.

- Before presenting a prepared talk, look it over. Instead of reading the talk to your crew, use your own words. Personnel will more likely accept your natural manner than a formal presentation.
- Choose subjects that are directly related to site conditions or the company's health and safety policy and program.
- Encourage participation. Get the crew to talk about close calls and hazards. Solutions to these problems can become the subject of future talks.
- Make a note of any hazards the crew may mention as well as any suggestions for improving health and safety. Subjects requiring management attention should be referred to management.
- Always follow up. Tell the crew what has been done to correct problems and improve conditions on the job.

Safety Tips and **Safety Talks** are available from the Construction Safety Association of Ontario. Check them out at www.csao.org.

2 EMERGENCY PROCEDURES

Emergency Procedures	
1	 <p>TAKE COMMAND Assign the following duties to specific personnel.</p>
2	 <p>PROVIDE PROTECTION Protect the accident scene from continuing or further hazards - for instance, traffic, operating machinery, fire or live wires.</p>
3	 <p>GIVE FIRST AID Give first aid to the injured as soon as possible. Information on basic first aid is included in this manual.</p>
4	 <p>CALL AN AMBULANCE Call an ambulance and any other emergency services required. In some locales, dialing 911 puts you in touch with all emergency services.</p>
5	 <p>GUIDE THE AMBULANCE Meet and direct the ambulance to the accident scene.</p>
6	 <p>GET NAME OF HOSPITAL For follow-up, find out where the injured is being taken.</p>
7	 <p>ADVISE MANAGEMENT Inform senior management. They can then contact relatives, notify authorities, and start procedures for reporting and investigating the accident.</p>
8	 <p>ISOLATE THE ACCIDENT SCENE Barricade, rope off or post a guard at the scene to make sure that nothing is moved or changed until authorities have completed their investigation.</p>

For more information refer to

- **Emergency Response Planning** (B030), booklet available from CSAO
- **Emergency Response** (P103), poster available from CSAO
- rescue procedures for fall arrest (see the Personal Fall Protection chapter in this manual).

Health

3 WHMIS

Frequently construction trades are required to work with new hazardous materials or previously installed hazardous materials requiring repair, maintenance, or removal. Some materials used for many years and thought to be harmless are now known to be hazardous.

Proper handling requires careful planning, training, and use of personal protective equipment or controls.

Some hazardous materials common in construction are

- compressed gas (acetylene, nitrogen, oxygen)
- flammable and combustible materials (solvents)
- oxidizing materials (epoxy hardeners)
- solvents, coatings, and sealers
- asbestos and silica
- acids and alkalis.

Right to Know

The **Workplace Hazardous Materials Information System (WHMIS)** gives everyone the right to know about the hazards of materials they work with and provides the means to find out that information. It does this through

- labels
- material safety data sheets
- worker training and education.

All employers are required by law to provide WHMIS training for specific controlled products the worker will be working with or near. Training should be provided as new products are introduced – with a general updating on new products at least annually.

Controlled products under WHMIS include six classes, identified by symbols (Figure 6).

The requirements for supplier and workplace labels are shown in Figure 7.









CLASS SYMBOL	EXAMPLE
Class A: Compressed Gas	 oxygen
Class B: Flammable and Combustible Material	 acetone
Class C: Oxidizing Material	 chromic acid
Class D: Poisonous and Infectious material	
1. Materials causing immediate and serious toxic effects	 ammonia
2. Materials causing other toxic effects	 asbestos
3. Biohazardous Infectious Material	 contaminated blood products
Class E: Corrosive Material	 hydrochloric acid sodium hydroxide
Class F: Dangerously Reactive Material	 acetylene

Figure 6

Supplier labels are required on controlled products with a volume of more than 100 millilitres and must include

- product identifier
- appropriate hazard symbol(s)
- risk phrases (such as “dangerous if inhaled”)
- precautions (such as “wear rubber gloves”)
- first aid measures
- supplier identifier
- statement that a material safety data sheet (MSDS) is available for the product.

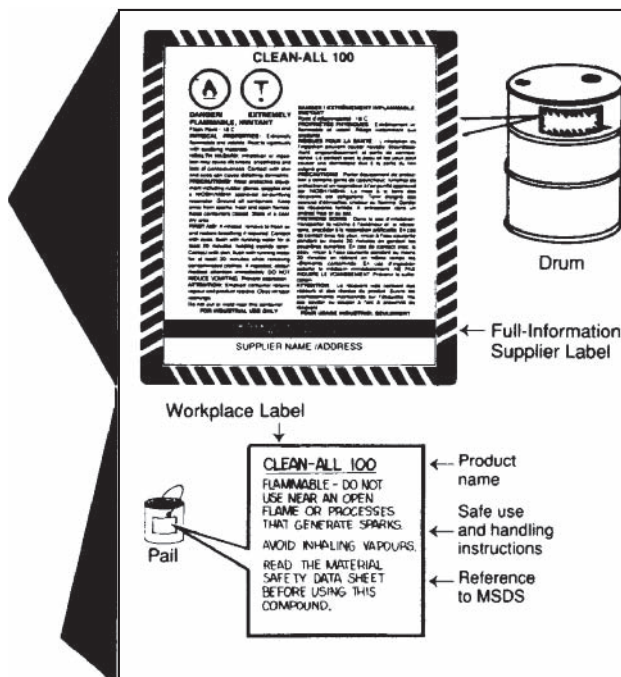


Figure 7

Workplace labels are required when controlled products are produced onsite or have been transferred from a supplier-labelled container to a different container.

Workplace labels must include

- product identifier
- safe handling instructions
- statement that an MSDS is available for the product.

If details on the ingredients, health effects, handling, and other aspects of a hazardous product are not available from suppliers or employers, call the Construction Safety Association of Ontario at 1-800-781-2726 and provide the following information.

- Product name (for example, Solvex 100)
- Manufacturer's name and place of manufacture (for example, ABC Chemical, Montreal, Quebec)
- What is the product being used for? (for example, to clean parts)
- How is it being used? (for example, sprayed on)
- Is it being mixed with something else?
- Is it being heated?
- In what area is it being used? (for example, outdoors or in a holding tank)
- What does the label say?
- How can information be conveyed to you?

Designated Substances

“Designated substances” are substances that have been targeted for special regulation by the Ministry of Labour. Generally these substances are well-known toxic materials which present serious risk of illness.

Designated substances encountered in construction include asbestos, lead, coal tar products, and silica. If any designated substances are present where construction, maintenance, or renovation is planned, the parties involved must be notified and informed.

The *Occupational Health and Safety Act* requires that owners notify contractors of the presence of any designated substance. Contractors also have a responsibility to advise subcontractors. This notification must take place before binding contracts are arranged.

For more information on designated substances, contact the Ministry of Labour.

4 FIRST AID

According to St. John Ambulance, “First aid is emergency help given to an injured or suddenly ill person using readily available materials.” It may be as simple as cleaning and bandaging a minor cut on a worker’s finger, or it can be complicated, such as providing care for a worker who has been struck by a piece of moving equipment.

The objectives of first aid are the same, regardless of the situation. They are to

- preserve life
- prevent the injury or illness from becoming worse
- promote recovery.

The First Aid Requirements Regulation (Regulation 1101 under the *Workplace Safety and Insurance Act*) details the obligations of employers regarding first aid equipment, facilities, trained personnel, and first aid procedures in all workplaces. The Act authorizes the WSIB to penalize employers who do not comply with these requirements. Here is a brief outline.

Equipment

Employers must provide and maintain a first aid station in the workplace. Pick a location for the kit that it is accessible at all times. Companies who use service vehicles should ensure that first aid kits are provided for each vehicle. As well, provide a first aid kit when workers are operating heavy construction and maintenance equipment at a distance from the first aid station. The contents will vary according to the number of employees regularly employed in that workplace. Regulation 1101 provides the details of the contents. Inspect each kit at least quarterly, then sign and date the inspection card.

Facilities

In a workplace with few employees, the first aid station may be as simple as a first aid kit placed



First aid station

in an accessible area. Large companies (over 200 employees) are required to have a first aid room. On construction projects, it’s the responsibility of the general contractor to provide the first aid station. It should be located in the site office. On a large project, set up additional first aid stations to ensure timely access to treatment. In all cases, the regulation requires you to post the WSIB Form 82 (“In Case of Injury at Work” poster), a first aid kit inspection card, and the valid first aid certificates of the first aid providers in the workplace.

Trained personnel

Employers must ensure that first aid is provided by trained and knowledgeable workers. Regulation 1101 specifies training either to the St. John Ambulance Emergency or Standard First Aid levels (or equivalent) depending on the number of workers in the workplace.

Emergency-level first aid training generally includes the following mandatory topics

- Emergency Scene Management
- Shock, Unconsciousness, and Fainting
- Choking—Adult
- Severe Bleeding
- One Rescuer CPR—Adult

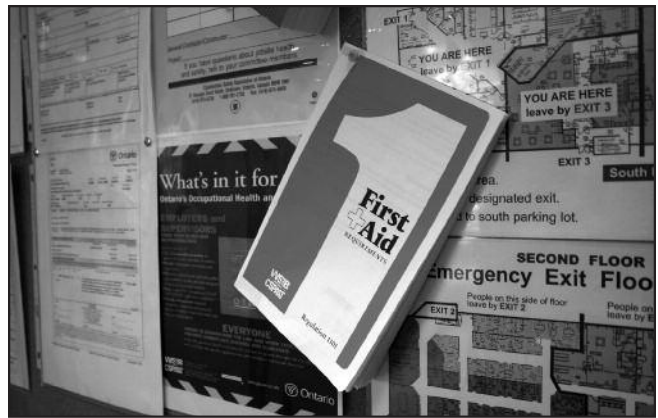
Standard-level first aid training is a more extensive program that generally includes the

five mandatory topics from emergency first aid, as well as elective topics. Some elective topics suitable for first aid providers are

- Fractures
- Head and Spinal Injuries
- Joint Injuries
- Chest Injuries
- Hand injuries
- Eye injuries
- Multiple injury management
- Pelvic, abdominal, and crush injuries
- Burns
- Poisoning
- Medical conditions (diabetes, epilepsy, convulsions, and allergies)
- Environmental illnesses and injuries (exposure to heat or cold)
- Artificial respiration – Adult
- Automated External Defibrillator (additional instruction time must be added to the course to accommodate this component and a separate certification card must be issued for AED certification)

Since procedures may change from time to time, it is important that training be kept up to date. Recertification is usually required every three years (check with your training organization for details).

In a workplace with five or fewer workers, the employer must ensure that a worker trained in at least St. John Ambulance Emergency First Aid (or equivalent) is available to provide first aid. This also applies when a crew of two to five workers is working away from their company facility, such as a painting crew working in a vacant office. When six or more workers are employed in a workplace, the regulation requires St. John Ambulance Standard First Aid



The First Aid Requirements Regulation

(or equivalent) training for the first aid provider. Additional workers should be trained in the event of the designated provider's absence.

First Aid Procedures

To ensure that an injured or ill worker receives appropriate and timely first aid treatment, an employer should have a written first aid procedure as part of their Health and Safety Program. The procedure should cover

- mandatory reporting and recording requirements
- provision of first aid kits
- availability of trained first aid providers and training recertification
- transportation to medical treatment
- document posting requirements.

The First Aid Requirements Regulation requires that each first aid kit contain a current edition of the St. John Ambulance First Aid Manual. The manual contains details of first aid treatment for a worker who is injured or who suddenly becomes ill. The first aid provider can use it as a reference for specific protocols.

For details on signs, symptoms, and treatment of illnesses and injuries related to heat or cold exposure, refer to the chapters on Heat Stress and Cold Stress in this manual.

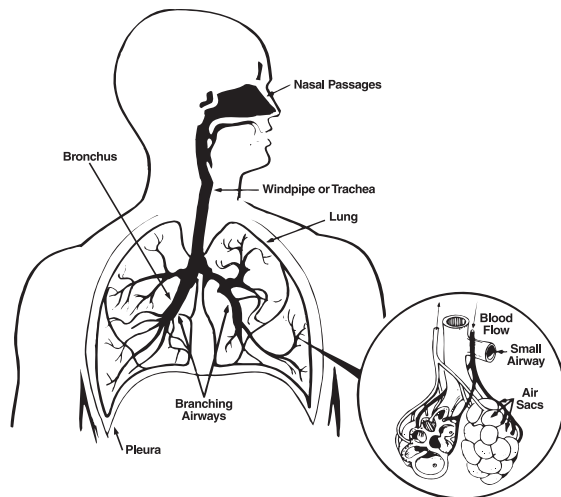
5 OCCUPATIONAL HEALTH

Routes of entry

Hazardous materials in the workplace may cause disease in the body at four main sites:

- where they enter the body—entry routes such as the lungs, skin, and intestines
- in the blood that carries the hazardous materials throughout the body
- in the central nervous system
- in the organs which have the ability to remove toxic agents from the body:
i.e., the liver, kidneys, and bladder (exit routes).

This section briefly describes four routes of entry—*inhalation, absorption, ingestion, and injection*—and some of the workplace hazards and diseases commonly associated with them.



THE RESPIRATORY SYSTEM

Inhalation

The body's respiratory—or breathing—system is one of the most common routes of entry for a toxic substance. The substance may cause damage to the system itself or it can pass through the lungs to other parts of the body.

The main function of the respiratory system is to absorb oxygen from the air and pass it on to the blood. It also removes carbon dioxide—the waste gas produced by the body's processes—from the blood and releases it in exhaled air.

Air reaches the lungs through a branching system of tubes, starting with the trachea, or windpipe, which divides to form two bronchi, one to each lung. Each bronchus, in turn, branches into many smaller divisions, finally ending in a small cluster of tiny air sacs which are known as alveoli. The oxygen and carbon dioxide exchange takes place through a very thin membrane surrounding these air sacs.

The lung is covered by a delicate lining known as the pleura. (Mesothelioma, one of the cancers caused by asbestos, is a cancer of the pleura.)

Cancer

It's not well understood exactly how a chemical produces cancer. Some **carcinogens** (cancer-causing substances) are thought to interact with the genetic material of the cell; others may interact with the immune system; and still others are thought to act with other agents, but not initiate cancer themselves. Whatever the mechanism, the effect is very often delayed, sometimes up to 30 years.

Defining a chemical as carcinogenic usually involves animal studies as a first step. If the substance causes cancer in animals, particularly those that have biological systems similar to humans, it is classed as a suspected carcinogen. Two examples are silica and refractory ceramic fibres which cause lung cancer. Some chemicals have also been shown to be cancer-causing through industrial experience. These include asbestos (cancer of the larynx, lung, and abdomen), vinyl chloride (liver cancer), coal tar pitch (skin cancer), chromium (lung cancer), and benzidine (bladder cancer). All chemicals which have been classified as carcinogens should be handled with extra care.

Asbestos

Inhaling asbestos dust has been shown to cause the following diseases:

- asbestosis
- lung cancer
- mesothelioma (cancer of the lining of the chest and/or abdomen).

Asbestosis is a disease of the lungs caused by scar tissue forming around very small asbestos fibres deposited deep in the lungs. As the amount of scar tissue increases, the ability of the lungs to expand and contract decreases, causing shortness of breath and a heavier workload on the heart. Ultimately, asbestosis can be fatal.

Lung cancer appears quite frequently in people exposed to asbestos dust. While science and medicine have not yet been able to explain precisely why or how asbestos causes lung cancer to develop, it is clear that exposure to asbestos dust can increase the risk of contracting this disease. Studies of asbestos workers have shown that the risk is roughly five times greater than for people who are not exposed to asbestos.

Cigarette smoking, another cause of lung cancer, multiplies this risk. Research has shown that the risk of developing cancer is at least fifty times higher for asbestos workers who smoke than for workers who neither smoke nor work with asbestos.

Mesothelioma is a relatively rare cancer of the lining of the chest and/or abdomen. While this disease is seldom observed in the general population, it appears frequently in groups exposed to asbestos.

Other illnesses—There is also some evidence of an increased risk of cancer of the stomach, rectum, and larynx. However, the link between asbestos exposure and the development of these illnesses is not as clear as with lung cancer or mesothelioma.

The diseases described above do not respond well to current medical treatment and, as a result, are often fatal.

See the chapter on Asbestos in this manual.

How hazardous materials evade the lung’s defences

The airways of the respiratory system have developed an elaborate system of defences which trap all but the smallest dust particles. This system consists of hairs in the nose and mucus in the trachea or bronchi. The mucus is produced continuously by special cells in the walls of the larger airways. It is moved upward and to the back of the throat by the whipping action of cilia—tiny, hair-like projections on the cells of the trachea and bronchi.

Large dust particles are trapped in the mucus and are either swallowed or spit out. Particles smaller than 0.5 microns (1 inch has 25,400 microns) may remain airborne and are exhaled. The most dangerous size of dust particles is 0.5-7.0 microns. Much too small to be seen with the naked eye, they can evade the defence system and reach the lungs. Once in the lungs, these tiny particles of dust may cause extensive scarring of the delicate air sacs. This scarring starts the disease process which produces severe shortness of breath.

Most dust particles are too large to pass through the walls of the alveoli, but gases, vapours, mists, and fumes can all enter the bloodstream through the lungs. In addition, welding fumes or truck exhausts can stimulate the lung’s defences to produce large amounts of phlegm, causing the condition known as chronic bronchitis. These same substances can destroy the delicate air sacs of the lungs, causing emphysema.

The lungs are the prime target for occupational carcinogens because the lungs

- are in intimate contact with workplace air pollutants
- have such a large surface area (100-140 m²).

Asphyxiants

Chemicals that interfere with the transfer of oxygen to the tissues are called asphyxiants. The exposed individual literally suffocates because the bloodstream cannot supply enough oxygen for life.

There are two main classes of asphyxiants—simple and chemical. **Simple asphyxiants** displace oxygen in the air, thereby leaving less or none for breathing. **Chemical asphyxiants** cause the same effect by interfering with the body’s ability to take up, transport, or use oxygen.

Simple asphyxiants are a major hazard in confined spaces, where breathable air can be displaced by gas from sewage, for instance.

When the normal oxygen level of 21% drops to 16%, breathing and other problems begin, such as lightheadedness, buzzing in the ears, and rapid heartbeat. Simple asphyxiants in construction include argon, propane, and methane. These chemicals usually have no other toxic properties.

Carbon monoxide is one example of a chemical asphyxiant. It combines with the oxygen-carrying compound in the blood and reduces its ability to pick up “new” oxygen. Hydrogen sulphide, on the other hand, interferes with the chemical pathways which transfer the oxygen, while hydrogen cyanide paralyzes the respiratory centre of the brain.

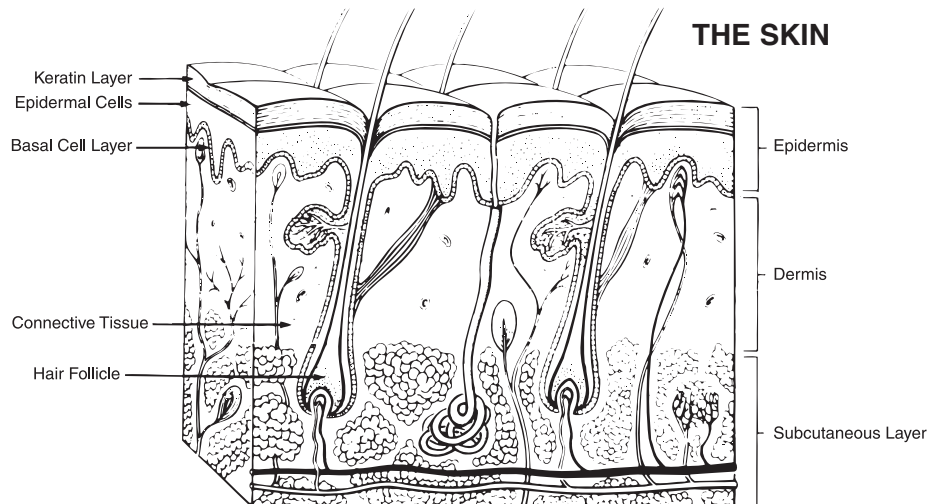
Skin absorption

Absorption through the skin is another common form of entry for toxic substances (e.g., organic solvents).The skin is the largest organ of the body, with a surface area of 1 to 2 m². Some chemicals can penetrate through the skin, reach the bloodstream, and get to other parts of the body where they can cause harm. Toluene and Cellosolve are examples of chemicals which are absorbed through the skin. Mineral spirits and other solvents used in the manufacturing of paint can easily penetrate the skin.

The skin

The skin protects the internal organs of the body from the outside environment. Its outer layer is composed of hardened, dead cells which make the skin resistant to daily wear and tear. Sweat glands cool the body when the environment is hot. Sebaceous glands produce oils which repel water. A network of small blood vessels, or capillaries, plays a key role in controlling body temperature. These capillaries open when it is hot, radiating heat outward into the air, and constrict when it is cold, conserving heat in the body. The skin also has a protective layer of oils and proteins which helps to prevent injury or penetration by harmful substances.

A substance may be absorbed and travel to another part of the body, or it may cause damage at the point of entry (the skin), and start the disease process. Such substances are usually identified in an MSDS with a notation “skin” along with their exposure limits, indicating that the exposure can occur through the skin, mucous membranes, or eyes, or may damage the skin itself.



**TABLE 1
MAJOR DERMATITIS HAZARDS IN CONSTRUCTION**

MATERIAL	TYPE	OCCUPATION/ACTIVITY	CONTROLS
Wet Concrete	Allergic/Corrosive	- Concrete Workers	- Rubber boots, rain pants, rubber gloves if necessary.
Epoxy Materials	Allergic/Defatting (solvents may aggravate allergy)	- Cement Finishers - Seamless Floor Installers - Painters - Tile/Terrazzo Installers	- Barrier creams - Gloves resistant to specific solvents (see Glove Selection Chart in this manual) - Good personal hygiene
Coal Tar	Allergic	- Roofers - Waterproofers	- Change work clothing daily if doing dusty work - Barrier creams usually work well - Good personal hygiene
Solvents/Degreasers	Defatting	- Mechanics - Painters - Service Trades - Millwrights	- Appropriate gloves (see Glove Selection Chart in this manual) - Minimize skin contact - Good personal hygiene
Cleaners	Corrosive/Defatting	- Labourers - Service Trades	- Usually rubber gloves, boots and maybe rain pants - Good personal hygiene

Skin irritation

Dermatitis is an inflammation of the skin which can be caused by hundreds of workplaces substances like solvents (paints), epoxy resins, acids, caustic substances, and metals. Dermatitis appears as redness, itchiness, or scaling of the skin. There are two types of dermatitis:

- primary irritation dermatitis (contact dermatitis), and
- sensitization dermatitis (allergic dermatitis).

Major dermatitis hazards in construction are listed in Table 1.

Contact dermatitis is caused by friction, heat or cold, acids, alkalis, irritant gases, and vapours. Skin in contact with the chemical turns red, becomes itchy, and may develop eczema (inflammation, scaling, and collection of fluid droplets under the skin's surface). Typical hazards in construction include caustics, acids, many chlorinated solvents, wet concrete, chromic acid, and calcium hydroxide.

Allergic contact dermatitis, on the other hand, is the result of an allergic reaction to a given substance. Sensitization may be the result of prolonged or repeated contact and becomes established usually within 10 to 30 days. The process could also take years.

Once sensitized, even a minute exposure can produce a severe reaction. Substances like organic solvents (paints), chromic acid, and epoxy resins can produce both primary and contact dermatitis. Sensitizers include epoxy materials (especially the hardener), nickel, and chromium.

Certain agents such as coal tar and creosote can have a strong sensitizing effect when combined with exposure to sunlight—they are known as photosensitizers.

Solvents

Keratin solvents: These injure or dissolve the outer layer of the skin producing dry, cracked skin. All the alkalis such as ammonium hydroxide, sodium hydroxide, and calcium chloride are keratin solvents.

Fat and oil solvents: These remove the surface oils of the skin so that it can no longer hold water efficiently. Dry, cracked skin results. Organic solvents such as toluene and xylene will cause this condition.

Keratin stimulants: On contact these primary irritants cause a change in the skin so that unusual growth appears, as with exposure to coal tar pitch and arsenic.

Some hazardous materials used in the workplace have been linked with skin cancer. A number of them are listed in Table 2.

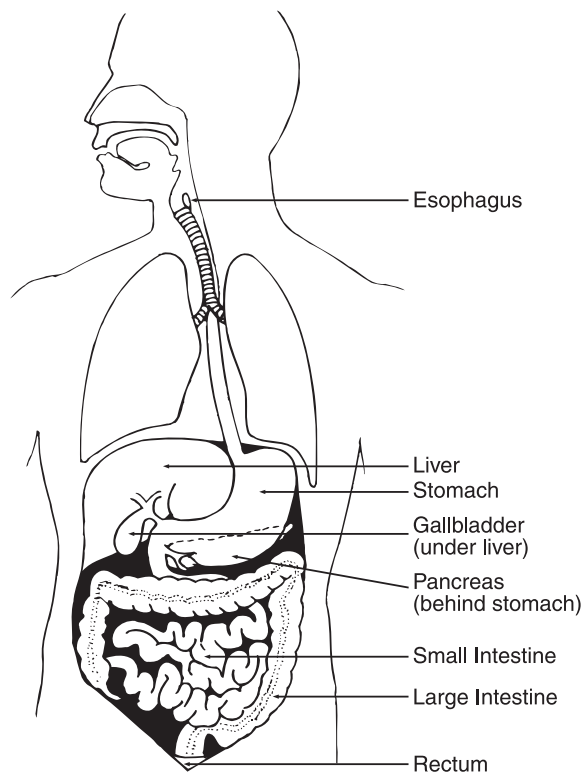
TABLE 2

<u>Some Suspected Workplace Causes of Skin Cancer</u>		
Pitch	Arsenic	Ultraviolet Light
Asphalt	Tar	X-Rays
Benzo(a)pyrene	Creosote	Anthracene
Shale Oil	Cutting Oils	Soot

Ingestion

A third major route of entry for toxic substances is through the mouth and digestive tract. Toxic materials may reach the stomach when food or drink is consumed, when cigarettes are smoked in a dusty work area, when clean lunchrooms are not provided, when workers fail to wash their hands before eating or smoking, or when food is left unwrapped in a dusty place. Lead dust, for example, is easily ingested in this way and can have serious health effects. Once swallowed, the substances enter the digestive tract and may enter the bloodstream.

The digestive tract is a continuous tube that extends from the mouth to the rectum. The organs of the digestive system provide the means of ingestion, digestion, and absorption of food. Almost all digestion and absorption of food and water take place in the small intestine. The large intestine generally absorbs vitamins and salts.



THE DIGESTIVE SYSTEM

Once swallowed, the toxic substances enter the digestive tract, where they may enter the bloodstream and move on to the liver. The liver and kidneys try to remove the poisons and make the substances less harmful to the body, but they are not always successful.

Injection

In rare cases the chemical may enter the body by injection. Skin can be punctured by paint from a high-pressure spray gun or oil from a high-pressure hydraulic hose. This is very serious and requires prompt medical attention. Chemicals in the paint or oil can damage the immediate area and be transported by the blood to a target organ. Chemicals can also be injected into the body by means of puncture wounds from nails or staples, for example.

Hazardous substances in the body

The circulatory system

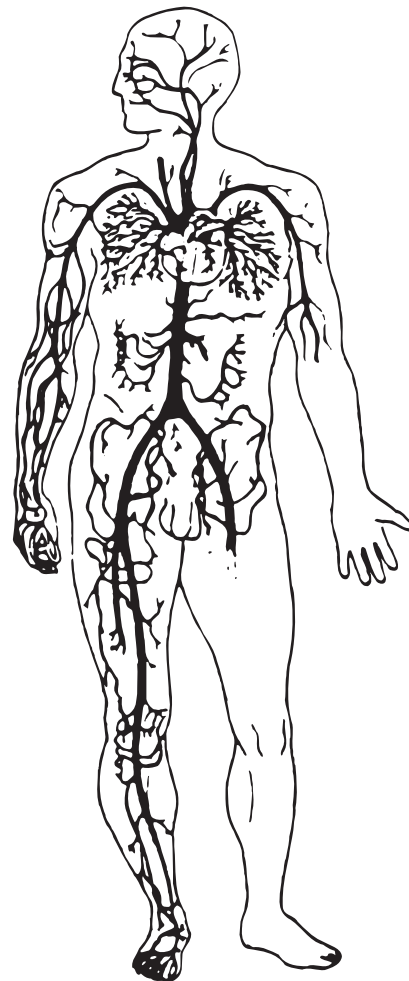
The circulatory system is not usually in direct contact with hazardous materials. Once in the bloodstream, however, harmful substances can be transported to any part of the body.

The centre of the circulatory system is the heart. It pumps blood outward through a vast network of blood vessels which branch like a tree, becoming smaller and smaller as they go. The vessels branch so extensively that no cell is more than a few millimeters from a blood vessel or capillary.

Table 3

Some Substances Which May Cause Anemia

Arsine Gas	Cadmium
Selenium	Copper
Lead	Gallium
Stibine	Mercury Compounds
Beryllium	Benzene
	Toluene



Hazards to the circulatory system

Food and oxygen reach every cell in the body through capillaries, but so do toxic substances from the workplace. Oxygen is carried by a protein called hemoglobin, which is contained in the red blood cells. Oxygen binds strongly to hemoglobin, but unfortunately, so does carbon monoxide, a common workplace hazard produced by combustion engines in trucks, machinery, etc. In fact, carbon monoxide binds or attaches to hemoglobin about 200-300 times more readily than oxygen.

In high concentration, carbon monoxide can kill because it overloads the hemoglobin in the red cells and replaces the oxygen which the body needs to survive. But even low levels of repeated carbon monoxide exposure may have serious effects on the heart and the central nervous system.

Many toxic substances attack the blood cells directly. The body forms blood cells continually in the marrow cavity inside the bones. Hazardous materials like benzene can interfere with this formative process and cause anemia, a shortage of red blood cells. Table 3 lists some of the materials which may cause anemia.

The liver

The liver is the chemical factory of the body. The cells which make up the liver contain enzymes which can convert certain toxic substances into forms that are more easily handled by the body. But the liver itself may be damaged if it is overwhelmed by toxic substances.

The liver may become inflamed, producing the condition known as **hepatitis**. This disease may be caused by a virus or by chemicals like alcohol, carbon tetrachloride, and other chlorinated hydrocarbons. Repeated bouts of hepatitis may lead to liver scarring and a disease called **cirrhosis** of the liver. Generally speaking, it means that there are not enough normal liver cells remaining to detoxify body chemicals.

Overexposure to chemicals like acrylonitrile, benzene, carbon tetrachloride, DDT, chloroform, phenol, styrene, tetrachloroethane, and tetrachloroethylene may also cause liver damage. Vinyl chloride, a substance used in the production of plastics, has been linked to a rare and deadly form of liver cancer called angiosarcoma. Table 4 lists some substances that may cause liver damage.

Table 4

Some Substances Suspected of Causing Liver Damage		
Antimony	Acrylonitrile	Ethylidene Dichloride
Arsine	Benzene	Hydrazine
Beryllium	Carbon Tetrabromide	Methyl Alcohol
Bismuth	Carbon Tetrachloride	Methyl Chloride
Cadmium	Chlorinated Benzenes	Methylene Dianiline
Copper	Chloroform	Naphthalene
Indium	Cresol	Phenol
Manganese	DDT	Pyridine
Nickel	Dimethyl Sulfate	Styrene
Phosphorus	Dioxane	Tetrachloroethane
Selenium	Epichlorohydrin	Tetrachloroethylene
	Ethyl Alcohol	Toluene
	Ethylene Chlorohydrin	Trichloroethane
		Trichloroethylene

The kidneys and bladder

The kidneys act as a filter for substances in the blood. Each kidney contains over a million small filters. These filters clean the blood, removing a number of impurities which they deposit in the urine. The urine then passes to little tubes which monitor the levels of acid and the amount of water in the body, and keep them balanced. From these tubes, the urine moves to the bladder, which stores it until it is released from the body.

Since the kidneys act as filters, they can be seriously injured by toxic substances passing through the body. Kidney disorders may result in high or low blood pressure, which in turn may cause heart strain or heart failure. Kidney malfunction may also upset the body's delicate chemical balance, resulting in further harm to the body.

Just as the lungs are vulnerable to hazardous materials because they are a major route of entry, the kidneys and bladder are vulnerable because they are a major route of exit.

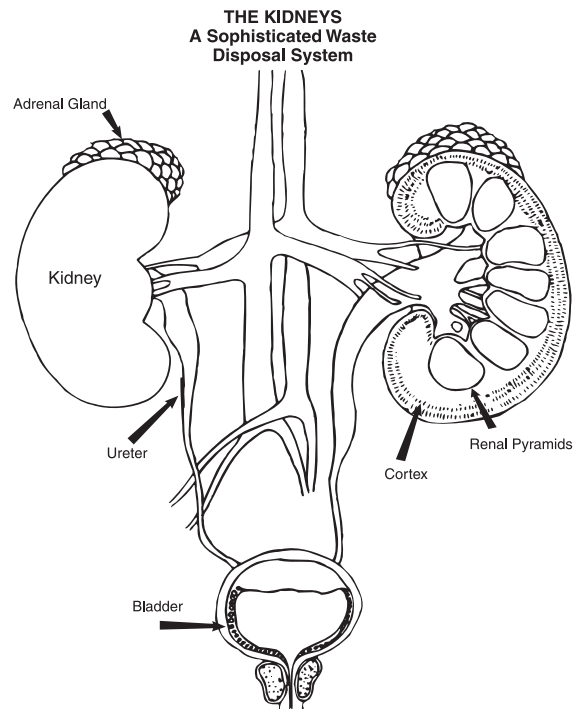


Table 5 shows some of the suspected causes of kidney damage.

Table 5

Suspected of Causing Kidney Damage	
Lead	Naphthalene
Mercury	Carbon Tetrachloride
Cadmium	Tetrachloroethane
Chromates	Carbon Monoxide
Copper	Gasoline Vapours
Uranium	Turpentine
Beryllium	Bismuth
Arsenic	Oxalic Acid
Arsine	Intense Heat
Sodium Fluoride	Vibration
Iodine	High Voltage Shocks
Carbon Disulfide	Blood Loss

The nervous system

To stay alive, we must breathe continuously, our heart must pump constantly, and all the other organs must function. We also think and respond to emotions and sensations. All these functions performed by the mind and body are controlled by the nervous system.

Table 6

Some Chemicals That May Affect the Nervous System			
Depression of Central Nervous System	Brain Poisoning	Brain Damage by Oxygen Deprivation	Nerve Function Disorders
Acetates Alcohols Brominated chemicals Chlorinated chemicals Ethers Ketones	Carbon disulfide Hydrogen cyanide Hydrogen sulfide Stibine Arsine	Asphyxiating gases Carbon monoxide	Organo-phosphate pesticides Organo-phosphate plasticizers Heavy Metals Mercury Lead Manganese Arsenic

The central nervous system is the control centre. The spinal cord connects the brain to the nervous system. Part of the nervous system reaches the outer areas and is called the peripheral nervous system.

Most injuries of the central nervous system are permanent, although damage to the peripheral nervous system can sometimes be reversed. Exposure to metals like lead and mercury may interfere with nerve impulses and result in tremors and loss of reflexes or feeling.

Central nervous system depression covers effects such as headache, lightheadedness, drowsiness, and unconsciousness. The organ affected is the brain and the result is depressed performance. Many solvents such as toluene, xylene, ether, and acetone produce this effect if the vapour concentration is high enough. Workers exposed to these chemicals in cleaning solvents, paints, thinners, and degreasers may have experienced these effects.

The brain needs a constant supply of oxygen. Some toxic chemicals interfere with the functioning of the central nervous system and disrupt the oxygen supply. The first warning signs are dizziness and drowsiness. Warning signs should be heeded immediately and appropriate action taken. For example, you should immediately leave the area and seek medical assistance.

The operations of the nervous system are very complicated. It is a delicately balanced system and several chemicals can damage it, such as those shown in Table 6.

The reproductive system

Workplace hazards affect the worker, but the problem reaches into the worker's home as well.

The reproductive organs—the testes in men and the ovaries in women—produce the cells that allow us to reproduce. Any damage to these cells can have disastrous consequences. Deformities in children may result or the developing embryo may be so severely damaged that it is unable to survive and is miscarried.

Some chemicals cause miscarriages or birth defects by attacking the genetic material of cells or the systems which control its functions. Similar damage may also be involved in cancer—cancer-causing substances are often the cause of birth defects and miscarriages.

Factors	<i>Reduced fertility</i>	<i>Miscarriages</i>	<i>Chromosomal damage</i>	<i>Malformations</i>	<i>Sperm damage</i>
Anaesthetic gases	♂	♂♀		♀	
Benzene	♂		♂♀		
Mercury		♀		♀	
Epichlorohydrin			♂♀		
Ethylene dibromide	♂				
Ethylene oxide		♀	♂♀		
Glutaraldehyde		♀			
Ionizing radiation	♀	♀	♂♀	♀	
Chloroprene	♂	♂			♂
Lead	♂♀	♀			♂
Organic solvents	♂	♀	♀	♀	
Carbon disulphide	♂	♀			
Vinyl chloride		♂	♂		

Legend:

♂ = Male exposure

♀ = Female exposure

Source: Finland's Institute for Occupational Health, Helsinki.

Effects of hazardous substances

The effects of exposure to workplace safety hazards are sometimes immediate, painful, and obviously damaging, but it is not always easy to observe when and how the body's cells are attacked by hazardous materials in the workplace. Many of the most serious diseases do not occur until 10 to 30 years after exposure.

Latency of workplace disease

Latency refers to the time lag between exposure to a hazardous material and the eventual development of a disease. The latency period does not refer to the total duration of exposure to a substance, but to the time that has elapsed since the first exposure. For many occupational hazards, the latency period is from ten to twenty years. It may even be as long as thirty or forty years.

Latency has a number of important implications for the worker. An individual exposed to a highly dangerous substance may feel no ill effects at the time of exposure. The effects may only show up many years later. For instance, exposure to ionizing radiation or asbestos causes very little in the way of symptoms at the time of actual exposure, but the long-term effects can be deadly.

Past scientific studies have often failed to address the problem of latency in evaluating the incidence of disease (such as asbestosis). In order to develop a clear picture of diseases which appear many years after exposure, researchers must study not only the current workforce (including many workers who have worked in a particular environment for less than twenty years), but also those workers who had exposure in the past.

Finally, a workplace free of disease is not necessarily a workplace free of hazards. The diseases of today generally reflect the working conditions of several decades ago. Similarly, the workplace hazards of today may produce the health problems of the future.

Acute and chronic effects of workplace hazards

Workplace hazards may have both immediate and long-term effects on the body. These are termed acute and chronic effects. The sudden collapse of a worker who has been exposed to massive doses of carbon monoxide, or the headaches of a backhoe operator working in a poorly ventilated cab, are examples of acute effects.

The acute effects of toxic substances occur immediately or very soon after the worker's exposure, and are generally caused by high levels of exposure. They may cause death, but are often treatable if caught quickly. Sudden and dramatic, they result from the direct action of the hazardous material on the cells of the body.

Often more serious, however, are the chronic effects of toxic substances. Chronic effects become apparent only after many years. By and large, they are not treatable. They often result from the body's attempts to repair itself or to compensate for the acute effects of a substance. For example, cancer is a chronic effect, as is the lung scarring caused by silica dust or the hearing damage caused by excessive noise. Chronic disease becomes evident only after severe damage has occurred.

The acute effects of hazardous material are usually very different from the chronic effects. Table 7 illustrates the difference between the acute and chronic effects of some of the hazards discussed earlier.

Table 7

Acute and Chronic Effects of Some Common Workplace Hazards		
	Acute	Chronic
Acid Mists	Irritation of the eyes and throat, watering of the eyes, cough, sore throat, chest pain	Chronic bronchitis and emphysema
Asbestos	Mild respiratory irritation, cough, sneezing	Asbestosis; cancer of the lung, pleura, larynx, stomach, and intestines
Carbon Monoxide	Drowsiness, headache, confusion; in very high amounts, unconsciousness and death	May contribute to heart attacks
Dust (containing silica)	Cough, irritation, bronchitis, asthma	Silicosis, cancer, bronchitis
Noise	Temporary threshold shift, tinnitus, pain	Noise-induced hearing loss, tinnitus
Trichloroethylene	Lightheadedness, euphoria, "drunken" feeling, numbness	Liver and kidney damage; possibly liver cancer
Vibration	Tingling and stiffness in the joints	Arthritis, tendonitis

Exposure limits have been developed for various hazardous materials to protect workers, but they should not be treated as a fine line between safe and unsafe workplaces. Not all individuals react in the same manner to the same amount of a harmful material. The levels of workers' exposures should be reduced to the lowest practical level achievable. Efforts to reduce workers' exposures should start at half the exposure limit. This is known as the "action level."

Factors influencing toxic effect

Factors related to the substance

a) Chemical composition

Different chemicals produce different effects, but changes in composition may influence the toxic effect. For example, pressure-treated wood presents very little problem when dry. However, when the wood is burned the preservative decomposes, producing more toxic chemicals.

In some instances exposure to more than one chemical may change the toxic effect. For example, a person who works with solvents and then has a drink after work will get drunk faster and may have an increased risk of liver damage than from either factor alone.

b) Physical properties

With respiratory hazards, the two main concerns are particle size and vapour pressure.

Particles greater than 10 micrometers in diameter are removed from inhaled air in the nose and upper respiratory

system. As particle size decreases, the system's ability to remove particles also decreases until it is unable to filter out the substance.

Vapour pressure measures the potential of a liquid to vaporize. The higher the vapour pressure, the greater the hazard. If, for example, two solvents of equal toxicity are available for use, the one with the lower vapour pressure will present less of a vapour hazard and will therefore be the safer choice.

c) Solubility in body fluids

Certain chemicals are more soluble in body fluids than others. Chemicals termed lipid soluble are soluble in cell membranes. They can very easily penetrate the body and are more mobile once inside. By being lipid soluble they may also remain longer in the body before being excreted. Organic solvents such as toluene, xylene, acetone, and methanol are considered lipid soluble.

Factors related to exposure situation

a) Dose

With most chemicals, the frequency and severity of toxic effect is directly related to **how much** of the hazard the individual is exposed to and for **how long**. This is commonly referred to as the dose/effect or dose/response relationship. With ethyl alcohol, for example, there is no adverse effect if the dose is within the body's ability to control it. However, if the dose exceeds that capacity, the effect increases with the amount consumed.

By examining the past use of toxic materials in the workplace, by conducting animal studies, and by comparison with other substances, it is possible to assign "safe working levels" of exposure for many materials. The "threshold" is the level up to which no significant adverse effect is likely to occur in most people.

With some substances, mainly carcinogens, the safe working levels are difficult to define or may not exist. For this reason, exposures to known or suspected cancer-causing substances must be very closely controlled.

b) Co-factors

Most of the standards that are set for "safe working levels" are based upon exposure to one chemical at a time. In many cases this does not occur. For example, exposure to asbestos increases the risk of lung cancer five times, while smoking increases the risk 10 times. A smoker exposed to asbestos, however, is 50 times more likely to develop lung cancer than a person who does not smoke and is not exposed to asbestos. The concept of multiple exposures has not been extensively studied. As a result, exposures to complex mixtures should be kept as low as possible.

Factors related to the individual

Certain individuals are more susceptible to chemical exposure than others. These are some factors which may influence toxic effect.

a) Genetic status

Individual susceptibility may be explained by genetic make-up. It is suspected that the sites where toxic agents react is determined by genes that differ from person to person. This theory may help to explain why only some people exposed to a particular substance develop an illness while others do not.

b) Allergic status

In people allergic to certain substances, antibodies cause the body to overproduce its own chemical defences, leading to symptoms such as asthma and dermatitis.

For example, when a person is first exposed to epoxies or isocyanates a number of antibodies are produced. On subsequent exposure, the reaction is much more severe because of this store of antibodies. With repeated exposure, the allergic reaction can be triggered by smaller and smaller doses. This process is called "sensitization."

c) Presence of predisposing disease

Disease may make a person more susceptible to certain toxic agents as the body is already in a weakened condition.

For example, a person with a heart ailment such as angina may have a heart attack if exposed to levels of carbon monoxide which would have little effect on normal healthy people. Similarly, people who suffer from a lung ailment such as emphysema will have a much more severe reaction to lung irritants than a healthy person.

d) Age

Be aware that chemicals may have a greater effect on both older and younger workers.

6 HEAT STRESS

The Construction Safety Association of Ontario thanks the following for their help in developing this chapter:

- American Conference of Governmental Industrial Hygienists (ACGIH)
- Sarnia Regional Labour-Management Health and Safety Committee.

WHERE DOES HEAT STRESS OCCUR IN CONSTRUCTION?

Construction operations involving heavy physical work in hot, humid environments can put considerable heat stress on workers. Hot and humid conditions can occur either indoors or outdoors.

Indoors

- steel mills and foundries
- boiler rooms
- pulp and paper mills
- electrical utilities
- petrochemical plants
- smelters
- furnace operations
- oil and chemical refineries
- electrical vaults
- interior construction and renovation.

Outdoors

- roadbuilding
- homebuilding
- work on bridges
- trenching
- pouring and spreading tar or asphalt
- working on flat or shingle roofs
- excavation and grading.

Asbestos removal, work with hazardous wastes, and other operations that require workers to wear semi-permeable or impermeable protective clothing can contribute significantly to heat stress. Heat stress causes the body's core temperature to rise.

WHAT HAPPENS WHEN THE BODY'S CORE TEMPERATURE RISES?

The human body functions best within a narrow range of internal temperature. This "core" temperature varies from 36°C to 38°C. A construction worker performing heavy work in a hot environment builds up body heat. To get rid of excess heat and keep internal temperature below 38°C, the body uses two cooling mechanisms:

- 1) The heart rate increases to move blood—and heat—from heart, lungs, and other vital organs to the skin.
- 2) Sweating increases to help cool blood and body. Evaporation of sweat is the most important way the body gets rid of excess heat.

When the body's cooling mechanisms work well, core temperature drops or stabilizes at a safe level (around 37°C). But when too much sweat is lost through heavy labour or working under hot, humid conditions, the body

doesn't have enough water left to cool itself. The result is dehydration. Core temperature rises above 38°C. A series of heat-related illnesses, or heat stress disorders, can then develop.

HOW CAN WE RECOGNIZE HEAT STRESS DISORDERS?

Heat stress disorders range from minor discomforts to life-threatening conditions:

- heat rash
- heat cramps
- heat exhaustion
- heat stroke.

Heat rash

Heat rash—also known as prickly heat—is the most common problem in hot work environments. Symptoms include

- red blotches and extreme itchiness in areas persistently damp with sweat
- prickling sensation on the skin where sweating occurs.

Treatment—cool environment, cool shower, thorough drying. In most cases, heat rashes disappear a few days after heat exposure ceases. If the skin is not cleaned frequently enough the rash may become infected.

Heat cramps

Under extreme conditions, such as removing asbestos from hot water pipes for several hours in heavy protective gear, the body may lose salt through excessive sweating. Heat cramps can result. These are spasms in larger muscles—usually back, leg, and arm. Cramping creates hard painful lumps within the muscles.

Treatment—stretch and massage muscles; replace salt by drinking commercially available carbohydrate/electrolyte replacement fluids.

Heat exhaustion

Heat exhaustion occurs when the body can no longer keep blood flowing to supply vital organs and send blood to the skin to reduce body temperature at the same time. Signs and symptoms of heat exhaustion include

- weakness
- difficulty continuing work
- headache
- breathlessness
- nausea or vomiting
- feeling faint or actually fainting.

Workers fainting from heat exhaustion while operating machinery, vehicles, or equipment can injure themselves and others. Here's one example from an injury description filed with the Workplace Safety and Insurance Board:

High temperature and humidity in the building contributed to employee collapsing. When he fell, his head struck the concrete floor, causing him to receive stitches above the right eye.

Treatment—heat exhaustion casualties respond quickly to prompt first aid. If not treated promptly, however, heat exhaustion can lead to heat stroke—a medical emergency.

- Call 911.
- Help the casualty to cool off by
 - resting in a cool place
 - drinking cool water
 - removing unnecessary clothing
 - loosening clothing
 - showering or sponging with cool water.

It takes 30 minutes at least to cool the body down once a worker becomes overheated and suffers heat exhaustion.

Heat stroke

Heat stroke occurs when the body can no longer cool itself and body temperature rises to critical levels.

WARNING: Heat stroke requires immediate medical attention.

The following case is taken from a coroner's report.

On June 17, 1994, a rodworker was part of a crew installing rebar on a new bridge. During the lunch break, his co-workers observed him in the hot sun on the bulkhead of the bridge; the recorded temperature by Environment Canada for that day was 31°C with 51% humidity. Shortly thereafter the rodworker was found lying unconscious on the scaffold, apparently overcome by the intense heat. He was taken to a local hospital, then transferred to a Toronto hospital. However, despite aggressive treatment by numerous specialists, he died. Cause of death: heat stroke.

The primary signs and symptoms of heat stroke are

- confusion
- irrational behaviour
- loss of consciousness
- convulsions
- lack of sweating
- hot, dry skin
- abnormally high body temperature—for example, 41°C.

Treatment

For any worker showing signs or symptoms of heat stroke,

- Call 911.
- Provide immediate, aggressive, general cooling.
 - Immerse casualty in tub of cool water or
 - place in cool shower or
 - spray with cool water from a hose.
 - Wrap casualty in cool, wet sheets and fan rapidly.
- Transport casualty to hospital.
- Do not give anything by mouth to an unconscious casualty.

WARNING

- Heat stroke can be fatal even after first aid is administered. Anyone suspected of suffering from heat stroke should not be sent home or left unattended unless that action has been approved by a physician.
- If in doubt as to what type of heat-related disorder the worker is suffering from, call for medical assistance.

Heat Stress Disorders

	Cause	Symptoms	Treatment
Heat rash	Hot humid environment; plugged sweat glands.	Red bumpy rash with severe itching.	Change into dry clothes and avoid hot environments. Rinse skin with cool water.
Sunburn	Too much exposure to the sun.	Red, painful, or blistering and peeling skin.	If the skin blisters, seek medical aid. Use skin lotions (avoid topical anaesthetics) and work in the shade.
Heat cramps	Heavy sweating drains a person's body of salt, which cannot be replaced just by drinking water.	Painful cramps in arms, legs or stomach which occur suddenly at work or later at home. Heat cramps are serious because they can be a warning of other more dangerous heat-induced illnesses.	Move to a cool area; loosen clothing and drink cool salted water (1 tsp. salt per gallon of water) or commercial fluid replacement beverage. If the cramps are severe or don't go away, seek medical aid.
Fainting	Fluid loss and inadequate water intake.	Sudden fainting after at least two hours of work; cool moist skin; weak pulse	GET MEDICAL ATTENTION. Assess need for CPR. Move to a cool area; loosen clothing; make person lie down; and if the person is conscious, offer sips of cool water. Fainting may also be due to other illnesses.
Heat exhaustion	Fluid loss and inadequate salt and water intake causes a body's cooling system to start to break down.	Heavy sweating; cool moist skin; body temperature over 38°C; weak pulse; normal or low blood pressure; tired and weak; nausea and vomiting; very thirsty; panting or breathing rapidly; vision may be blurred.	GET MEDICAL AID. This condition can lead to heat stroke, which can kill. Move the person to a cool shaded area; loosen or remove excess clothing; provide cool water to drink; fan and spray with cool water.
Heat stroke	If a person's body has used up all its water and salt reserves, it will stop sweating. This can cause body temperature to rise. Heat stroke may develop suddenly or may follow from heat exhaustion.	High body temperature (over 41°C) and any one of the following: the person is weak, confused, upset or acting strangely; has hot, dry, red skin; a fast pulse; headache or dizziness. In later stages, a person may pass out and have convulsions. AN IMMEDIATE MEDICAL EMERGENCY. PROMPT ACTION MAY SAVE THE CASUALTY'S LIFE.	CALL AMBULANCE. This condition can kill a person quickly. Remove excess clothing; fan and spray the person with cool water; offer sips of cool water if the person is conscious.

Table courtesy of the Ontario Ministry of Labour: www.labour.gov.on.ca/english/hs/guidelines/gl_heat.html

WHAT FACTORS ARE USED TO ASSESS HEAT STRESS RISK?

Factors that should be considered in assessing heat stress include

- personal risk factors
- environmental factors
- job factors.

Personal risk factors

It is difficult to predict just who will be affected by heat stress and when, because individual susceptibility varies. There are, however, certain physical conditions that can reduce the body's natural ability to withstand high temperatures:

- **Weight**
Workers who are overweight are less efficient at losing heat.
- **Poor physical condition**
Being physically fit aids your ability to cope with the increased demands that heat places on your body.
- **Previous heat illnesses**
Workers are more sensitive to heat if they have experienced a previous heat-related illness.
- **Age**
As the body ages, its sweat glands become less efficient. Workers over the age of 40 may therefore have trouble with hot environments. Acclimatization to the heat and physical fitness can offset some age-related problems.
- **Heart disease or high blood pressure**
In order to pump blood to the skin and cool the body, the heart rate increases. This can cause stress on the heart.
- **Recent illness**
Workers with recent illnesses involving diarrhea, vomiting, or fever have an increased risk of dehydration and heat stress because their bodies have lost salt and water.
- **Alcohol consumption**
Alcohol consumption during the previous 24 hours leads to dehydration and increased risk of heat stress.
- **Medication**
Certain drugs may cause heat intolerance by reducing sweating or increasing urination. People who work in a hot environment should consult their physician or pharmacist before taking medications.
- **Lack of acclimatization**
When exposed to heat for a few days, the body will adapt and become more efficient in dealing with raised environmental temperatures. This process is called acclimatization. Acclimatization usually takes 6 to 7 days. Benefits include
 - lower pulse rate and more stable blood pressure
 - more efficient sweating (causing better evaporative cooling)
 - improved ability to maintain normal body temperatures.

Acclimatization may be lost in as little as three days away from work. People returning to work after a holiday or long weekend—and their supervisors—should understand this. Workers should be allowed to gradually re-acclimatize to work conditions.

Environmental factors

Environmental factors such as ambient air temperature, air movement, and relative humidity can all affect an individual's response to heat. The body exchanges heat with its surroundings mainly through radiation and sweat evaporation. The rate of evaporation is influenced by humidity and air movement.

Radiant Heat

Radiation is the transfer of heat from hot objects through air to the body. Working around heat sources such as kilns or furnaces will increase heat stress. Additionally, working in direct sunlight can substantially increase heat stress. A worker is far more comfortable working at 24°C under cloudy skies than working at 24°C under sunny skies.

Humidity

Humidity is the amount of moisture in the air. Heat loss by evaporation is hindered by high humidity but helped by low humidity. As humidity rises, sweat tends to evaporate less. As a result, body cooling decreases and body temperature increases.

Air Movement

Air movement affects the exchange of heat between the body and the environment. As long as the air temperature is less than the worker's skin temperature, increasing air speed can help workers stay cooler by increasing both the rate of evaporation and the heat exchange between the skin surface and the surrounding air.

Job factors

Clothing and Personal Protective Equipment (PPE)

Heat stress can be caused or aggravated by wearing PPE such as fire- or chemical-retardant clothing. Coated and non-woven materials used in protective garments block the evaporation of sweat and can lead to substantial heat stress. The more clothing worn or the heavier the clothing, the longer it takes evaporation to cool the skin. Remember too that darker-coloured clothing absorbs more radiant heat than lighter-coloured clothing.



Workload

The body generates more heat during heavy physical work. For example, construction workers shoveling sand or laying brick in hot weather generate a tremendous amount of heat and are at risk of developing heat stress without proper precautions. Heavy physical work requires

Careful evaluation even at temperatures as low as 23°C to prevent heat disorders. This is especially true for workers who are not acclimatized to the heat.



ARE THERE MEASURES FOR EVALUATING HEAT STRESS RISK?

To prevent heat stress, scientists from the World Health Organization (WHO) have determined that workers should not be exposed to environments that would cause their internal body temperature to exceed 38°C. The only true way of measuring internal body temperature is rectally (oral or inner ear measurements are not as accurate). As an alternative, the American Conference of Governmental Industrial Hygienists (ACGIH) has developed a method of assessing heat stress risk based on a wet bulb globe temperature (WBGT) threshold (Table 2).

This method of assessment involves the three main components of the heat burden experienced by workers:

- 1) thermal environment
- 2) type of work
- 3) type of clothing.

Thermal environment

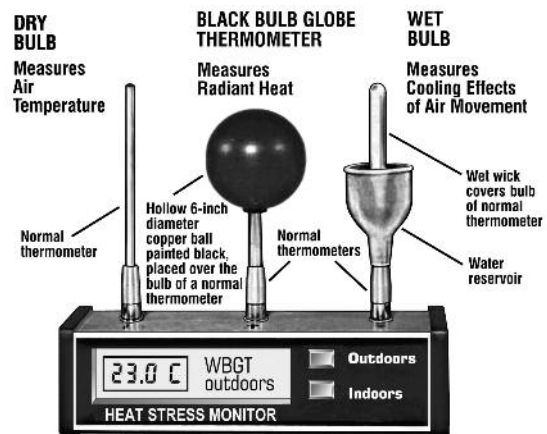
The first factor in assessing heat stress is the thermal environment as measured by WBGT index. WBGT is calculated in degrees Celsius using a formula which incorporates the following three environmental factors:

- air temperature
- radiant heat (heat transmitted to the body through the air from hot objects such as boilers or shingles heated by the sun)
- cooling effects of evaporation caused by air movement (humidity).

To measure WBGT, a heat stress monitor consisting of three types of thermometers is required:

- 1) A normal thermometer called a **dry bulb thermometer** is used to measure air temperature.
- 2) Radiant heat is measured by a **black bulb globe thermometer**. This consists of a hollow, 6-inch diameter copper ball painted flat black and placed over the bulb of a normal thermometer.
- 3) A **wet bulb thermometer** measures the cooling effect of evaporation caused by air movement (wind or fan). It consists of a normal thermometer wrapped in a wick kept moist at all times. As air moves through the wet wick, water evaporates and cools the thermometer in much the same way that sweat evaporates and cools the body.

HEAT STRESS MONITOR



Heat stress monitors currently available calculate WBGT automatically. The equipment required and the method of measuring WBGT can be found in the ACGIH booklet *TLVs® and BEIs®: Threshold Limit Values... Biological Exposure Indices*. The booklet also outlines permissible exposure limits for heat stress. Older instruments, however, require calculation by the operator.

Calculation depends on whether sunlight is direct (outdoors) or not (indoors).

Working outdoors in direct sunlight

For work in direct sunlight WBGT is calculated by taking 70% of the wet bulb temperature, adding 20% of the black bulb temperature, and 10% of the dry bulb temperature.

$$\text{WBGT (out)} = [70\% (0.7) \times \text{wet bulb temperature}] + [20\% (0.2) \times \text{black bulb globe temperature}] + [10\% (0.1) \times \text{dry bulb temperature}]$$

Working indoors (no sunlight)

For work indoors or without direct sunlight, WBGT is calculated by taking 70% of the wet bulb temperature and adding 30% of the black bulb temperature.

$$\text{WBGT (in)} = [70\% (0.7) \times \text{wet bulb temperature}] + [30\% (0.3) \times \text{black bulb globe temperature}]$$

Example

Suppose it's a bright sunny day and a crew of roofers is working 20 feet above ground. Our assessment yields the following readings:

Wet bulb temperature (cooling effects of evaporation) = 20°C

Black bulb globe temperature (radiant heat) = 36°C

Dry bulb temperature (air temperature) = 33°C

Using the formula for work in direct sunlight, we calculate as follows:

$$\begin{aligned} \text{WBGT} &= (0.7 \times \text{wet bulb temperature}) + (0.2 \times \text{black bulb globe temperature}) + (0.1 \times \text{dry bulb temperature}) \\ &= (0.7 \times 20) + (0.2 \times 36) + (0.1 \times 33) \\ &= 14 + 7.2 + 3.3 \end{aligned}$$

WBGT (outdoors) = 24.5 °C

Type of work

The second factor in assessing heat stress is the type of work being performed. Following are the four categories, with some examples of each:

Light work	<ul style="list-style-type: none"> Using a table saw Some walking about Operating a crane, truck, or other vehicle Welding
Moderate work	<ul style="list-style-type: none"> Laying brick Walking with moderate lifting or pushing Hammering nails Tying rebar Raking asphalt Sanding drywall
Heavy work	<ul style="list-style-type: none"> Carpenter sawing by hand Shoveling dry sand Laying block Ripping out asbestos Scraping asbestos fireproofing material
Very Heavy Work	<ul style="list-style-type: none"> Shoveling wet sand Lifting heavy objects

Type of clothing

Free movement of cool, dry air over the skin maximizes heat removal. Evaporation of sweat from the skin is usually the major method of heat removal. WBGT-based heat exposure assessments are based on a traditional summer work uniform of long-sleeved shirt and long pants. With regard to clothing, the measured WBGT value can be adjusted according to Table 1.

TABLE 1: Additions to measured WBGT values for some types of clothing

Clothing Type	Addition to WBGT
Summer work uniform	0
Cloth (woven material) overalls	+3.5
Double-cloth overalls	+5

Note: These additions do not apply to encapsulating suits, thermal-insulated clothing, or clothing impermeable or highly resistant to water vapour or air movement. Special garments such as these, and multiple layers of clothing, severely restrict sweat evaporation and heat removal. As a result, body heat may produce life-threatening heat stress even when environmental conditions are considered cool.

Determine work/rest schedules

The WBGT can be used to determine work/rest schedules for personnel under various conditions. Knowing that the WBGT is 24.5°C in the example above, you can refer to Table 2 and determine that workers accustomed to the heat (“acclimatized”), wearing summer clothes, and doing “heavy” work can perform continuous work (100% work).

Suppose work is being performed indoors at a pulp and paper mill under the following conditions:

- Workers are wearing cloth coveralls.
- Boilers are operational.

- Work load is moderate.
- General ventilation is present.

Our assessment yields the following readings:

Wet bulb temperature
(cooling effects of evaporation) = 23°C
Black bulb globe temperature (radiant heat) = 37°C
Dry bulb temperature (air temperature) = 34°C

Using the formula for work indoors, we calculate as follows:

WBGT = (0.7 x wet bulb temperature)
+ (0.3 x black bulb globe temperature)
= (0.7 x 23) + (0.3 x 37) = 27.2°C
Addition for cloth overalls
(Table 1) = 3.5
WBGT (indoors) = 30.7°C

Referring to Table 2, we determine that workers accustomed to the heat (acclimatized), wearing cloth overalls, and performing “moderate” work can work 15 minutes per hour (25% work; 75% rest).

The WBGT must never be used as an indicator of safe or unsafe conditions. It is only an aid in recognizing heat stress. The ultimate assessment and determination of heat stress must lie with the individual worker or co-worker trained to detect its symptoms. Supervisors must allow individual workers to determine if they are capable of working in heat.

Table 2 is intended for use as a screening step only. Detailed methods of analysis are fully described in various technical and reference works. Contact CSAO for further information.

TABLE 2: Screening Criteria for Heat Stress Exposure using WBGT

(Values are WBGTs in °C. These are NOT air temperatures.)

Work Demands	Acclimatized				Unacclimatized			
	Light	Moderate	Heavy	Very Heavy	Light	Moderate	Heavy	Very Heavy
100% Work	29.5	27.5	26		27.5	25	22.5	
75% Work; 25% Rest	30.5	28.5	27.5		29	26.5	24.5	
50% Work; 50% Rest	31.5	29.5	28.5	27.5	30	28	26.5	25
25% Work; 75% Rest	32.5	31	30	29.5	31	29	28	26.5

Notes

- WBGT values are expressed in °C. WBGT is NOT air temperature.
- WBGT-based heat exposure assessments are based on a traditional summer work uniform of long-sleeved shirt and long pants.
- If work and rest environments are different, hourly time-weighted averages (TWA) should be calculated and used. TWAs for work rates should also be used when the demands of work vary within the hour.
- Because of the physiological strain produced by very heavy work among less fit workers, the table does not provide WBGT values for very heavy work in the categories *100% Work* and *75% Work; 25% Rest*.

Use of the WBGT is not recommended in these cases. Detailed and/or physiological monitoring should be used instead.

- Consult the latest issue of *TLVs® and BEIs®: Threshold Limit Values® and Biological Exposure Indices®*, published by the American Conference of Governmental Industrial Hygienists, for guidance on how to properly measure, interpret, and apply the WBGT.

Because of the variable and transient nature of construction sites it may not be practical to measure the WBGT. It's therefore reasonable to ask if there are other ways to evaluate heat stress risk.

IS IT POSSIBLE TO USE THE HUMIDEX TO EVALUATE HEAT STRESS RISK?

The humidex is a measure of discomfort based on the combined effect of excessive humidity and high temperature. As noted already, heat-related disorders involve more than air temperature and humidity. **Other factors—air movement, workload, radiant heat sources, acclimatization—must also be considered in assessing heat stress.** But humidex readings can signal the need to implement procedures for controlling heat stress in the workplace.

Environment Canada provides the following humidex guidelines.

- Where humidex levels are less than 29°C, most people are comfortable.
- Where humidex levels range from 30°C to 39°C, people experience some discomfort.
- Where humidex levels range from 40°C to 45°C, people are uncomfortable.
- Where humidex levels are over 45°C, many types of labour must be restricted.

In the hazard alert *Heat Stress and Heat Stroke in Outdoor Work*, the Ontario Ministry of Labour recommends using the WBGT to evaluate heat stress. However, the humidex can be permissible instead if equivalency is demonstrated.

In the absence of any heat-related incidents, a Ministry of Labour inspector is not likely to issue orders against any employer with a comprehensive heat stress program based on the humidex.

If the humidex rather than the WBGT is being used to monitor conditions, the employer should have

- documentation describing the heat stress policy
- training that emphasizes recognition of heat stress symptoms
- thorough investigation of any heat stress incidents to determine whether the heat stress policy is deficient.

Because humidex readings can vary substantially from point to point it is important that a reading be taken at the actual workplace.

See the Appendix for a five-step approach for using the humidex.

HOW CAN HEAT STRESS BE CONTROLLED?

Heat stress can be controlled through education, engineering, and work procedures. Controls will

- **Protect health**
Illness can be prevented or treated while symptoms are still mild.
- **Improve safety**
Workers are less liable to develop a heat-related illness and have an accident. Heat stress often creeps up without warning. Many heat-induced accidents are caused by sudden loss of consciousness.
- **Increase productivity**
Workers feel more comfortable and are likely to be more productive as a result.

Training and education

According to the U.S. National Institute of Occupational Safety and Health (NIOSH), heat stress training should cover the following components:

- knowledge of heat stress hazards
- recognition of risk factors, danger signs, and symptoms
- awareness of first-aid procedures for, and potential health effects of, heat stroke
- employee responsibilities in avoiding heat stress
- dangers of using alcohol and/or drugs (including prescription drugs) in hot work environments.

Engineering controls

Engineering controls are the most effective means of preventing heat stress disorders and should be the first method of control. Engineering controls seek to provide a more comfortable workplace by using

- reflective shields to reduce radiant heat
- fans and other means to increase airflow in work areas
- mechanical devices to reduce the amount of physical work.

Given the constantly changing nature of construction sites, engineering controls are not usually feasible. Proper work procedures are therefore required to prevent heat stress disorders.

Work procedures

The risks of working in hot construction environments can be diminished if labour and management cooperate to help control heat stress.

Management

- Give workers frequent breaks in a cool area away from heat. The area should not be so cool that it causes cold shock—around 25°C is ideal.
- Increase air movement by using fans where possible. This encourages body cooling through the evaporation of sweat.
- Provide unlimited amounts of cool (not cold) drinking water conveniently located.
- Allow sufficient time for workers to become acclimatized. A properly designed and applied acclimatization program decreases the risk of heat-related illnesses. Such a program exposes employees to work in a hot environment for progressively longer periods. NIOSH recommends that for workers who have had previous experience in hot jobs, the regimen should be
 - 50% exposure on day one
 - 60% on day two

- 80% on day three
- 100% on day four.

For new workers in a hot environment, the regimen should be 20% on day one, with a 20% increase in exposure each additional day.

- Make allowances for workers who must wear personal protective clothing and equipment that retains heat and restricts the evaporation of sweat.
- Schedule hot jobs for the cooler part of the day; schedule routine maintenance and repair work in hot areas for the cooler seasons of the year.
- Consider the use of cooling vests containing ice packs or ice water to help rid bodies of excess heat.

Labour

- Wear light, loose clothing that permits the evaporation of sweat.
- Drink small amounts of water—8 ounces (250 ml)—every half hour or so. Don't wait until you're thirsty.
- Avoid beverages such as tea, coffee, or beer that make you pass urine more frequently.
- Where personal PPE must be worn,
 - use the lightest weight clothing and respirators available
 - wear light-colored garments that absorb less heat from the sun
 - use PPE that allows sweat to evaporate.
- Avoid eating hot, heavy meals. They tend to increase internal body temperature by redirecting blood flow away from the skin to the digestive system.
- Don't take salt tablets unless a physician prescribes them. Natural body salts lost through sweating are easily replaced by a normal diet.

WHAT ARE THE RESPONSIBILITIES OF WORKPLACE PARTIES REGARDING HEAT STRESS?

Employers

The *Occupational Health and Safety Act* and its regulations do not specifically cover worker exposure to heat. However, under the *Occupational Health and Safety Act* employers have a general obligation to protect workers exposed to hot environments. Employers should develop a written health and safety policy outlining how workers in hot environments will be protected from heat stress. As a minimum, the following points should be addressed.

- Adjust work practices as necessary when workers complain of heat stress.
- Make controlling exposures through engineering controls the primary means of control wherever possible.
- Oversee heat stress training and acclimatization for new workers, workers who have been off the job for a while, and workers with medical conditions.
- Provide worker education and training, including periodic safety talks on heat stress during hot weather or during work in hot environments.
- Monitor the workplace to determine when hot conditions arise.
- Determine whether workers are drinking enough water.
- Determine a proper work/rest regime for workers.
- Arrange first-aid training for workers.

When working in a manufacturing plant, for instance, a contractor may wish to adopt the plant's heat stress program if one exists.



Workers

- Follow instructions and training for controlling heat stress.
- Be alert to symptoms in yourself and others.
- Avoid consumption of alcohol, illegal drugs, and excessive caffeine.
- Find out whether any prescription medications you're required to take can increase heat stress.
- Get adequate rest and sleep.
- Drink small amounts of water regularly to maintain fluid levels and avoid dehydration.

APPENDIX

ASSESSING HEAT STRESS HAZARDS USING THE HUMIDEX

WBGT is the most common and useful index for setting heat stress limits, especially when sources of radiant heat are present. It has proven to be adequate when used as part of a program to prevent adverse health effects in most hot environments.

However, taking WBGT measurements properly is quite complicated.

This section provides a simplified version of the WBGT by converting the WBGT into **humidex**. The method was developed by the Occupational Health Clinics for Ontario Workers, Inc. It allows workplace parties to measure heat stress using only workplace temperature and humidity. The following five steps are designed to help workplaces determine whether conditions require action to reduce heat stress.

Step 1: Clothing

- The humidex plan assumes workers are wearing regular summer clothes (light shirt and pants, underwear, and socks and shoes).
- If workers wear cotton overalls on top of summer clothes, add 5°C humidex to the workplace humidex measurement.
- Estimate correction factor for other kinds of clothing by comparing them with cotton overalls (e.g., gloves, hard hat, apron, and protective sleeves might be equivalent to a little less than half the evaporation resistance of overalls, so add 1°C or 2°C humidex).

Step 2: Training

- Measurements by themselves cannot guarantee workers protection from heat stress. It is essential that workers learn to recognize the early signs and symptoms of heat stress and know how to prevent them.
- If it's possible, workers need to be able to alter their pace of work, take rest breaks, and drink in response to early symptoms (a cup of water every 20 minutes). The ideal heat stress response plan would let workers regulate their own pace by "listening to their body."

Step 3: Select a measurement location

- Divide the workplace into zones which have similar heat exposures.
- Select a representative location in each zone where you can take measurements. **Note:** the Humidex Heat Stress Response (Table B) is based on **workplace** measurements, **not** weather station/media reports (temperatures inside buildings do not necessarily correspond with outside temperatures).

Step 4: Measure workplace humidex

- A thermal hygrometer (usually \$20–\$60 at hardware or office supply stores) is a simple way to measure the temperature and relative humidity in your workplace. Avoid placing the thermal hygrometer in direct sunlight or in contact with a hot surface. Once you have the temperature and humidity, use Table A (or the humidex

calculator located at:

http://www.ohcow.on.ca/menuweb/heat_stress_calculator.htm to determine the corresponding humidex value.

- From Table B select Humidex 1 or Humidex 2 according to the amount of physical activity involved with the work and the level of acclimatization. This helps you determine what steps should be taken to reduce the heat stress. Humidex 1 is for moderate unacclimatized and heavy acclimatized work; Humidex 2 is for light unacclimatized work (sitting/standing doing light arm work).

Step 5: Adjust for radiant heat

- For outdoor work in direct sunlight between the hours of 10 am and 5 pm, add 1–2°C (pro-rate according to percentage cloud cover) to your humidex measurement.
- For indoor radiant heat exposures (such as boilers or furnaces), use common sense to judge whether the exposure involves more or less radiant heat than direct sunlight and adjust the 1–2°C correction factor appropriately.

See Table A and Table B on the following pages.

Table A: Humidex Table

Humidex																				
Temp (in °C)	Relative Humidity (in %)																			
	100	95	90	85	80	75	70	65	60	55	50	45	40	35	30	25	20	15	10	Temp (in °C)
49																			50	49
48																			49	48
47																		50	47	47
46	Never ignore someone's symptoms no matter what you measure!																46			
45																	50	47	45	45
44																	49	46	43	44
43																49	47	45	42	43
42															50	48	46	43	41	42
41															48	46	44	42	40	41
40														49	47	45	43	41	39	40
39													49	47	45	43	41	39	37	39
38												49	47	45	43	42	40	38	36	38
37											49	47	45	44	42	40	38	37	35	37
36									50	49	47	45	44	42	40	39	37	35	34	36
35								50	48	47	45	43	42	40	39	37	36	34	33	35
34							49	48	46	45	43	42	40	39	37	36	34	33	31	34
33						50	48	46	44	43	41	40	39	37	36	34	33	32	30	33
32			50			48	46	44	42	41	40	38	37	36	34	33	32	30	29	32
31	50	49	48			44	43	42	40	39	38	37	35	34	33	32	30	29	28	31
30	48	47	46			43	42	40	39	37	36	35	34	33	31	30	29	28	27	30
29	46	45	43			42	41	40	39	37	36	35	34	33	31	30	29	28	27	29
28	43	42	41			40	39	38	37	35	34	33	32	31	30	29	28	27	26	28
27	41	40	39			38	37	36	35	34	33	32	31	30	29	28	27	26	25	27
26	39	38	37			36	35	34	33	32	31	30	29	28	27	26	25			26
25	37	36	35			34	33	33	32	31	30	29	28	27	26	25				25
24	35	34	33			33	32	31	30	29	28	27	26	25						24
23	33	32	31			31	30	29	28	27	26	25								23
22	31	30	30			29	28	27	27	26	25									22
21	29	29	28			27	26	26	25											21
	100%	95%	90%	85%	80%	75%	70%	65%	60%	55%	50%	45%	40%	35%	30%	25%	20%	15%	10%	

Table B: Response

Humidex 1 (moderate unacclimatized and heavy acclimatized work)	Response Never ignore someone's symptoms no matter what you measure!	Humidex 2 light unacclimatized work (sitting/standing doing light arm work)
30-37	Low <ul style="list-style-type: none"> Alert workers to potential for heat stress. Ensure access to water. 	34-41
38-39	Medium <ul style="list-style-type: none"> Reduce physical activity (e.g., slower pace, double up, breaks). Drink a cup of water every 20-30 minutes. 	42-43
40-42	Moderate <ul style="list-style-type: none"> Reduce physical activity further. Drink a cup of water every 15-20 minutes. 	44-45
43-44	High <ul style="list-style-type: none"> Ensure sufficient rest and recovery time. Severely curtail physical activity. Drink a cup of water every 10-15 minutes. 	46-48
45 or over	Extreme <ul style="list-style-type: none"> It is hazardous to continue physical activity. 	49 or over

7 COLD STRESS

Contents

- Core temperature
- Wind chill
- Hypothermia
- Frostbite
- Risk factors
- Controls
- Exposure limits

Cold stress or **hypothermia** can affect construction workers who are not protected against cold. The cold may result naturally from weather conditions or be created artificially, as in refrigerated environments.

Cold is a physical hazard in many construction workplaces. When the body is unable to warm itself, serious cold-related illnesses and injuries may occur, leading to permanent tissue damage and even death.

Construction workplaces exposed to cold, wet, and/or windy conditions include

- roofs
- open or unheated cabs
- bridges or other projects near large bodies of water
- large steel structures that retain cold or are exposed to cold
- high buildings open to the wind
- refrigerated rooms, vessels, and containers.

This section provides information on

- effects of overexposure to cold
- factors that can worsen these effects
- control measures.

Knowing this information can help construction workers avoid hypothermia and frostbite.

CORE TEMPERATURE

The body tries to maintain an internal (core) temperature of approximately 37°C (98.6°F). This is done by reducing heat loss and increasing heat production.

Under cold conditions, blood vessels in skin, arms, and legs constrict, decreasing blood flow to extremities. This minimizes cooling of the blood and keeps critical internal organs warm. At very low temperatures, however, reducing blood flow to the extremities can result in lower skin temperature and higher risk of frostbite.

WIND CHILL

Wind chill involves the combined effect of air temperature and air movement. The wind-chill cooling rate is defined

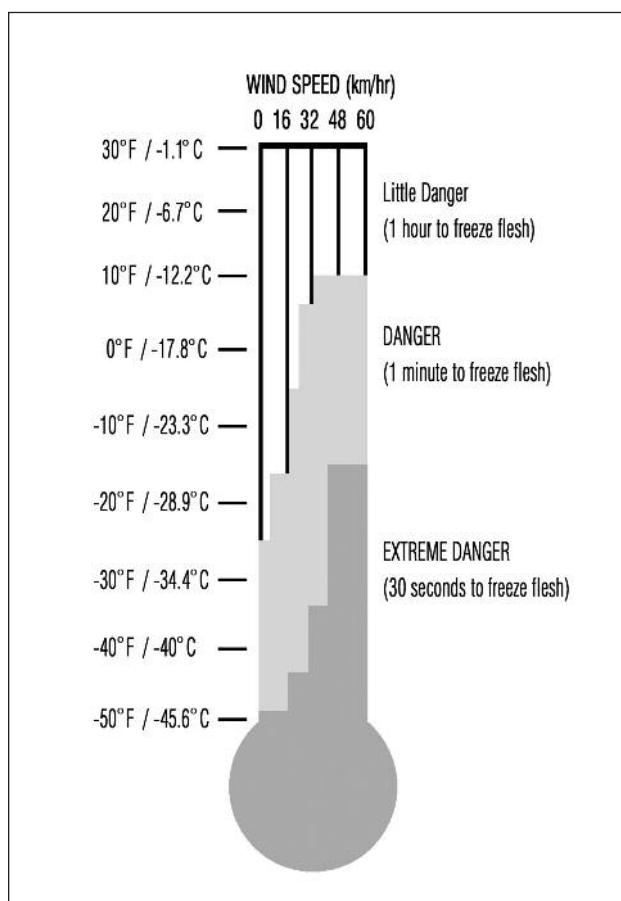


Chart 1: Equivalent chill temperatures

Adapted from *TLVs® and BEIs®: Threshold Limit Values® for Chemical Substances and Physical Agents and Biological Exposure Indices®*, American Conference of Governmental Industrial Hygienists, 1999.

as heat loss (expressed in watts per metre squared) resulting from the effects of air temperature and wind velocity upon exposed skin.

The higher the wind speed and the lower the temperature in the work environment, the greater the insulation value of the protective clothing required.

Chart 1 provides equivalents between air temperatures with and without wind. For example, -12.2°C with a wind of 48 km/h is equivalent to -45°C with no wind. When air speed and temperature produce an equivalent chill temperature of -32°C (-25.6°F), continuous skin exposure should not be permitted. Unprotected skin will freeze only at temperatures below -1°C (30.2°F), regardless of wind speed.

When weather information is not available, the following signs may help to estimate wind speeds in the field:

- 8 km/h (5 mph) light flag just moves
- 16 km/h (10 mph) light flag is fully extended by the wind
- 24 km/h (15 mph) raises a newspaper sheet off the ground
- 32 km/h (20 mph) wind capable of blowing snow.

Exposure to cold causes two major health problems: frostbite and hypothermia.

HYPOTHERMIA—*signs and symptoms*

When the body can no longer maintain core temperature by constricting blood vessels, it shivers to increase heat production. Maximum severe shivering develops when the body temperature has fallen to 35°C (95°F).

The most critical aspect of hypothermia is the body's failure to maintain its deep core temperature. Lower body temperatures present the following signs and symptoms:

- persistent shivering—usually starts when core temperature reaches 35°C (95°F)
- irrational or confused behaviour
- reduced mental alertness
- poor coordination, with obvious effects on safety
- reduction in rational decision-making.

In addition, acute exertion in cold can constrict blood vessels in the heart. This is particularly important for older workers or workers with coronary disease who may have an increased risk of heart attack.

HYPOTHERMIA—*stages*

Mild

Early signs of hypothermia include

- shivering
- blue lips and fingers
- poor coordination.

Moderate

The next stage includes

- mental impairment
- confusion
- poor decision-making
- disorientation
- inability to take precautions from the cold
- heart slowdown
- slow breathing.

Severe

In severe cases, hypothermia resembles death. Patients must be treated as though they are alive.

Symptoms of severe hypothermia include

- unconsciousness
- heart slowdown to the point where pulse is irregular or difficult to find
- no shivering
- no detectable breathing.

HYPOTHERMIA—*first aid*

Stop further cooling of the body and provide heat to begin rewarming.

- Carefully remove casualty to shelter. Sudden movement or rough handling can upset heart rhythm.
- Keep casualty awake.
- Remove wet clothing and wrap casualty in warm covers.
- Rewarm neck, chest, abdomen, and groin—but not extremities.
- Apply direct body heat or use safe heating devices.
- Give warm, sweet drinks, but only if casualty is conscious.
- Monitor breathing. Administer artificial respiration if necessary.
- Call for medical help or transport casualty carefully to nearest medical facility.

FROSTBITE—*signs and symptoms*

Frostbite is a common injury caused by exposure to severe cold or by contact with extremely cold objects.

Frostbite occurs more readily from touching cold metal objects than from exposure to cold air. That's because heat is rapidly transferred from skin to metal.

The body parts most commonly affected by frostbite are face, ears, fingers, and toes. When tissue freezes, blood vessels are damaged. This reduces blood flow and may cause gangrene.

Frostbite symptoms vary, are not always painful, but often include a sharp, prickling sensation.

The first indication of frostbite is skin that looks waxy and feels numb. Once tissues become hard, the case is a severe medical emergency. Severe frostbite results in blistering that usually takes about ten days to subside.

Once damaged, tissues will always be more susceptible to frostbite in future.

FROSTBITE—*first aid*

- Warm frostbitten area gradually with body heat. Do not rub.
- Don't thaw hands or feet unless medical aid is distant and there is no chance of refreezing. Parts are better thawed at a hospital.
- Apply sterile dressings to blisters to prevent breaking. Get medical attention.

RISK FACTORS

Various medical conditions can increase the risk of cold injury:

- heart disease

- asthma/bronchitis
- diabetes
- vibration/white finger disease.

Check with your health practitioner to learn whether medications you are taking may have adverse effects in a cold environment.

CONTROLS

The best protection against cold-related health risks is to be aware and be prepared. Workers should recognize the signs and symptoms of overexposure in themselves and others. Pain in the extremities may be the first warning sign. Any worker shivering severely should come in out of the cold.

General

- Ensure that the wind-chill factor is understood by workers, especially those working on bridges or out in the open on high buildings.
- Ensure that workers are medically fit to work in excessive cold, especially those subject to the risk factors highlighted in the previous section.
- Make sure that workers understand the importance of high-caloric foods when working in the cold. Warm sweet drinks and soups should be arranged at the work site to maintain caloric intake and fluid volume. Coffee should be discouraged because it increases water loss and blood flow to extremities.
- Personnel working in isolated cold environments, whether indoors or outdoors, should have backup.
- Provide hot drinks and regular breaks under extremely cold working conditions.

Clothing

Select protective clothing to suit the cold, the job, and the level of physical activity.

- Wear several layers of clothing rather than one thick layer. The air captured between layers is an insulator.
- Wear synthetic fabrics such as polypropylene next to the skin because these wick away sweat. Clothing should not restrict flexibility.
- If conditions are wet as well as cold, ensure that the outer clothing worn is waterproof or at least water-repellent. Wind-resistant fabrics may also be required under some conditions.
- At air temperatures of 2°C (35.6°F) or less, workers whose clothing gets wet for any reason must be immediately given a change of clothing and be treated for hypothermia.
- Encourage the use of hats and hoods to prevent heat loss from the head and to protect ears. Balaclavas or other face covers may also be necessary under certain conditions.
- Tight-fitting footwear restricts blood flow. Footwear should be large enough to allow wearing either one

Hand Protection

Manual dexterity is essential to safety and production.

- Fine work performed with bare hands for more than 10-20 minutes in an environment below 16°C (60.8°F) requires special measures to keep workers' hands warm. These measures may include warm air jets, radiant heaters (fuel burning or electric), or contact warm plates.
- Metal handles of tools and control bars should be covered by thermal insulating material for temperatures below -1°C (30.2°F).
- Workers should wear gloves where fine manual dexterity is not required and the air temperature falls below 16°C (60.8°F) for sedentary, 4°C (39.2°F) for light, and -7°C (19.4°F) for moderate work.
- To prevent contact frostbite, workers should wear insulated gloves when surfaces within reach (especially metallic surfaces) are colder than -7°C (19.4°F). Warn workers to avoid skin contact with these surfaces.
- Tools and machine controls to be used in cold conditions should be designed for operation by gloved hands.

thick or two thin pairs of socks. Wearing too many socks can tighten the fit of footwear and harm rather than help.

- Workers who get hot while working should open their jackets but keep hats and gloves on.

Shelter

For work performed continuously in the cold, allow rest and warm-up breaks (see table on the next page). Heated shelters such as trailers should be available nearby. Encourage workers to use these shelters at regular intervals depending on the wind-chill factor.

Workers showing signs of shivering, frostbite, fatigue, drowsiness, irritability, or euphoria should immediately return to the shelter.

Workers entering the shelter should remove their outer layer of clothing and loosen other clothing to let sweat evaporate. In some cases, a change of clothing may be necessary.

Training

Before working in extreme cold, workers should be instructed in safety and health procedures.

Training should cover

- proper clothing and equipment
- safe work practices
- guidelines for eating and drinking
- risk factors that increase the health effects of cold exposure

- how to recognize signs and symptoms of frostbite
- how to recognize signs and symptoms of hypothermia
- appropriate first aid treatment, including rewarming procedures.

EXPOSURE LIMITS

Ontario has no legislated exposure limits for work in cold environments. The table below was developed by the Saskatchewan Department of Labour and adopted by the American Conference of Governmental Industrial Hygienists (ACGIH). It indicates Threshold Limit Values for properly clothed personnel working at temperatures below freezing.



Work/Warm-up Schedule for a Four-Hour Shift

Air temperature (sunny sky)		No noticeable wind		8 km/h wind (5 mph)		16km/h wind (10 mph)		24 km/h wind (15mph)		32 km/h wind (20 mph)	
°C (approx.)	°F (approx.)	Max work period	No. of breaks	Max work period	No. of breaks	Max work period	No. of breaks	Max work period	No. of breaks	Max work period	No. of breaks
-26° to -28°	-15° to -19°	Normal breaks	1	Normal breaks	1	75 minutes	2	55 minutes	3	40 minutes	4
-29° to -30°	-20° to -24°	Normal breaks	1	75 minutes	2	55 minutes	3	40 minutes	4	30 minutes	5
-32° to -34°	-25° to -29°	75 minutes	2	55 minutes	3	40 minutes	4	30 minutes	5	Non-emergency work should stop	
-35° to -37°	-30° to -34°	55 minutes	3	40 minutes	4	30 minutes	5	Non-emergency work should stop			
-38° to -39°	-35° to -39°	40 minutes	4	30 minutes	5	Non-emergency work should stop					
-40° to -42°	-40° to -44°	30 minutes	5	Non-emergency work should stop							
-43° and below	-45° and below	Non-emergency work should stop									

Source: Occupational Health and Safety Division, Saskatchewan Department of Labour

Notes

- This table applies to any 4-hour work period of moderate-to-heavy work with warm-up periods of ten minutes in a warm location and with an extended break (e.g., lunch) at the end of the 4-hour work period in a warm location. For light-to-moderate work (limited physical movement) apply the schedule one step lower. For example, at -35°C (-30°F) with no noticeable wind (row 4), a worker at a job with little physical movement should have a maximum work period of 40 minutes with 4 breaks in a 4-hour period (row 5).
- Here is a rough guideline for using the chart if only the wind-chill cooling rate is available: 1) initiate special warm-up breaks at a wind chill cooling rate of about 1750 W/m²; 2) cease all non-emergency work at or before a wind chill of 2250 W/m². In general, the warm-up schedule slightly undercompensates for the wind at the warmer temperatures, assuming acclimatization and clothing appropriate for winter work. On the other hand, the chart slightly overcompensates for the actual temperatures in the colder ranges because windy conditions rarely prevail at extremely low temperatures.
- The chart applies only to workers in dry clothing.

8 BACK CARE

Nearly 25% of the lost-time injuries in construction are related to the back. More than half of these injuries result from lifting excessive weight or lifting incorrectly.

To prevent injuries, you need

1. proper posture
2. correct lifting techniques
3. regular exercise.

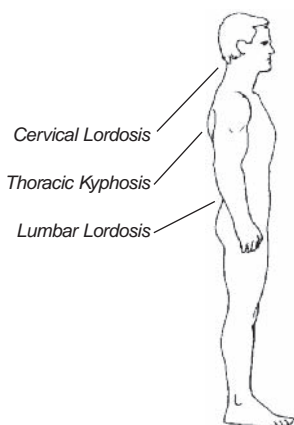
Posture

Correct posture is not an erect, military pose. It means maintaining the naturally occurring curves in your spine.

You have two inward curves – at the neck and low back – and one outward curve at the upper back.

Keeping your spine aligned in this manner reduces everyday stresses on your back and minimizes the effects of the normal aging process on the spine.

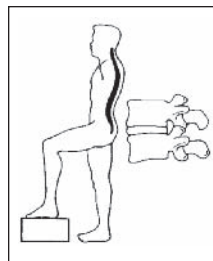
When working in a crouched, bent, or stooping position for a prolonged period, take regular breaks by standing up and bending backwards three times.



Correct Posture

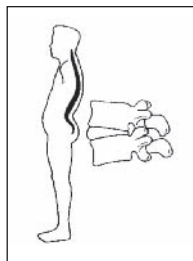
You have two inward curves (lordosis), one each at the neck and low back, and one outward curve (kyphosis) at the upper back.

Common Posture



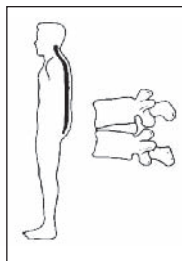
Normal

Prolonged standing often causes an increased curve in your back. Elevating one foot on a stool or any other object (a phone book or brick will do) will take stress off the lower spine.



Sway Back

An increased curve in your lower back will jam the vertebrae together (sway back). If held too long, the position will cause lower back muscles and ligaments to tighten and lead to lower back pain.



Flat Back

Too little curve (flat back) will put extra pressure on the front of your discs. This may contribute to disc problems and pain.



For bench work, the right height is vital.



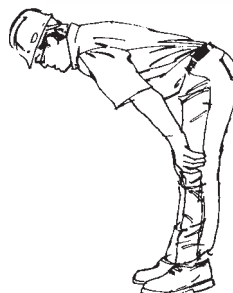
Precision work



Light work



Heavy work



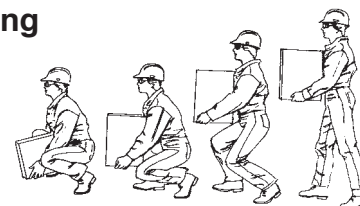
Work Overhead

When working overhead in an arched position for prolonged periods, take regular breaks by returning to stable footing and bending forward three times.

If possible avoid working on ladders. Use scaffolds instead, especially for long-term tasks or for jobs where you must handle heavy materials.

Materials Handling

Proper Lifting



1. Plan your move.
 - Size up the load and make sure pathway is clear.
 - Get help as needed.
 - Use a dolly or other device if necessary.
2. Use a wide-balanced stance with one foot slightly ahead of the other.
3. Get as close to the load as possible.
4. Tighten your stomach muscles as the lift begins.
5. When lifting, keep your lower back in its normal arched position and use your legs to lift.
6. Pick up your feet and pivot to turn – don't twist your back.
7. Lower the load slowly, maintaining the curve in your lower back.

Your back can manage most lifts – if you lift correctly.

Avoid lifting above shoulder height. This causes the back to arch, placing heavy stress on the small joints of the spine.

Do not catch falling objects. Your muscles may not have time to coordinate properly to protect the spine.

Push rather than pull. Pushing allows you to maintain the normal curves in your back.

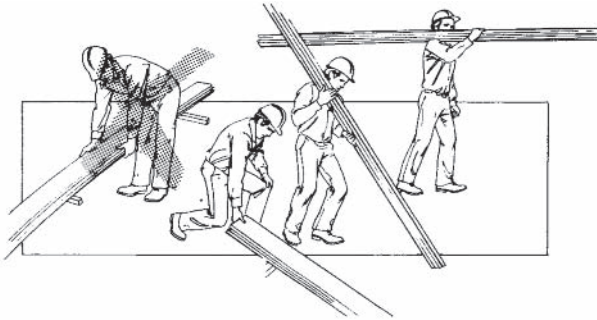
Weight Transfer

Pull the object toward you while transferring your weight to the lift side.

Lift only to the level required.

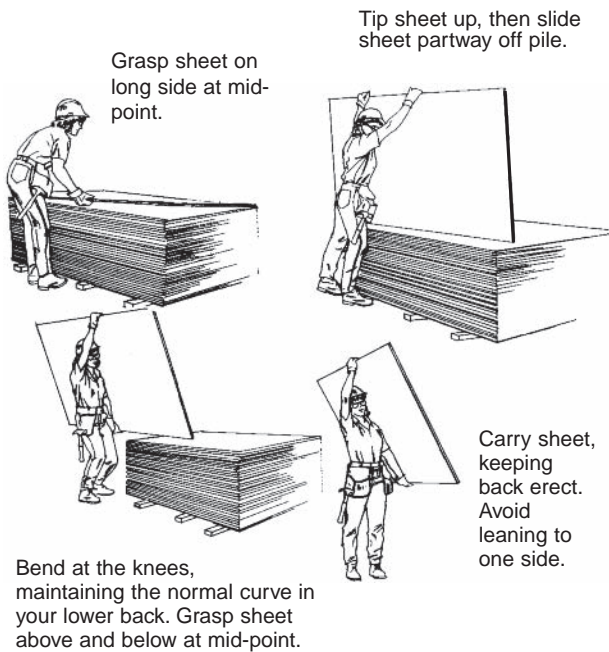
Shift your weight to your other leg while pushing the object into position.

Sheet Materials

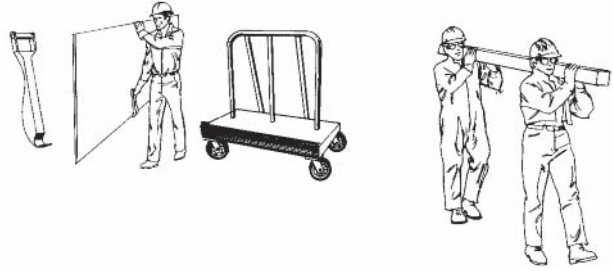


If sheets are on the floor, use the same technique as for lifting long lumber. Lift one end first.

When you handle sheet materials, use proper techniques to protect your back. Where possible, store sheets at a convenient height and above ground on timbers or trestles.



For long carries, use carrying handles. Better yet, if surface is smooth and hard use a drywall cart.



Two-Person Lift

Lifters should be of similar height. Before starting they should decide on lifting strategy and who will take charge.

For a two-person lift of a long load, the lifter who takes charge must see that the load is carried on the same side, with a clear line of vision. Begin by lifting load from ground to waist height. Then lift the load from waist to shoulder.

Carrying on Stairs

Use your stomach muscles to help support and protect your back. If possible, the tallest and/or strongest person should be at the bottom of the load.

Balance

Avoid one-handed carrying if possible. Try to distribute the weight evenly on each side. If you can't avoid one-handed carrying, such as with a single pail, hold the free arm either straight out or on your hip as a counterbalance.

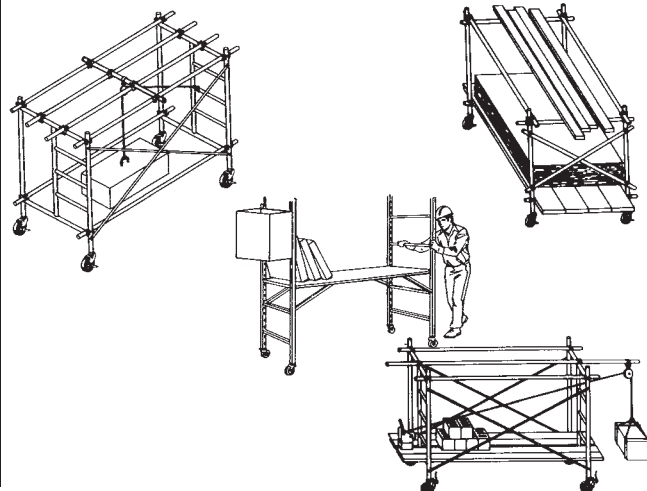
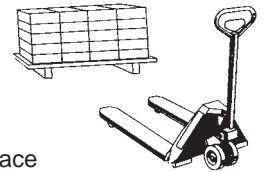


Mechanical Help

Use a cart or dolly for transporting tools and equipment wherever possible.

Consider using pallets where surface conditions allow.

Rolling frame scaffolds with a few tube-and-clamp components may be useful for moving heavy objects such as motors or drives where other devices such as forklifts are not available.





Wheelbarrows with dual wheels are a great improvement over single wheels. Better balance and increased flotation over soft ground make wheeling easier on the back.

Lift tables with casters for heavy components can be helpful. These tables are light, carry loads of

several hundred pounds, and have adjustable heights from one to several feet.

Exercise

Construction work strengthens some muscles while others become shorter and weaker, creating a muscle imbalance. A regular exercise program can help to prevent this from happening.

A good exercise program should consist of four basic parts:

1. warm-up
2. main workout
3. strength and stretch
4. cool-down.

Warm-Up

This is a general exercise program only. Before starting any exercise program, consult your doctor first.

If you have any concerns or experience any pain while doing the exercises, stop and consult your doctor.

1. March in Place

Start: Stand in position.

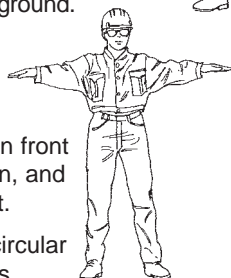
Action: Pump arms and legs in opposite directions. Make sure heels contact ground. Continue 3 to 5 minutes.



2. Arm Circles

Start: Stand with arms raised horizontally and slightly in front of shoulders, palms down, and feet shoulder-width apart.

Action: Rotate arms in forward circular motion for 15-30 seconds. Relax. Repeat 3-5 times.



Stretching Program

The following stretching exercises are of greatest value before work starts. They may, however, be done at any convenient time. Whenever they are done, a brief warm-up (walking briskly or jogging on the spot) is most beneficial.

The exercises should be performed in a slow, controlled manner and held in a sustained stretch. Avoid bouncy, jerky movements which may tear muscle fibres.

3. Knees to Chest

Start: Support yourself securely with one hand.

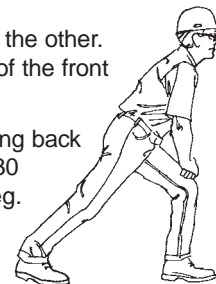
Action: Pull your knee toward your chest and grasp around your knee with your free hand. Hold the stretch for 30 seconds. Lower your leg to the ground and repeat with the other leg. Repeat three times for each leg.



4. Hip Stretch

Start: Stand with one foot in front of the other. Place hands above the knee of the front leg.

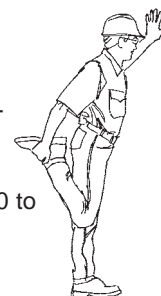
Action: Gently bend front knee, keeping back foot flat on the floor. Hold 20-30 seconds. Repeat with other leg. Repeat three times for each leg.



5. Thigh Stretch

Start: Support yourself with one hand on something secure.

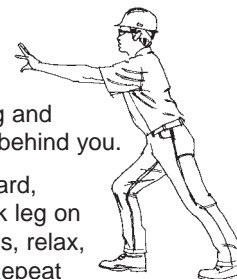
Action: Bend your leg back and grasp your ankle with your free hand. Gently pull your ankle toward your body, keeping your trunk straight. Hold 20 to 30 seconds; repeat with other leg. Repeat three times for each leg.



6. Calf Stretch

Start: Stand slightly away from a solid support and lean on it with your outstretched hands. Bend the forward leg and place the other leg straight behind you.

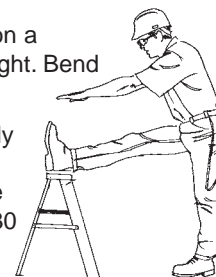
Action: Slowly move your hips forward, keeping the heel of the back leg on the ground. Hold 30 seconds, relax, and repeat with other leg. Repeat three times for each leg.



7. Hamstring Stretch

Start: Place the back of your heel on a platform at a comfortable height. Bend your supporting leg slightly.

Action: Looking straight ahead, slowly bend forward at the hips until you feel a good stretch at the back of the raised leg. Hold 30 seconds and repeat with other leg. Repeat three times for each leg.



9 MOULDS

More and more construction firms are involved in removing toxic moulds from contaminated buildings. This section explains

- what moulds are
- where they are found
- why they are of concern
- what health effects they may cause
- how they can be identified
- how they can be safely removed.

This section also covers the obligations of employers and others under Ontario's *Occupational Health and Safety Act*.

What are moulds?

Moulds are microorganisms that produce thousands of tiny particles called spores as part of their reproductive cycle. Mould colonies are usually visible as colourful, woolly growths. They can be virtually any colour – red, blue, brown, green, white, or black. When disturbed by air movement or handling, moulds release their spores into the air. Given the right environmental conditions, these spores can go on to form other mould colonies.

Where are moulds found?

Moulds can be found almost anywhere outdoors and indoors. Indoor moulds usually originate from outside sources such as soil and vegetation. Moulds love dark, moist environments and can grow at room temperature on various construction materials including wallpaper, particleboard, ceiling tiles, drywall, and plywood.

Construction workers can be exposed to toxic spores when working on buildings with some sort of water damage from flooding, plumbing leaks, or leaks in the structure itself.

Why are moulds of concern?

In buildings with water damage or ongoing moisture problems, certain types of “water-loving” moulds may reproduce to higher than normal levels and potentially cause adverse health effects. *Stachybotrys chartarum* (formerly known as *Stachybotrys atra*) is of particular concern because it can be found in large colonies and can cause adverse health effects.

Stachybotrys has gained special attention because it has been discovered in portable classrooms with ongoing moisture problems. It appears as small black patches and grows well on water-soaked cellulose material such as wallpaper, ceiling tiles, drywall, and insulation containing paper.

In addition to *Stachybotrys*, construction personnel working in water-damaged buildings may be exposed to other types of toxic moulds such as *Fusarium*, *Aspergillus*, and *Penicillium*.

What health effects can moulds cause?

Air movement and the handling of contaminated material can release toxic spores into the atmosphere. These spores cause adverse health effects by producing toxic substances known as mycotoxins. Once released, toxic spores must come into contact with the skin or be inhaled

before symptoms can develop. Not all exposed construction workers will develop symptoms.

- Exposure to toxic moulds may irritate skin, eyes, nose, and throat, resulting in allergy-like symptoms such as difficulty in breathing, runny nose, and watery eyes.
- Other symptoms such as fatigue and headache have also been reported.
- Workers who are allergic to moulds could experience asthmatic attacks.
- Workers exposed to *Stachybotrys* have also experienced burning in the nose, nose bleeds, severe coughing, and impairment of the immune system. *Stachybotrys* does not cause infection and is not spread from person to person.
- People with weakened immune systems are particularly susceptible to mould-related illness and should not work in mould-contaminated areas.

How are moulds identified?

Owners of buildings that may be mould-contaminated should conduct, at their own expense, an assessment to determine whether or not the buildings are indeed contaminated. The assessment should include building inspection and analysis of bulk samples.

Mould on visible surfaces may be just the tip of the iceberg. Since they thrive in dark, moist environments, moulds may be hidden from view. Thorough inspections of water-damaged areas must be conducted. This involves looking into wall cavities, behind drywall, under carpets, and above ceiling tiles.

Not all moulds are toxic. The type of mould identified and the extent of the contamination will determine the precautions to be taken.

Bulk sampling and laboratory analysis are used to document the type of mould growing on surfaces. The procedure involves scraping surface material into a sealable plastic bag and sending it by overnight delivery to an accredited laboratory.

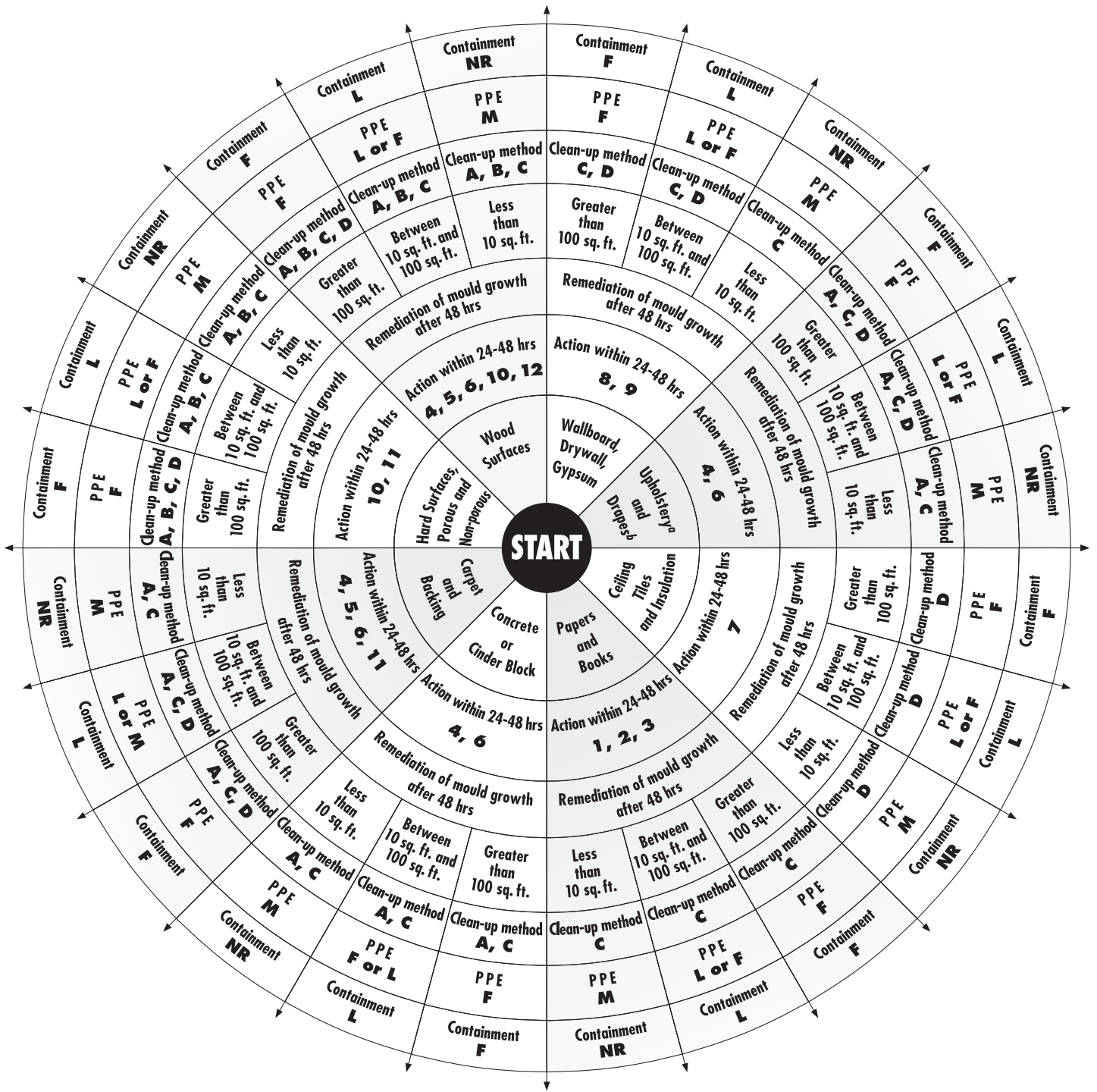
An accredited laboratory is one that participates in the American Industrial Hygiene Association's Environmental Microbiology Proficiency Analytical Testing Program. The chosen laboratory should have a competent mycologist (a person that studies moulds) who can analyze the sample and determine whether the mould is likely to pose a health risk.

Based on the presence of visible mould, evidence of water damage, and symptoms that are consistent with allergic or toxic response to mould, it may be justified to skip bulk sampling and go straight to remediation (removal).

The person taking bulk samples or performing inspections must be suitably protected for Level 1 work (see chart on the next page) and must be careful not to unduly disturb the mould.

How can moulds be safely removed?

Toxic moulds must be removed. However, special control measures must first be implemented to prevent worker exposure and the spread of moulds from the construction area to adjacent areas. This is especially true for



Stachybotrys because of its potentially severe health effects.

The extent of contamination governs what remediation measures need to be taken in order to prevent the spread of toxic moulds.

Note: The cause of moisture problems should be corrected before any mould remediation takes place.

A follow-up inspection should be conducted 3–6 months after remediation to ensure that the mould has not returned.

Obligations under the Act

Although there are no Ontario regulations specifically addressing moulds, an employer must, under the *Occupational Health and Safety Act*, take every precaution reasonable in the circumstances for the protection of a worker. Work practices set out by Health Canada in *Fungal Contamination of Public Buildings: A Guide to Recognition and Management* provide a reasonable standard.

Employers have a duty to instruct workers in the safe removal and handling of mould-contaminated material. Workers in turn have the duty to follow these instructions. Building owners must ensure that trade contractors follow proper remediation procedures.

Mould remediation chart

The chart on the opposite page summarizes mould control procedures recommended by the Environmental Protection Agency in the United States.

For various kinds of material, the chart indicates how mould growth can be prevented within 24–48 hours of water damage and also provides general advice on remediation. This information is intended only as a summary of basic procedures and is not intended, nor should it be used, as a detailed guide to mould remediation.

Although the chart may look complicated, it becomes clear and useful when taken one step, or one ring, at a time.

- 1) Start at the centre.
- 2) In the first ring, identify the material you are concerned about.
- 3) In the next ring, find out what actions to take within the first 24-48 hours of CLEAN water damage. Actions are numbered 1, 2, 3, 4 and so on. Each is spelled out under the **Action within 24–48 hrs** column at right.
- 4) Proceed to the next ring if mould growth is apparent and more than 48 hours have elapsed since water damage. Determine whether the contaminated area is less than 10 square feet, between 10 and 100 square feet, or greater than 100 square feet.
- 5) Proceed to the next ring and follow the clean-up method indicated for the size of the contaminated area. Methods are lettered A, B, C, and D. Each is spelled out under the **Clean-up Methods** column.
- 6) In the next ring, determine the level of personal protective equipment required. This is indicated by M, L, or F under the **PPE** column.
- 7) Finally, in the outermost ring, determine whether containment is necessary and, if so, whether it must be L (limited) or F (full). These requirements are explained in the **Containment** column.

Action within 24–48 hrs

Actions are for damage caused by clean water. If you know or suspect that water is contaminated by sewage or chemical or biological pollutants, consult a professional. Do not use fans unless the water is clean or sanitary. If mould has grown or materials have been wet for more than 48 hours, consult **Clean-up Method** in the chart.

1. Discard non-valuable items.
2. Photocopy valuable items, then discard.
3. Freeze (in frost-free freezer or meat locker) or freeze-dry.
4. Remove water with water-extraction vacuum.
5. Reduce humidity levels with dehumidifiers.
6. Accelerate drying process with fans and/or heaters.
 - Don't use heat to dry carpet.
 - Use caution applying heat to hardwood floors.
7. Discard and replace.
8. May be dried in place, if there is no swelling and the seams are intact. If not, then discard and replace.
9. Ventilate wall cavity.
10. For all treated or finished woods, porous (linoleum, ceramic tile, vinyl) and non-porous (metal, plastic) hard surfaces, vacuum or damp-wipe with water or water and mild detergent and allow to dry; scrub if necessary.
11. For porous flooring and carpets, make sure that subfloor is dry. If necessary clean and dry subfloor material according to chart.
12. Wet paneling should be pried away from walls for drying.

Clean-up Methods

Methods are for damage caused by clean water. If you know or suspect that water is contaminated by sewage or chemical or biological pollutants, consult a professional. These are guidelines only. Other cleaning methods may be preferred by some professionals. Consult **Action within 24–48 hrs** in the chart if materials have been wet for less than 48 hours and mould growth is not apparent. If mould growth is not addressed promptly, some items may be damaged beyond repair. If necessary, consult a restoration specialist.

- A. Wet-vacuum the material. (In porous material, some mould spores/fragments will remain but will not grow if material is completely dried.) Steam cleaning may be an alternative for carpets and some upholstered furniture.
- B. Damp-wipe surfaces with water or with water and detergent solution (except wood – use wood floor cleaner); scrub as needed.
- C. Use a high-efficiency particulate air (HEPA) vacuum once the material has been thoroughly dried. Dispose of HEPA-vacuum contents in well-sealed plastic bags.
- D. Remove water-damaged materials and seal in plastic bags inside containment area, if there is one. Dispose of as normal waste. HEPA-vacuum area once it is dried.

PPE (Personal Protective Equipment)

Use professional judgment to determine PPE for each situation, particularly as the size of the remediation site and the potential for exposure and health effects increase. Be prepared to raise PPE requirements if contamination is more extensive than expected.

- M Minimum – Gloves, N-95 respirator, goggles/eye protection.
- L Limited – Gloves, N-95 respirator or half-face respirator with HEPA filter, disposable overalls, goggles/eye protection.
- F Full – Gloves, disposable full-body clothing, head gear, foot coverings, full-face respirator with HEPA filter.

Containment

Use professional judgment to determine containment for each situation, particularly as the size of the remediation site, and the potential for exposure and health effects, increase.

- NR None Required
- L Limited – From floor to ceiling, enclose affected area in polyethylene sheeting with slit entry and covering flap. Maintain area under negative pressure with HEPA-filtered fan. Block supply and return air vents in containment area.
- F Full – Use two layers of fire-retardant polyethylene sheeting with one airlock chamber. Maintain area under negative pressure with HEPA-filtered fan exhausted outside of building. Block supply and return air vents in containment area.

Endnotes

- a) Upholstery may be difficult to dry within 48 hours. For items with monetary or sentimental value, consult a restoration specialist.
- b) Follow manufacturer's laundering instructions.

Equipment

10 PERSONAL PROTECTIVE EQUIPMENT

INTRODUCTION

Personal protective equipment (PPE) is something all construction workers have in common.

PPE is designed to protect against safety and/or health hazards. Hard hats, safety glasses, and safety boots, for instance, are designed to prevent or reduce the severity of injury if an accident occurs.

Other PPE, such as hearing and respiratory protection, is designed to prevent illnesses and unwanted health effects.

It is important to remember that PPE only provides protection. It reduces the risk but does not eliminate the hazard.

This manual's chapters on particular kinds of PPE will enable users to

- assess hazards and select a suitable control method
- locate and interpret legislation related to PPE
- effectively use and maintain PPE.

Legal Requirements

While common to all trades, PPE varies according to individual, job, and site conditions.

Legal requirements for personal protective equipment also vary and the appropriate sections of the construction regulation (O. Reg. 213/91) under the *Occupational Health and Safety Act* should be consulted.

The *Occupational Health and Safety Act* makes employers and supervisors responsible for ensuring that required PPE is worn. This does not mean that the employer must provide PPE but only ensure that it is provided by someone.

Workers, meanwhile, have a duty under the Act to wear or use PPE required by the employer. This addresses situations where the regulations may not require PPE but the employer has set additional health and safety standards, such as mandatory eye protection.

The construction regulation (O. Reg. 213/91) broadly requires that such protective clothing, equipment, or devices be worn "as are necessary to protect the worker against the hazards to which the worker may be exposed." It also requires that the worker be trained in the use and care of this equipment.

Control Strategies

Personal protective equipment should be the last resort in defence. Better alternatives lie in engineering controls that eliminate as much of the risk as possible. Engineering controls fall into five categories:

- substitution
- alternative work methods
- isolation
- enclosure
- ventilation.

Substitution

This control substitutes a less toxic chemical that can do the same job. A common example is the substitution of calcium silicate or fibreglass insulation for asbestos insulation. Substitution is an effective control as long as the substitute is less hazardous.

Alternative Work Methods

This simply means doing the job in a way which is less hazardous. For example, brushing or rolling paint produces much lower vapour levels than spray painting. Similarly, wet removal of asbestos releases up to 100 times less dust than dry removal. The change should be checked to ensure that it is safer.

Isolation

Isolation isolates the worker from the hazard. In a quarry, for example, the operator of a crusher can be isolated from dust by a filtered, air-conditioned cab.

Enclosure

A substance or procedure may be enclosed to contain toxic emissions. It may be as simple as putting a lid on an open solvent tank or enclosing asbestos removal projects with polyethylene sheeting (Figure 1). Enclosures

have also been built around compressors to reduce the noise level. Enclosures must not restrict access when maintenance is required.

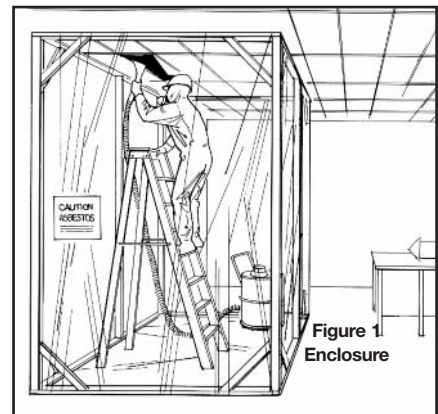


Figure 1
Enclosure

Ventilation

A common engineering control

is to dilute the contaminant in the air by using general ventilation. Local ventilation is better because it removes the contaminant. General ventilation may employ fans to move large volumes of air and increase air exchange. This is not suitable, however, for highly toxic materials.

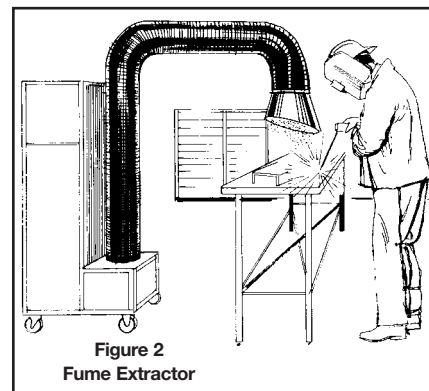


Figure 2
Fume Extractor

Local ventilation captures and removes contaminants at their source. At a shop bench, a fume hood can be constructed to remove dusts and fumes. On sites, portable fume extractors (Figure 2) can be used.

Remember: many filtering systems can only remove fumes—not gases or vapours.

Personal Protective Equipment

When it is not possible to apply any of the five engineering controls, personal protective equipment may be the last resort.

Regulations often refer to Canadian Standards Association (CSA) or other equipment standards as a convenient way to identify equipment which meets requirements and is acceptable. CSA-certified equipment can be identified by the CSA logo. For instance, there are CSA standards for



- Head Protection - CSAZ94.1M1992
- Eye Protection - CSAZ94.3-07
- Foot Protection - CSAZ195-M1992

For respiratory protection, National Institute for Occupational Safety and Health (NIOSH) standards and approvals are usually referenced throughout North America.

For life jackets, Transport Canada certification is the standard reference.

See the following chapters on particular kinds of PPE.

11 EYE PROTECTION

With the permission of the Canadian Standards Association, some information in this chapter is reproduced from CSA Standard CAN/CSA-Z94.3-07, Industrial Eye and Face Protectors, which is copyrighted by Canadian Standards Association, 178 Rexdale Boulevard, Toronto, Ontario M9W 1R3. While use of this material has been authorized, CSA shall not be responsible for the manner in which the information is presented, nor for any interpretations thereof.

Introduction

Eye protection is not the total answer to preventing eye injuries. Education regarding proper tools, work procedures, hazard awareness, and the limitations of eye protection is also very important. Like any other manufactured product, eye protection has material, engineering, and design limitations. But proper eye protection, selected to match the specific construction hazard, combined with safe work procedures, can help to minimize the number and severity of eye injuries.

When we consider that one out of every two construction workers may suffer a serious eye injury during their career, the importance of wearing proper eye protection cannot be over-emphasized. In the hazardous environment of the construction industry, wearing proper eye protection should be considered a labour-management policy, not a matter of individual preference.

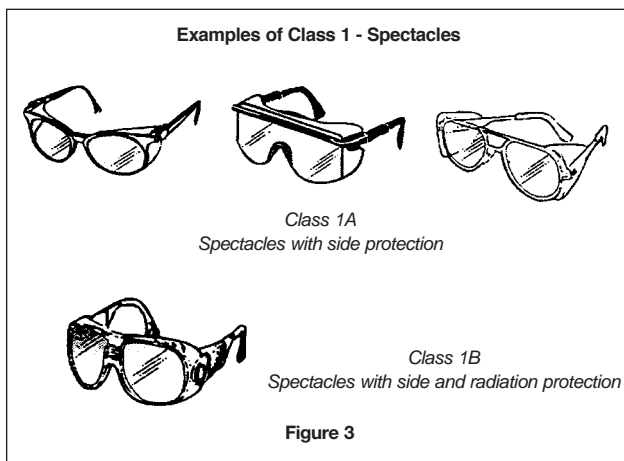
Classes of Eye Protectors

Before outlining the type(s) of eye protectors recommended for a particular work hazard, it is necessary to explain the various types of eye protectors available. Eye protectors are designed to provide protection against three types of hazards — impact, splash, and radiation (visible and invisible light rays) — and, for purposes of this manual, are grouped into seven classifications based on the CSA Standard Z94.3-07, *Industrial Eye and Face Protectors*.

The seven basic classes of eye protectors are: spectacles, goggles, welding helmets, welding hand shields, hoods, face shields, and respirator facepieces.

Class 1 – Spectacles (Figure 3)

CSA Standard Z94.3-07 requires that Class 1 spectacles incorporate side protection. Most side shields are permanently attached to the eyewear, but some may be detachable.

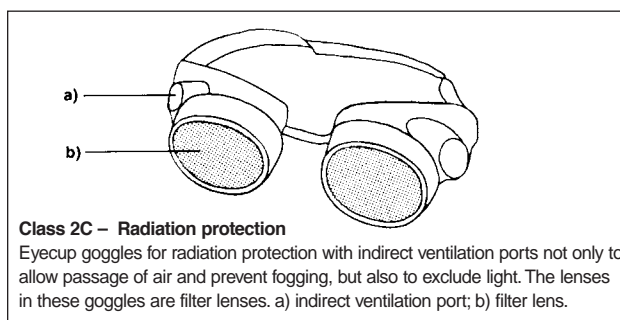
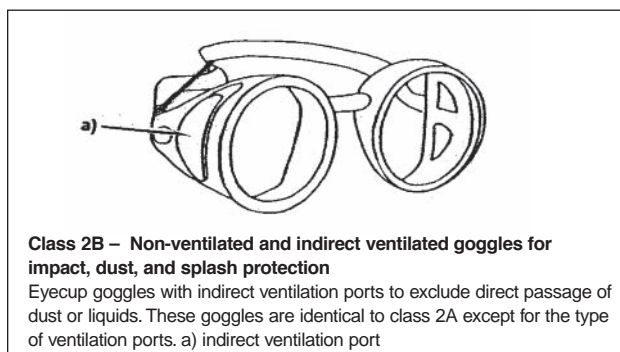
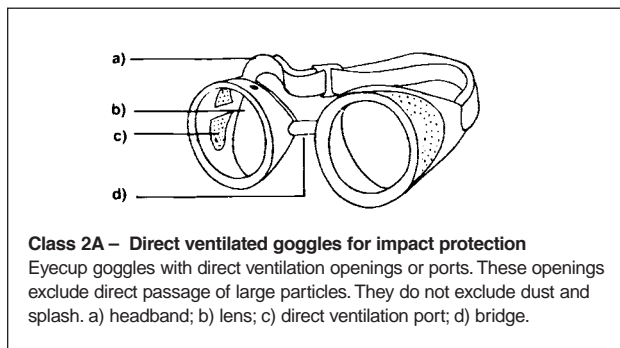


Class 2 – Goggles

There are two types of goggles — eyecup and cover. Both must meet the CSA Z94.3-07 Standard.

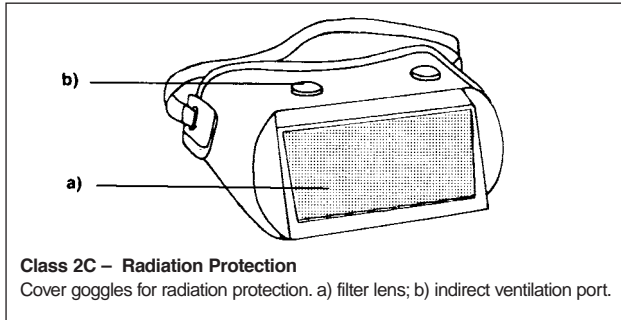
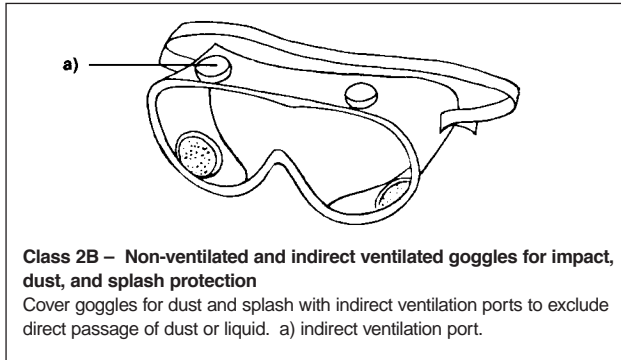
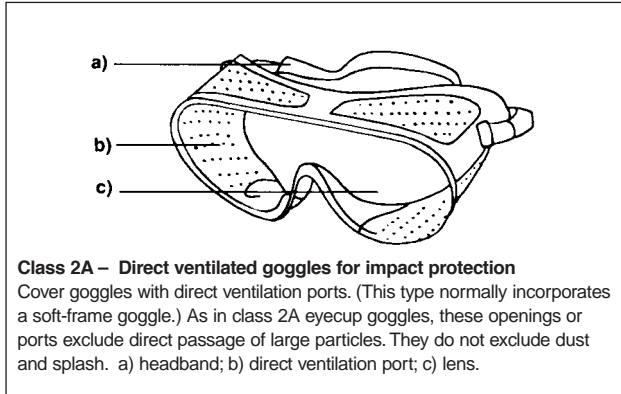
Eyecup goggles (Figure 4) completely cover the eye socket to give all-round protection. They have adjustable or elasticized headbands and are equipped with ventilation ports to allow passage of air and prevent fogging. Some have direct ventilation ports which prevent the direct passage of large particles, but do not exclude dust or liquids. Others have indirect ventilation ports which prevent the passage of particles, dust, and liquids. There are also models available with an adjustable chain bridge.

Figure 4 – Eyecup Goggles



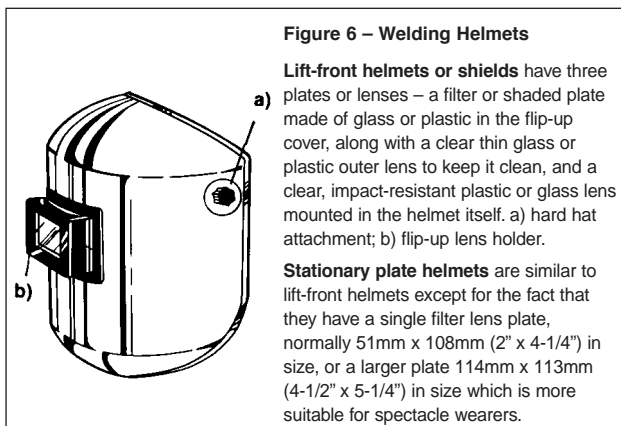
Cover goggles (Figure 5, below) are designed to be worn over spectacles. They have adjustable or elasticized headbands and are equipped with direct or indirect ventilation ports to allow passage of air and prevent fogging.

Figure 5 – Cover Goggles



Class 3 – Welding Helmets (Figure 6)

This class provides radiation and impact protection for face and eyes. There are two types of welding helmets available — the stationary plate helmet and the lift-front or flip-up plate helmet. There are also special models incorporating earmuff sound arrestors and air purification systems. Special magnifying lens plates manufactured to fixed powers are available for workers requiring corrective lenses.



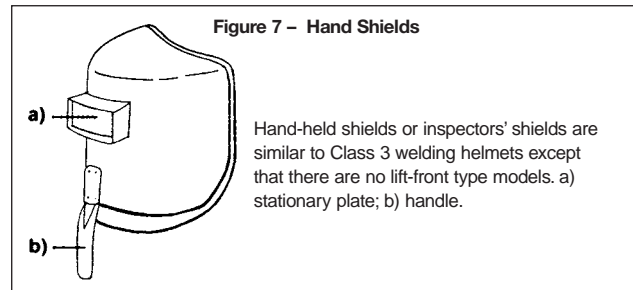
The filter or shaded plate is the radiation barrier. Arc welding produces both visible light intensity and invisible ultraviolet and infra-red radiation. These ultraviolet rays are the same type of invisible rays that cause skin burning and eye damage from overexposure to the sun. However, ultraviolet rays from arc welding are considerably more severe because of the closeness of the eyes to the arc and lack of atmospheric protection. In arc welding, therefore, it is necessary to use a filter plate of the proper lens shade number to act as a barrier to these dangerous light rays and to reduce them to the required safe degree of intensity. For proper welding shade numbers, see Table 2.

In addition to common green filters, many special filters are also available. Some improve visibility by reducing yellow or red flare; others make the colour judgment of temperature easier. A special gold coating on the filter lens provides additional protection by reflecting radiation.

Class 4 – Welding Hand Shields (Figure 7)

Welding hand shields are designed to give radiation and impact protection for the face and eyes.

NOTE: With welding helmets and hand shields, the user is continually lifting and lowering the visor. To protect the eyes when the visor is lifted, Class 1 spectacles should be worn underneath.

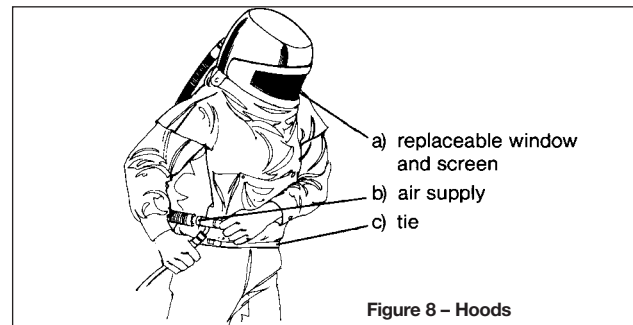


Class 5 – Hoods (Figure 8)

Non-rigid helmets or hoods come with impact-resistant windows usually made of plastic. An air-supply system may also be incorporated. Hoods may be made of non-rigid material for use in confined spaces and of collapsible construction for convenience in carrying and storing.

Hood types include

- 5A with impact-resistant window
- 5B for dust, splash, and abrasive materials protection
- 5C with radiation protection
- 5D for high-heat applications.



Class 6 – Face Shields (Figure 9)

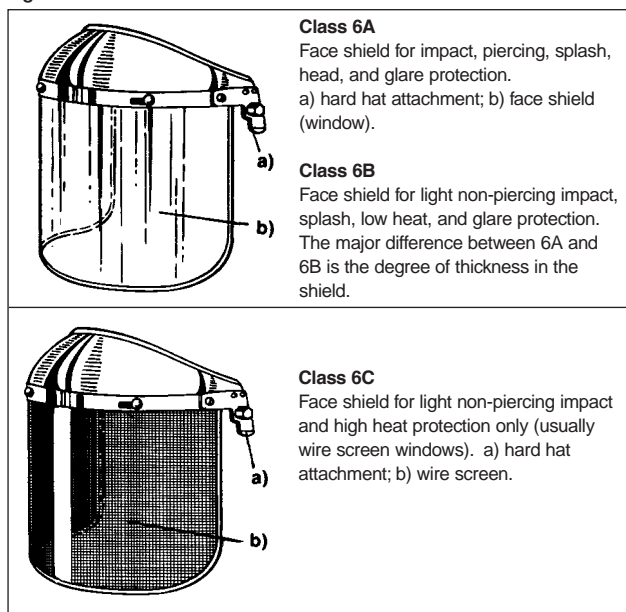
Face shields are just what the name implies—a device that includes a transparent window or visor to shield the face and eyes from impact, splash, heat, or glare. With face shields, as with welding helmets and hand shields, the user is continually lifting and lowering the visor. To protect the eyes when the visor is lifted, Class 1 spectacles should be worn underneath. Face shields may also be equipped with an adjustable spark deflector or brow guard that fits on the worker's hard hat. Shaded windows are also available to provide various degrees of glare reduction; however, they do not meet the requirements of CSA Standard Z94.3-07 *Industrial Eye and Face Protectors* for ultraviolet and total heat protection and should not be used in situations where any hazard is present from ultraviolet or infra-red radiation.

Class 6

This class includes

- 6A for impact and splash protection
- 6B for radiation protection
- 6C for high-heat applications.

Figure 9 – Face Shields



Class 6A
Face shield for impact, piercing, splash, head, and glare protection. a) hard hat attachment; b) face shield (window).

Class 6B
Face shield for light non-piercing impact, splash, low heat, and glare protection. The major difference between 6A and 6B is the degree of thickness in the shield.

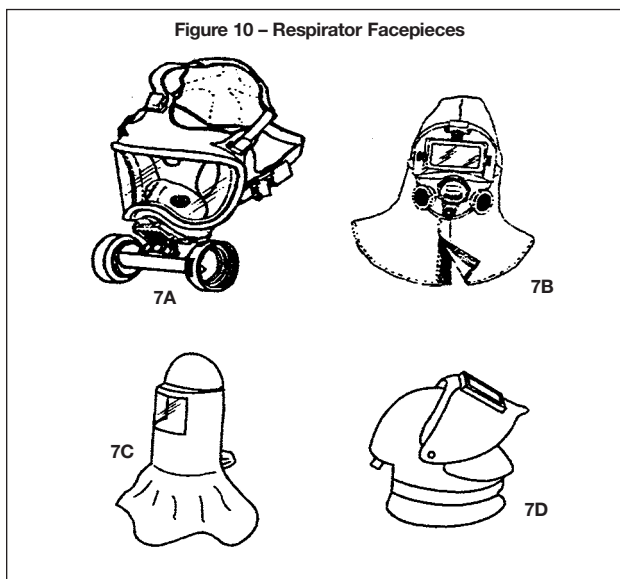
Class 6C
Face shield for light non-piercing impact and high heat protection only (usually wire screen windows). a) hard hat attachment; b) wire screen.

Class 7 – Respirator Facepieces (Figure 10)

This class includes

- 7A for impact and splash protection
- 7B for radiation protection
- 7C with loose-fitting hoods or helmets
- 7D with loose-fitting hoods or helmets for radiation protection.

Figure 10 – Respirator Facepieces



Hazards and Recommended Protectors

Reprinted from CSA Standard Z94.3-07 *Industrial Eye and Face Protectors*, Table 1 classifies the main eye hazards and outlines the types of protectors recommended for each. Each situation requires that all hazards be considered in selecting the appropriate protector or combination of protectors.

The practice of requiring all personnel to wear spectacles is strongly recommended. Spectacles should be worn underneath Classes 3, 4, 5, 6, or 7 protectors, where the hazard necessitates the use of spectacles.

The following classifications provide a general overview of eye protectors for each hazard group. For specific hazards, refer to Table 1. Note that the best eye protection results from a combination of different classes of eye protectors.

Group A: Flying Objects (Figure 11)

Minimum eye protection recommended:
Class 1 spectacles

Optimum eye protection recommended:
Goggles worn with face shields to provide eye and face protection.

Group B: Flying Particles, Dust, Wind, etc. (Figure 12)

Minimum eye protection recommended:
Class 1 spectacles

Optimum eye protection recommended:
Goggles (for dust and splash) worn with face shields to provide eye and face protection.

Group C: Heat, Glare, Sparks, and Splash from Molten Metal (Figure 13)

Minimum eye protection recommended:
Class 1 spectacles with filter lenses for radiation protection. Side shields must have filtering capability equal to or greater than the front lenses.

Optimum eye protection recommended:
Eyecup or cover goggles with filter lenses for radiation protection, worn with face shields to provide eye and face protection.

**Table 1
Hazards and Recommended Protectors**

Hazard groups	Nature of hazard	Hazardous activities involving but not limited to	Spectacles Class 1		Goggles Class 2			Welding helmet Class 3	Welding hand shield Class 4	Face shields Class 6			Non-rigid hoods Class 5				
			A	B	A	B	C			A	B	C	A	B	C	D	
A	Flying objects	Chipping, scaling, stonework, drilling; grinding, buffing, polishing, etc.; hammer mills, crushing; heavy sawing, planing; wire and strip handling; hammering, unpacking, nailing; punch press, lathework, etc.															
B	Flying particles, dust, wind, etc.	Woodworking, sanding; light metal working and machining; exposure to dust and wind; resistance welding (no radiation exposure); sand, cement, aggregate handling; painting; concrete work, plastering; material batching and mixing															
C	Heat, sparks, and splash from molten materials	Babbiting, casting, pouring molten metal; brazing, soldering; spot welding, stud welding; hot dipping operations															
D	Acid splash; chemical burns	Acid and alkali handling; degreasing, pickling and plating operations; glass breakage; chemical spray; liquid bitumen handling															
E	Abrasive blasting materials	Sand blasting; shot blasting; shotcreting															
F	Glare, stray light (where reduction of visible radiation is required)	Reflection, bright sun and lights; reflected welding flash; photographic copying															
G	Injurious optical radiation (where moderate reduction of optical radiation is required)	Torch cutting, welding, brazing, furnace work; metal pouring, spot welding, photographic copying															
H	Injurious optical radiation (where large reduction of optical radiation is required)	Electric arc welding; heavy gas cutting; plasma spraying and cutting; inert gas shielded arc welding; atomic hydrogen welding															

Note: Shaded areas are recommendations for protectors. Class 1 and Class 2 protectors shall be used in conjunction with recommendations for Class 3, 4, 5, and 6 protectors. The possibility of multiple and simultaneous exposure to a variety of hazards shall be considered in assessing the needed protection. Adequate protection against the highest level of each of the hazards should be provided. This Table cannot encompass all of the various hazards that may be encountered. In each particular situation, thorough consideration should be given to the severity of all the hazards in selecting the appropriate protector or combination of protectors. The practice of wearing protective spectacles (Class 1B) with filter lenses under welding helmets or hand shields is strongly recommended to ensure impact and flash protection to the wearer when the helmet or lift front is raised or the shield is not in use. Protectors that meet the requirements for ignition and flame resistance are not intended to provide protection in environments that expose the user to open flames or high-energy arcs. Courtesy Canadian Standards Association

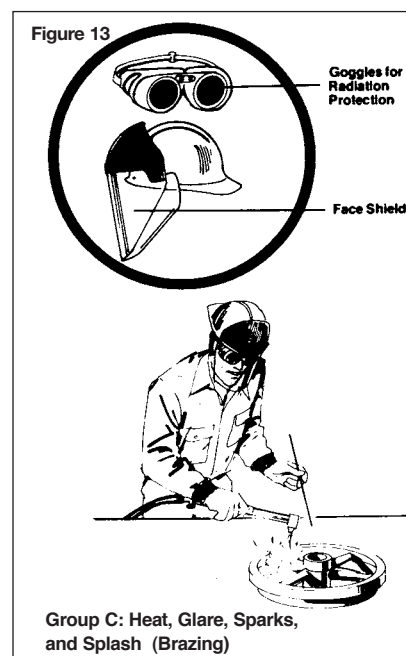
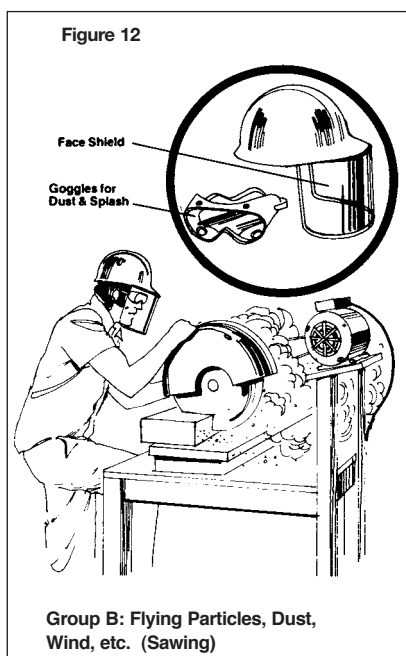
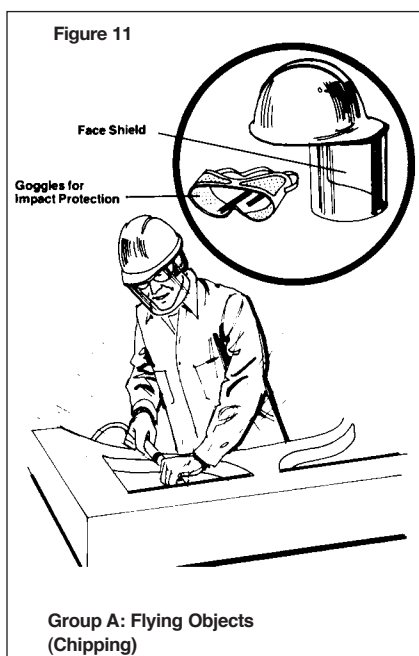
Table 2
Recommended Shade Numbers for Arc Welding and Cutting

Operation	Current in amperes																						
	0.5	1.0	2.5	5.0	10	15	20	30	40	60	80	100	125	150	175	200	225	250	275	300	350	400	450
SMAW (covered electrodes)					7				8				10				11						
GMAW (MIG)					7				10				10				10						
GTAW (TIG)					8				8				10										
Air carbon arc cutting	10																						
Plasma arc cutting									8				9				10						
Plasma arc welding	6				8				10				11										

Notes:

- (1) For other welding processes (e.g., laser, electron beam welding), consult the manufacturer for eye protection recommendations.
- (2) For pulsed GMAW (MIG), use peak current for selecting the appropriate shade number.
- (3) For underwater welding, the minimum shade number shown may not necessarily apply.

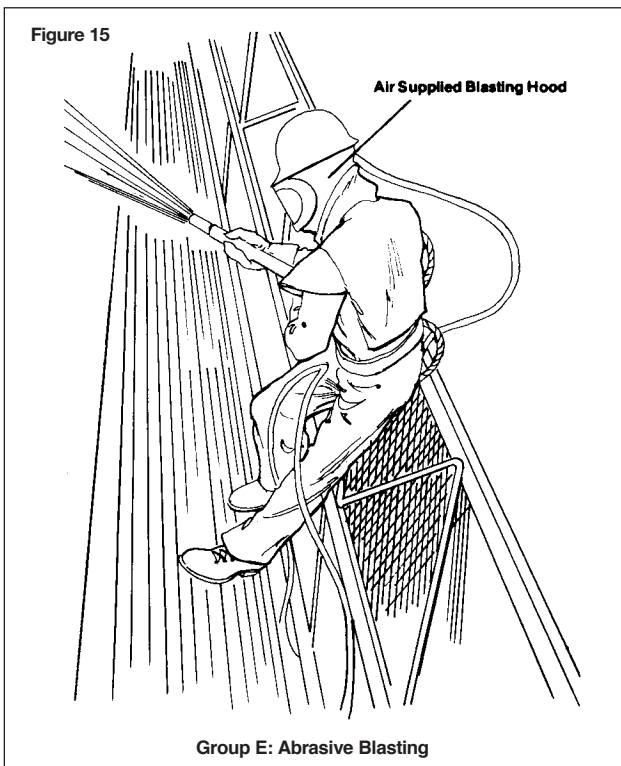
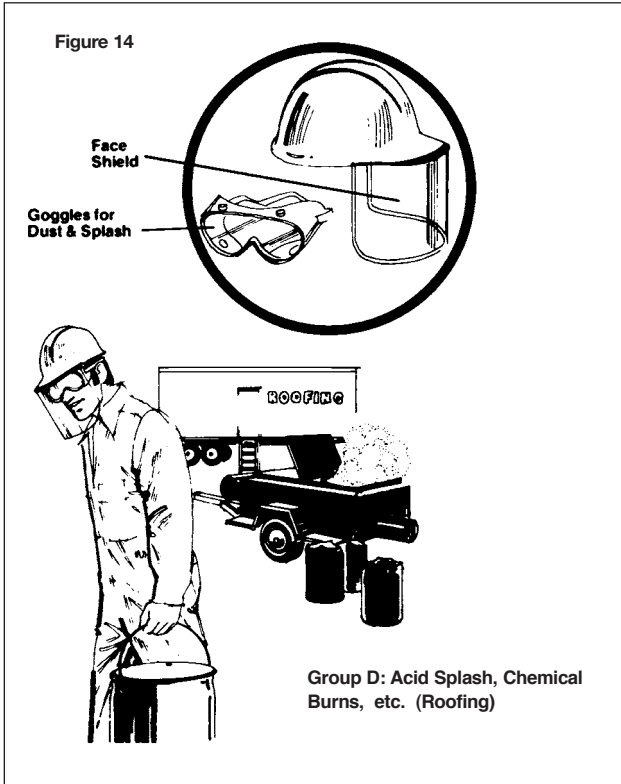
Courtesy Canadian Standards Association



Group D: Acid Splash, Chemical Burns, etc. (Figure 14)

Only eye protection recommended:
 Eyecup or cover goggles (for dust and splash) worn with face shields to provide eye and face protection.

Hoods may also be required for certain hazardous activities such as chemical spraying.



Group E: Abrasive Blasting Materials (Figure 15)

Minimum eye protection recommended:
 Eyecup or cover goggles for dust and splash.

Optimum eye protection recommended:
 Hoods with an air line.

Group F: Glare, Stray Light (Figure 16)

These are situations where only slight reduction of visible light is required, e.g., against reflected welding flash. Stray light would result from passing by a welding operation and receiving a flash from the side without looking directly at the operation.

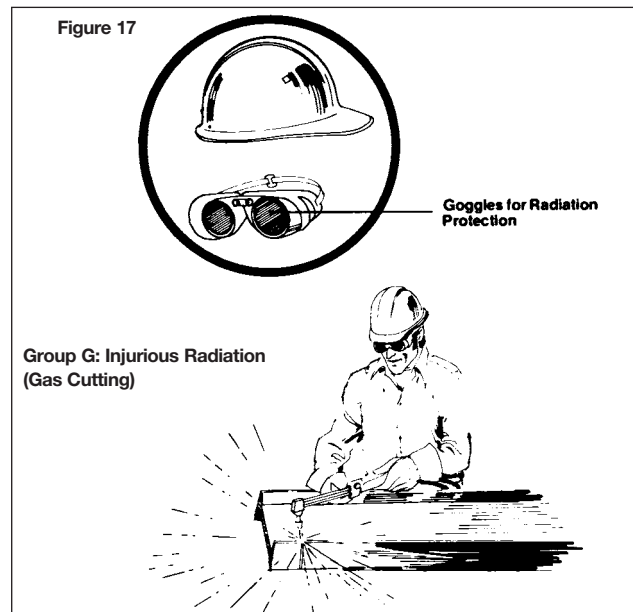
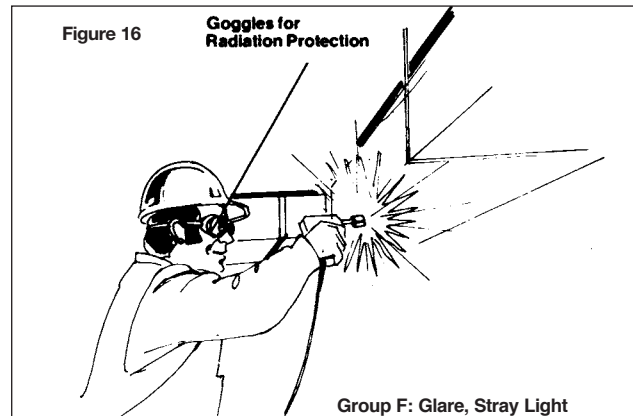
Minimum eye protection recommended:
 Filter lenses for radiation protection. Side shields must have filtering capability equal to or greater than the front lenses.

Optimum eye protection recommended:
 Goggles with filter lenses for radiation protection. See Table 2 for recommended shade numbers.

Group G: Injurious Radiation (Figure 17)

These are situations where only moderate reduction of visible light is required: for example, gas welding. Injurious radiation would result from looking directly at the welding operation.

Only eye protection recommended:
 Goggles with filter lenses for radiation protection.



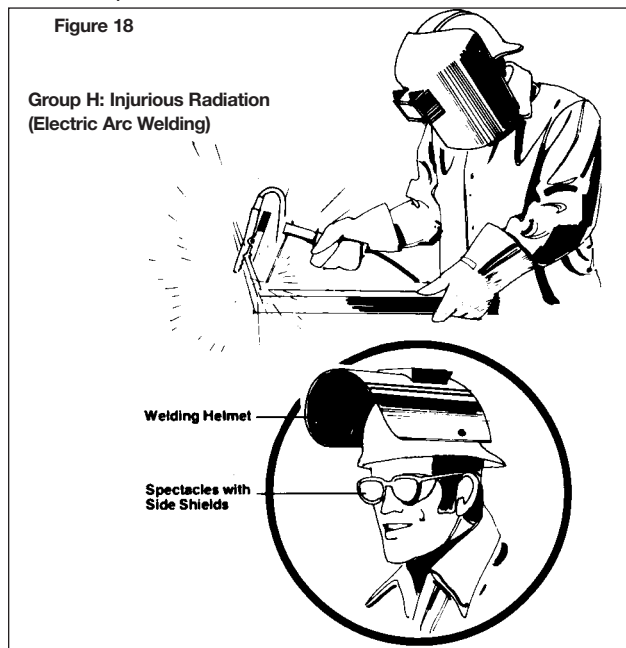
Note: The intensity of the flame and arc is lower in Group G than in Group H. For this reason, required filter shade numbers for this group are also lower. See Table 2.

Group H: Injurious Radiation (Figure 18)

These are situations where a large reduction in visible light is essential, e.g., in electric arc welding.

Only eye protection recommended:

Class 1 spectacles worn with full welding helmets or welding hand shields. These spectacles should incorporate suitable filter lenses if additional protection is required when the welding helmet is in the raised position: for example, when working near other welding operations. See Table 2.



Injuries Associated with Construction Hazards

The cornea is the front layer of the eye and the first point at which light enters the eye; if light rays cannot pass through the cornea, vision is prevented. Injuries to the cornea that cause scarring, scratching, or inflammation can impair sight.

1. Flying Objects

A piece of metal can pierce the cornea and eyeball and possibly cause the loss of an eye.

2. Dust

Dust, sawdust, etc. can cause irritation resulting in a corneal ulcer which is a breakdown of corneal tissue causing a red, watery, or pussy eye.

3. Heat

Heat can burn and severely damage the cornea.

4. Acid Splash

Acid splash and chemicals can burn the cornea, conjunctiva (white coat on the eye), and eyelid and possibly cause loss of sight.

5. Abrasive

Sand can cause a corneal abrasion which can result in loss of sight.

6. Glare

Glare can make it difficult to see and can cause extreme fatigue to the eye.

7. Radiation

Ultraviolet light from a welding arc can damage the cornea.

Correct eye protection, when matched to the hazard, can prevent or reduce the degree of any eye injury. However, once an eye injury has occurred, it is critical that the injury, no matter how small, be given immediate attention and first aid.

Eye protection can only protect against injury if it is worn continuously on-site.

It is often the time when a worker removes eye protection while working near or passing by other hazardous activities on the job that an eye injury results. When it is necessary to remove eye protection, do so only in a location that is completely away from hazardous work areas.

The inconvenience of wearing eye protection is far outweighed by the risk of being blinded in one or both eyes.

Purchase of Protective Spectacles

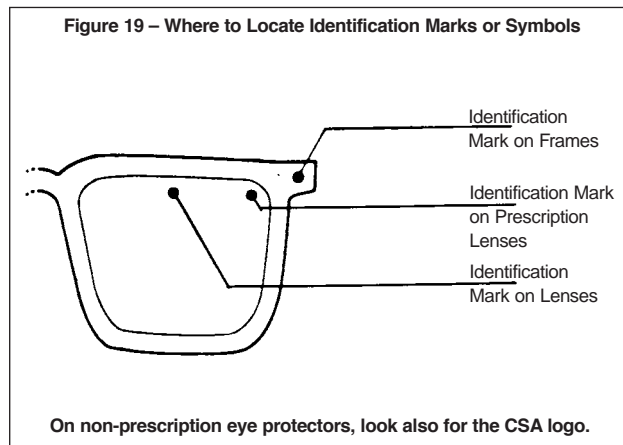
Protective spectacles are available with “plano” or non-prescription lenses and with prescription lenses.

The polycarbonate materials used in safety glasses provide the best protection, while regular plastic CR-39 lenses in industrial thickness provide a substitute where polycarbonate is not available. Anti-scratch coatings are applied to the lens surface to extend useful lens life.

Glass lenses, even when thermally or chemically hardened, are not acceptable for the workplace. Current glass lenses do not meet the impact requirements of CSA Standard Z94.3-07.

When purchasing safety glasses, specify **industrial protection** lenses and frames. This term indicates that the eye protection meets specific test requirements.

Industrial protection safety glasses can be identified by the manufacturer’s or supplier’s logo or monogram which is located on the lens and frame (Figure 19).



This mark must appear on both the frame **and** the lens. It distinguishes industrial quality lenses and frames from streetwear lenses and frames.

The Canadian Standards Association (CSA) certification program for non-prescription (plano) industrial eye and face protection covers complete protectors only. It does not cover separate components such as lenses, frames, or shields.

In addition to the manufacturer's logo or I.D. mark which appears on the eye protector, the CSA logo will appear to indicate the eye protection meets the requirements of the CSA Z94.3-07 standard. Certification of industrial prescription safety glasses is not yet available.



Until such a program is available, the user should look for the manufacturer's or supplier's logo or I.D. mark on the frame and lens which indicates adherence to the American National Standards Institute (ANSI) Standard Z87.1-1989.

Fitting

Improper fit is the most common reason for resistance to wearing eye protection. A worker who wears non-prescription (plano) lenses and continues to complain about blurred vision after the fit has been checked by a competent person may require prescription lenses. Prescription lenses must be fitted by an optician or optometrist. Plano eye protection should be fitted individually by a trained person.

Here are some general guidelines to follow when fitting the various classes of eye protectors.

Class 1 – Spectacles require that the proper eye size, bridge size, and temple length be measured for each individual. The wearer should be able to lower his head without the spectacles slipping.

Class 2 – Goggles with adjustable headbands should fit snugly over the wearer's spectacles when worn.

Class 3 – Welding helmets are equipped with adjustable attachments to provide a comfortable fit over the head and face. Attachments are also available to fit on hard hats.

Class 4 – Hand-held shields require no adjustment.

Class 5 – Hoods Adjustments are located on the top inside of the hood. A tie is located around the neck to secure the hood and to prevent the entry of dust.

Class 6 – Face shields are equipped with adjustable attachments to provide a comfortable fit over the head and face. Attachments are also available to fit on hard hats.

Class 7 – Respirator facepieces should fit snugly without gaps to make an effective seal against airborne contaminants.

Care

Eye protectors in construction are subjected to many damage-causing hazards. Therefore, care is very important.

1. Lenses should be inspected regularly for pitting and scratches that can impair visibility.

2. Scratched or pitted lenses and loose frames or temples should be replaced or repaired as soon as possible with components from the original manufacturer.
3. Lenses should be cleaned with clear water to remove abrasive dust—cleaning dry lenses can scratch the surface.
4. Anti-fog solutions can be used on glass or plastic lenses.
5. Frames should be handled with care and checked daily for cracks and scratches.
6. Eye protectors should never be thrown into tool boxes where they can become scratched or damaged.
7. Cases should be provided and used to protect spectacle lenses when not being worn.

Contact Lenses

In the construction industry, contact lenses are not a substitute for protective eyewear. Dust and dirt can get behind the contact lenses causing sudden discomfort and impairment of vision.

Contact lenses are also difficult to keep clean when they have to be removed or inserted since there are seldom suitable washing-up facilities on a jobsite.

It is recommended that contact lenses not be worn on construction sites.

However, in cases where contact lenses must be worn to correct certain eye defects, workers should obtain from their ophthalmologist or optometrist written permission indicating the necessity of wearing contact lenses in order to function safely at work. In these cases eye protection, preferably cover goggles, must be worn with the contact lenses.

12 HEAD PROTECTION

Standards

Requirements for head protection are specified in the current edition of the construction regulation (O. Reg. 213/91).

Under this regulation, hard hats are mandatory for all construction workers on the job in Ontario. The hard hat must protect the wearer's head against impact and against small flying or falling objects, and must be able to withstand an electrical contact equal to 20,000 volts phase to ground.

At the present time, the Ministry of Labour (MOL) considers the following classes of hard hats to be in compliance with the regulation.

Class B

- manufactured and tested in accordance with CSA Standard Z94.1-1977

Class B

- manufactured and tested in accordance with ANSI Z89.1-1986

Type I, Class E

- manufactured and tested in accordance with ANSI Z89.1-1997.

Class E

- manufactured and tested in accordance with CSA Standard Z94.1-1992

Type II, Class E

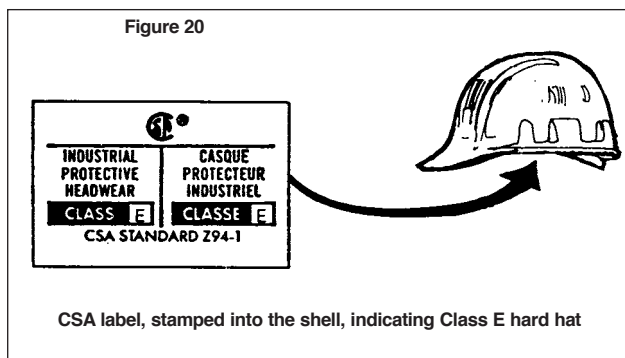
- manufactured and tested in accordance with ANSI Z89.1-1997.

"Type" and "Class" of hard hat can be identified by the CSA or ANSI label. Some manufacturers also stamp the CSA or ANSI classification into the shell of the hard hat under the brim.

Styles

New Class E hard hats come in three basic styles:

- 1) standard design with front brim, rain gutter, and attachment points for accessories such as hearing protection
- 2) standard design with front brim and attachment points for accessories but without a rain gutter
- 3) full-brim design with attachment points for accessories and brim that extends completely around the hat for greater protection from the sun.



13 FOOT PROTECTION

Ankle injuries represent 50% of all foot injuries in Ontario construction. Properly worn, a CSA-certified Grade 1 workboot meets the requirements of the current construction regulation (O. Reg. 213/91) and helps protect against ankle and other injuries.

One of three CSA grades, Grade 1 offers the highest protection and is the only one allowed in construction. In a Grade 1 boot, a steel toe protects against falling objects while a steel insole prevents punctures to the bottom of the foot.

Grade 1 boots can be identified by

- a green triangular patch imprinted with the CSA logo on the outside of the boot and
- a green label indicating Grade 1 protection on the inside of the boot.

Grade 1 boots are also available with metatarsal and dielectric protection. A white label with the Greek letter Omega in orange indicates protection against electric shock under dry conditions.



Selection and Fit

Grade 1 boots are available in various styles and sole materials for different types of work. For example, Grade 1 rubber boots may be better suited than leather boots for sewer and watermain or concrete work.

Boots should provide ample “toe room” (toes about 1/2 inch back from the front of steel box toe cap when standing with boots laced).

When fitting boots, allow for heavy work socks. If extra sock liners or special arch supports are to be worn in the boots, insert these when fitting boots.

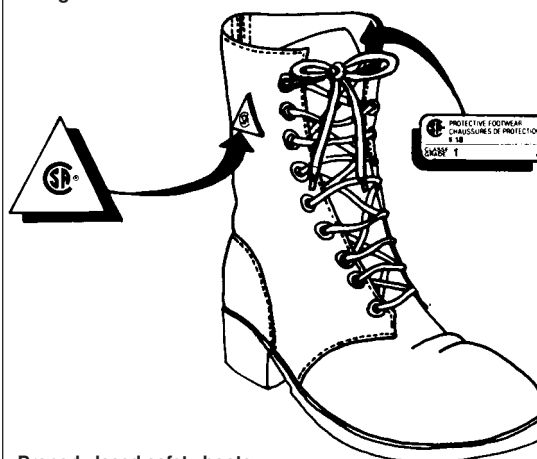
Care and Use

Lacing boots military style permits rapid removal. In an emergency, the surface lace points can be cut, quickly releasing the boot.

In winter, feet can be kept warm by wearing a pair of light socks covered by a pair of wool socks. Feet should be checked periodically for frostbite.

Use high-cut (260 mm or 9 in) or medium-cut (150 mm or 6 in) CSA Grade 1 workboots. The higher cut helps support the ankle and provides protection from cuts or punctures to the ankle.

Figure 21



Properly laced safety boots with CSA labels

14 HEARING PROTECTION

Introduction

Construction generally produces noise. Typical construction work may involve equipment driven by large and small engines, metal fabrication, power drilling and sawing, air hammering, and blasting — all of which can produce noise at harmful levels.

Depending on the noise level, duration of exposure, and other factors, a temporary or permanent hearing loss may result. Temporary hearing losses will usually be restored by the body within a few hours after the exposure has ceased. Hearing losses which cannot be restored by the body over any length of time are termed permanent.

A person suffering a hearing loss will frequently not realize it. Noise may be harmful at levels that an exposed person does not consider irritating or annoying. Therefore, despite **individual** preferences, prevention and control procedures must be based on the **general** potential for hearing loss.

Waiting for personal discomfort before taking preventive measures may be too late to avoid a permanent noise-induced hearing loss.

Noise Measurement

Measuring sound levels can determine

- whether or not a noise hazard is present

- noise exposures of workers
- which workers require hearing protection, hearing tests, education, and training.

Measurements are performed with a sound level meter (SLM). The unit used to measure the intensity of sound is the decibel (dB). Intensity is perceived as loudness.

Noise levels can't be added directly like other numbers. For example, two noise sources producing 90 dB each would have a combined output of 93 dB, not 180 dB. The combined output of 93 dB is actually a *doubling* of intensity.

In many construction situations several different sources each contribute to the overall noise. This means that a worker's exposure may be much higher than it would be if only one of the sources was present (Figure 22).

In addition to intensity, the SLM can detect a wide range of frequencies. Since the human ear tends to filter out the lower frequencies and slightly accentuate the higher ones, SLMs are engineered to do the same. They feature an internal mechanism called "A-weighting." The resulting noise level is expressed as decibels (dB) on the "A" scale or dBA.

Two types of noise measurements can be performed: area and personal.

An **area noise measurement** is taken in a specific work area. The measurement is generally used as a preliminary step to determine whether more detailed evaluation involving personal noise measurement is necessary. Area

noise readings should not be used to determine what hearing protection is required or who needs a hearing test. Personal exposure measurement should be used for these purposes.

Personal noise measurement involves a small device called a noise dosimeter. Workers can wear the device to determine their average noise exposure over a whole shift. Usually worn around the waist, the dosimeter has a microphone that is placed as close to the worker's ear as possible.

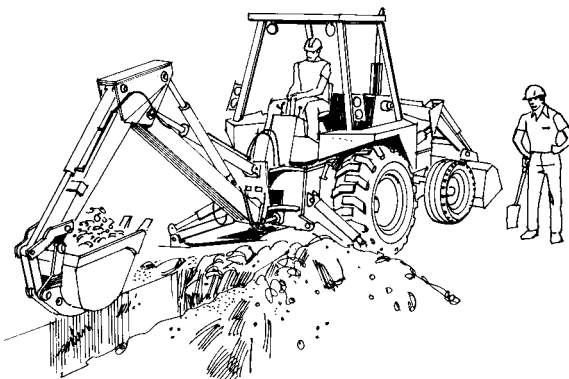
Noise measurements should be carried out in accordance with acceptable standards. Canadian Standards Association (CSA) Standard Z107, *Procedures for the Measurements of Occupational Noise Exposure*, provides guidance on the type of equipment to use, which workers to test, and how to test.

Noise evaluation must be done by a knowledgeable person trained and experienced in conducting noise surveys.

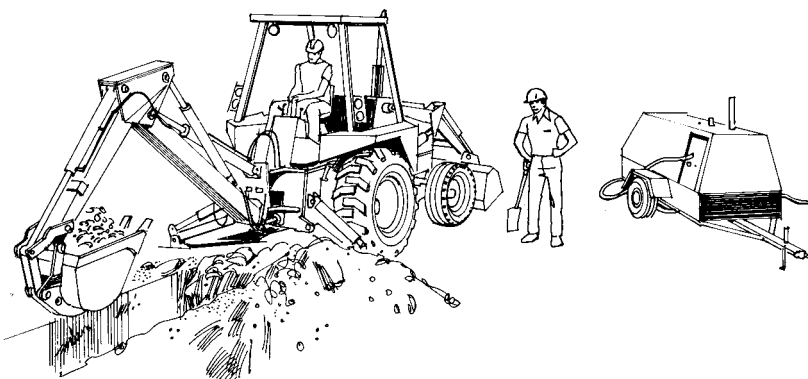
Hearing Process

The hearing process begins when the outer ear directs sound waves into the ear canal (Figure 23). The eardrum vibrates as sound waves strike it. This vibration is then transmitted through the middle ear where it is amplified on a membrane called the oval window. The oval window separates the middle ear from the inner

Figure 22



The backhoe is producing 90 dB of noise. The worker standing nearby is therefore exposed to 90 dB.



The backhoe is producing 90 dB. The compressor is also producing 90 dB. The worker standing between the two pieces of equipment is therefore exposed to their combined output. This double intensity is 93 dB.

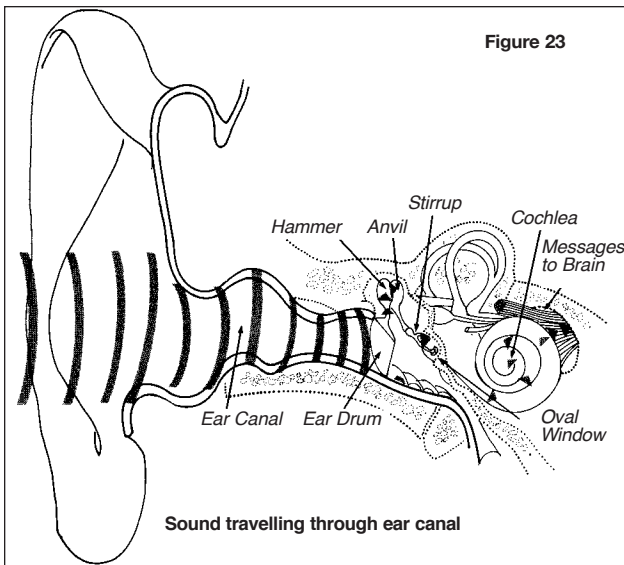


Figure 23

ear where the sensitive hearing organs are located. Attached to the other side of the oval window is a tiny, snail-shaped structure called the cochlea. The cochlea contains fluid and hair cells. These thousands of small but highly sensitive hair cells feel the vibration. Responding to the cells are microscopic nerve endings that send messages to the brain, where the signals are interpreted as varieties of sound.

Hearing Loss

Any reduction in the normal ability to hear is referred to as a loss of hearing. A hearing loss can be either temporary or permanent.

Temporary Threshold Shift

With a temporary hearing loss, normal hearing will usually return after a rest period away from all sources of intense or loud noise. The recovery period may be minutes, hours, a day or perhaps even longer. It is believed that a temporary hearing loss occurs when hair cells in the inner ear have been bent by vibrations and need time to bounce back.

Most of the temporary hearing loss occurs during the first two hours of exposure and recovery takes place usually within the first two hours after exposure stops. However, the length of time needed for recovery depends primarily on how great the initial loss was. The greater the initial loss the longer the time needed to recuperate. This temporary decrease in hearing ability is called a temporary threshold shift (TTS) because the threshold or level at which sound can be heard has been raised.

For instance, to listen to your favourite music at the volume you like, you would have to turn it up a few more notches than usual. This phenomenon explains why some people, particularly those who suffer from some form of hearing loss, claim that they “get used to the noise.”

If these previous exposures are allowed to continue under the same conditions and without the proper interval of rest, then a certain degree of permanent hearing loss is possible.

Permanent Threshold Shift

Permanent hearing loss is the result of hair cell or nerve destruction within the cochlea. Once these important parts

of the hearing process are destroyed, they can never be restored or regenerated. The resulting permanent hearing loss, also referred to as permanent threshold shift (PTS), can range from slight impairment to nearly total deafness.

A symptom of PTS is the inability to pick up sounds with higher frequencies. As damage increases, the reception of speech becomes more difficult.

Unfortunately, the damage builds up gradually. Workers may not notice changes from one day to another. But once the damage is done there is no cure. Effects may include the following.

- Sounds and speech become muffled so that it's hard to tell similar-sounding words apart or to pick out a voice in a crowd.
- Sufferers ask people to speak up, then complain that they are shouting.
- There's a permanent ringing in the ears (tinnitus).
- Sufferers need to turn the volume on the radio or television way up or find it hard to use the telephone.

Determining Factors

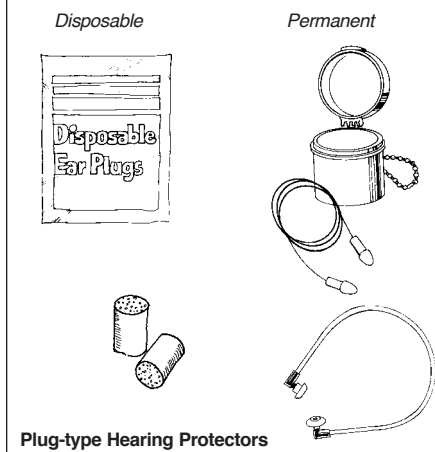
The following factors determine the degree and extent of hearing loss:

- **Type of Noise**
(continuous, intermittent, impact, high or low frequency)
- **Intensity of Noise**
(level of loudness)
- **Duration of Exposure**
(length of time worker subjected to noise — for example, during day, on specific shifts)
- **Employment Duration**
(years worker subjected to noise)
- **Type of Noise Environment**
(character of surroundings – for example, enclosed, open, reflective surfaces)
- **Source Distance(s)**
(distance of worker from noise source)
- **Worker's Position**
(position of worker relative to noise source)
- **Worker's Age**
(for instance, a 20-year-old apprentice versus a 50-year-old journeyman)
- **Individual Susceptibility**
(sensitivity difference, physical impairments)
- **Worker's Present Health**
(whether a worker has any detectable losses or ear diseases)
- **Worker's Home and Leisure Activities**
(exposures to noise other than occupational, such as hunting, skeet shooting, earphone music, snowmobiling, etc.)

Other prime causes of permanent hearing loss are age, traumatic injuries (such as from explosions or gunfire), and infection.

Noise, however, is the major identifiable cause of hearing loss. Therefore, it is important that controls are exercised wherever possible so that such losses can be prevented.

Figure 24



Hearing Protection

One form of controlling noise hazards is through the proper use of hearing protection devices (HPDs). Hearing protectors should be provided when engineering controls cannot be implemented or while such controls are being initiated.

Hearing protective devices are barriers that reduce the amount of noise reaching the sensitive inner ear. Fit, comfort, and sound reduction or “attenuation” are important considerations in choosing HPDs.

Commonly used hearing protection devices are either earplugs or earmuffs. Earplugs attenuate noise by plugging the ear canal (Figure 24). The muff-type protector is designed to cover the external part of the ear providing an “acoustical seal” (Figure 25). Table 1 describes some of the characteristics of these different types of hearing protectors.

Effectiveness

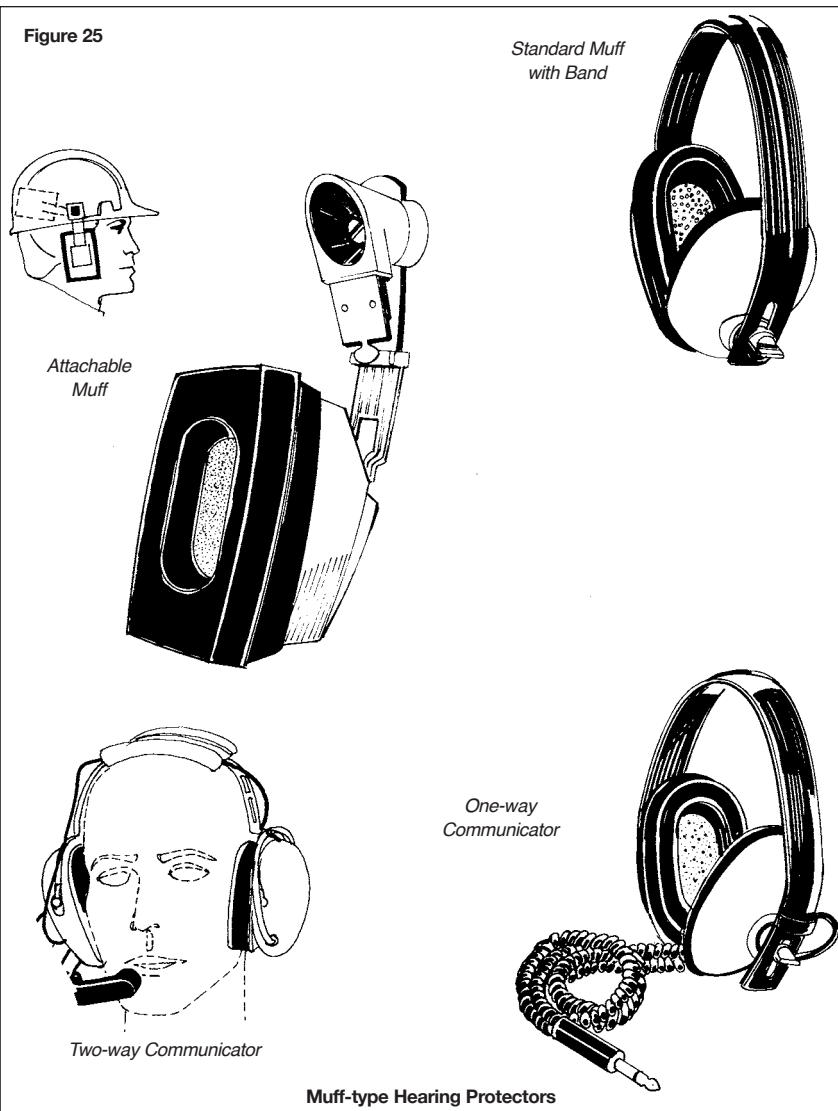
Obviously, the effectiveness of an HPD depends on the amount of time it is worn. What is not obvious to most wearers is the drastic reduction in protection if HPDs are not worn in noisy environments even for short periods of time.

The reduction in effectiveness can be as great as 95% or more if the protectors are not worn for as little as three or four minutes. It is therefore important to wear HPDs during the entire noise exposure period in order to achieve the maximum protection available.

The effectiveness of HPDs also depends on the manner in which noise is transmitted through or around the protector. The following points should be noted.

- Even relatively small openings or air leaks in the seal between the hearing protector and the skin can typically reduce attenuation by 5 to 15 dB or more.

Figure 25



- Constant movement of the head or body vibration can lead to air leaks, therefore making periodic adjustments necessary to ensure a proper seal.
- Hair, especially long hair and facial hair, can cause a poor fit.
- Proper fitting is crucial to obtaining a reasonable degree of protection from an HPD.
- Earmuff effectiveness is greatly influenced by headband tension. If tension decreases through routine usage or alteration by the user, earmuff effectiveness is reduced.
- Modifying the earmuff by drilling holes in the earcups renders the protection useless.
- Anatomical differences such as ear canal size, jaw size, and heads of different shape and size may affect the fit of earmuffs and earplugs. To accommodate these differences, HPDs should be made available to users in various shapes and sizes.
- Recreational headsets such as those used with radios and CD players are **not** to be used as hearing protection.

Table 3: Types of Hearing Protectors

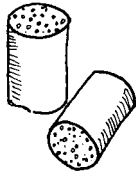
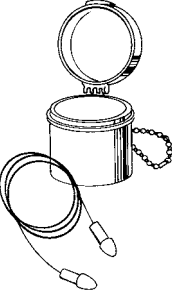


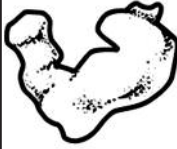

	FOAM EARPLUGS	PREMOULDED EARPLUGS	EARMUFFS	FORMABLE EARPLUGS	CUSTOM-MOULDED EARPLUGS	SEMI-INSERT EARPLUGS
						
STYLE and COMFORT	Consist of compressible plastic foam. Come in many shapes. Often described as “disposable plugs.” Elasticity lets them adapt easily to changes in ear canal.	Usually made of plastic or silicone rubber attached to a flexible stem for handling and insertion. Come in many shapes and sizes to suit different ear canals.	Consist of two insulated plastic cups attached to metal or plastic band. Cups equipped with soft cushions for seal and comfort. Head band tension ensures good seal.	Made from pliable material such as cotton/wax mixture, silicone putty, and mineral wool.	Custom made to fit a particular ear by taking an impression of the ear, making a mould, and casting a plug.	Commonly known as banded earplugs or canal caps. They consist of small caps or pods that are held in place over the ear canal by spring-loaded bands.
INTENDED USE	Most brands can be reused a few times before being discarded.	To be used more than once.	To be used regularly. Can be worn with or without plugs. Easily attached to hard hats.	<ul style="list-style-type: none"> • Single-use for mineral wool products. • Multi-use for cotton/wax products. • Semi-permanent for silicone putty products. 	Permanent use	To be used more than once.
HYGIENE PRACTICES	Clean hands required each time fresh plugs inserted.	Plugs should be cleaned regularly with warm soapy water, preferably after each removal from ear.	General maintenance required. Head band must be maintained. Cushions must be replaced when soiled or brittle.	Clean hands required for shaping and insertion.	Wash with hot water and soap, preferably after removal.	Wash with hot water and soap, preferably after removal.
ADVANTAGES	Low risk of irritation. One size fits most workers.	Reusable.	Less likely to cause irritation. When attached to hard hat, always available for use.	Relatively cheap	Good fit only if a proper impression of the ear is taken.	Good for when frequent removal is required.
DISADVANTAGES	Use requires clean hands. Large supply required for frequent removals and usage.	Plugs must be kept clean to prevent irritation. May produce some discomfort with pressure. Though reusable, plugs degrade over time. Inspect and replace as necessary.	Bands may wear out and tension decrease. Eyewear and hair may interfere with fit and reduce protection.	Not recommended for the noise levels found on construction projects.	If the wearer’s weight changes drastically, new plugs should be made. Plugs can be lost, shrink, harden, or crack over time, and must be replaced.	Proper seal is necessary for good attenuation.

Table 4

MAXIMUM NOISE LEVEL (dBA)	RECOMMENDED CLASS OF HEARING PROTECTOR
Less than 85 dBA	No protection required
Up to 89 dBA	Class C
Up to 95 dBA	Class B
Up to 105 dBA	Class A
Up to 110 dBA	Class A plug + Class A or Class B muff
More than 110 dBA	Class A plug + Class A or Class B muff and limited exposure

Recommended criteria for selecting a class of hearing protector, based on a daily 8-hour exposure to noise levels in dBA. Adapted from CSA Standard Z94.2-M1984.

Selection Criteria

In addition to attenuation characteristics, the following factors should be considered when selecting hearing protectors:

- noise exposure levels and standards
- comfort
- appearance
- communication requirements
- work environment or work procedures
- overprotection.

Noise Exposure Levels and Standards

Identifying the noise level(s) to which an individual may be exposed throughout an entire working day determines the class of hearing protector needed.

Evaluation is based on eight-hour noise exposure, not a spot or area measurement. For example, a quick-cut saw operated by a mason may produce a noise level of 110 dBA. But the mason may only be exposed to an average of 92 dBA over the full eight-hour shift. The reason is that the saw is not operated continuously during that period. There will be times when the worker is laying brick, taking a coffee break, or eating lunch.

CSA Standard Z94.2, *Hearing Protectors*, identifies classes of hearing protectors as A, B, and C. Protectors are classed by attenuation ability under laboratory conditions modified by certain practical field considerations. Class A protectors offer the highest ability to attenuate, followed by B and C.

Table 4 provides guidelines for proper selection. Table 5 lists typical noise levels for various kinds of construction equipment. The upper limits of the noise levels can be used as a guide in selecting a specific class of hearing protectors.

Comfort

Comfort is an important consideration in selection. An HPD that isn't comfortable will simply not be worn or will be worn improperly.

Table 5

TYPICAL NOISE LEVEL MEASUREMENTS FOR CONSTRUCTION	
* EQUIPMENT	NOISE LEVEL (dBA) AT OPERATOR'S POSITION
Cranes	78 – 103
Backhoes	85 – 104
Loaders	77 – 106
Dozers	86 – 106
Scrapers	97 – 112
Trenchers	95 – 99
+ Pile drivers	119 – 125
Compactors	90 – 112
Grinders	106 – 110
Chainsaws	100 – 115
Concrete saw	97 – 103
Sand blasting nozzle	111 – 117
Jackhammers	100 – 115
Compressors	85 – 104

* Generally, newer equipment is quieter than older equipment. (For noise levels of specific equipment, contact the Construction Safety Association of Ontario.)

+ Pile drivers and explosive-actuated tools generate intermittent or "impulse" sound.

With earplugs several factors affect comfort. Since some plugs are relatively non-porous they can often create a pressure build-up within the ear and cause discomfort. Dirty plugs may irritate the ear canal. The shape of an individual's ear canals may not allow certain plugs to fit properly.

Earmuffs should be made of materials which do not absorb sweat and which are easy to maintain and clean. The earmuff cup should be adjustable to conform to various head sizes and shapes. Headband tension and earcup pressure should be adjusted so that they are effective without being uncomfortable. Weight may also be a factor.

Workers should be allowed to try out various HPDs to determine which are most comfortable.

Appearance

HPD appearance may influence selection. Those that look bulky or uncomfortable may discourage potential users. Allowing workers to select from various HPDs, or various makes of the same HPD, can help overcome this problem.

Speech Requirements

Consider the level of the noise hazard and the risks of impaired communication (Table 6). The potential for speech interference is greatest when background noise — meaning all noises generated in the surrounding area — is low. In this case HPD wearers with impaired hearing may have difficulty understanding speech because they must contend not only with their hearing loss but with the attenuation of their protector as well. In other cases, the use of HPDs by workers with normal hearing may actually

Table 6

Effects of Hearing Protectors on Understanding Speech

HEARING ABILITY OF WEARER	BACKGROUND / SURROUNDING NOISE LEVELS IN dBA		
	Less than 75	75 to 85	Greater than 85
Normal hearing	Little effect	No effect	Improves communication
Impaired hearing	Moderate effect	Little effect	No effect

improve their understanding of speech in noisy environments.

In other words, wearing HPDs doesn't always reduce the ability to communicate. Factors to consider include the user's hearing ability, noise levels, and the type of HPD. Where two-way communication is vital, radio-equipped hearing protectors can be worn (Figure 25).

Work Environment/Procedures

Choosing an HPD is sometimes dictated by the constraints of the work area or work procedures. For example, large volume earmuffs may not be practical in confined work situations with little head room or clearance.

In this case, flat-cup muffs or earplugs may be more practical. Where work is necessary near electrical hazards, it may be desirable to use non-conductive suspension-type muffs. The type of protector may also be determined by the nature of work, as in welding where certain types of earmuffs may interfere with the welder's helmet.

The attenuation of the muff-type hearing protector may be considerably reduced when worn with spectacle-type safety glasses. (The head configuration of the wearer and the type of glasses worn will determine the reduction in attenuation.) Where safety glasses must be worn, cable-type temples should be used in order to allow the smallest possible opening between the seal of the protector and the head. Otherwise earplugs should be worn, provided they are adequate.

Consideration should be given to hearing protectors which can be attached to hard hats where exposures to noise may be high but intermittent and where hard hats must be worn at all times. Periodic adjustments may be necessary because movement of the hard hat may break the seal of the HPD.

Consideration should also be given to work involving oils, grease, and other products which may soil hands. Ear infections may occur when earplugs are inserted by soiled hands.

Overprotection

Workers wearing HPDs that provide too much attenuation may feel isolated from their surroundings. Sounds may be heard as muffled. Speech or warning sounds may be unrecognizable. Overprotection can lead workers to resist wearing HPDs. Protectors should be chosen to provide sufficient, but not excessive, attenuation. The objective should be to reduce noise levels to or below the recommended maximum eight-hour exposure of 85 dBA, but not below 70 dBA.

Fit, Care, and Use

Workers should be instructed in the proper fitting of HPDs as recommended by the manufacturer. Training should include a demonstration. Workers should then practice using the HPDs under close supervision. Checks are needed to ensure the best possible protection. Many of these checks relate to fit.

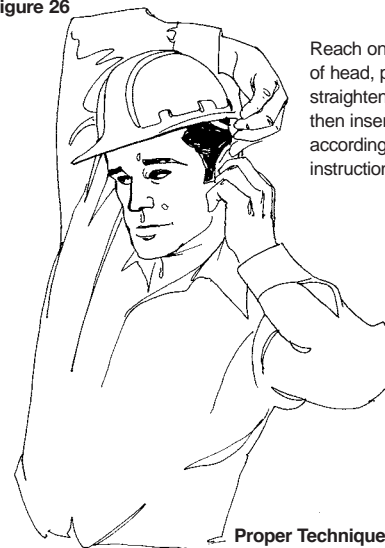
Earmuffs

- 1) Earmuffs should conform to the latest issue of CSA Standard Z94.2.
- 2) The cup part of the earmuff should fit snugly over the entire ear and be held firmly in place by a tension band.
- 3) The cup and band should not be so tight as to cause discomfort.
- 4) Cup, cushion, and band should be checked for possible defects such as cracks, holes, or leaking seals before each use of the HPD.
- 5) Because band tension can be reduced over a period of time, the band may require repair or replacement.
- 6) Defective or damaged parts should be repaired or replaced as needed. Tension band, cushions, and cups are readily replaceable.

Earplugs

- 1) Earplugs should conform to the latest issue of CSA Standard Z94.2.
- 2) For maximum attenuation the method of insertion illustrated in Figure 26 should be used. Because the ear canal is slightly S-shaped, the ear must be pulled back to straighten the canal for the plug to fit properly.
- 3) Earplugs must be fitted snugly in the ear canal. This will cause some discomfort initially. However, in time (usually a period of two weeks) the discomfort vanishes. Should there be severe discomfort initially or mild discomfort for more than a few weeks, seek professional advice. In most instances it will only be a matter of re-sizing, although some ear canals cannot be fitted with plugs because of obstructions, unique shapes, or deformities. In fact, the shape of one ear canal may be entirely different from the other.

Figure 26



Reach one hand around back of head, pull ear upwards to straighten S-shaped ear canal, then insert plug with other hand according to manufacturer's instructions.

Proper Technique for Inserting Earplugs

- 4) Reusable earplugs should be washed with warm soapy water daily to prevent the remote possibility of infection or other discomfort. When not in use, they should be kept in a clean container.
- 5) Earplugs with torn or otherwise damaged flanges should be replaced.

WARNING: Cotton batten does not provide adequate protection from construction noise.

Training

Workers who wear HPDs should be trained to fit, use, and maintain the protectors properly. Workers should understand

- that there is risk of hearing loss if HPDs are not worn in noisy environments (eight-hour exposure of 85 dBA)
- that wearing HPDs is required in all situations where noise exposure may damage hearing
- that to be effective an HPD must not be removed even for short periods
- that various HPDs are available to accommodate differences in ear canal size, jaw size, head size and shape, comfort level, compatibility with other forms of PPE, etc.
- that proper fit is essential to achieve maximum protection.

Audiometry

Anyone who works with noisy equipment on a regular basis should take a periodic audiometric or hearing capability test for the following reasons:

- 1) **To determine whether or not a hearing loss exists.** Even if no hearing loss is detected, workers exposed to noise levels in excess of 90 dBA should wear hearing protectors. Workers who have some hearing loss should wear HPDs to minimize any further loss.
- 2) **To determine the type of hearing loss.** Certain hearing losses can be reversed. Some individuals have suffered for years only to find out that their hearing problem could have been corrected surgically. These situations usually occur as a result of birth defects and are known as “conductive losses.”
- 3) **To determine the effectiveness of programs for noise control and hearing protection.** Early identification is important so that prevention practices can be implemented, maintained, and revised when necessary.

Summary

Control of noise in construction is of growing importance as a result of increasing hearing loss claims.

Most noise problems can be analyzed in terms of source, transmission path, and receiver. This allows a convenient understanding of the overall problem and a useful approach to remedial measures. The three components can usually be treated in isolation, although sometimes all three must be considered together in order to control unacceptable noise levels.

At source, remedial measures are aimed at reducing the noise being generated.

Along the transmission path, barriers can be introduced to reduce or eliminate noise reaching the ears.

For the receiver, remedial measures involve personal protective equipment properly selected, fitted, and worn. The equipment must be used in high noise environments **all the time.**

Failure to provide preventive or control measures will result in temporary and ultimately permanent hearing losses.

The Construction Safety Association of Ontario can assist management and labour in the industry by providing useful information, research, and training.

15 RESPIRATORY PROTECTION

Introduction

In the course of their work, construction personnel are often exposed to respiratory hazards in the form of dangerous dusts, gases, fumes, mists, and vapours.

In some cases careful selection of materials and work practices can virtually eliminate respiratory hazards. Where that is not possible, the next best choice is engineering controls such as fume exhaust systems that deal with the hazard at the source.

Respirators are the least preferred method of protection from respiratory hazards because they

- do not deal with the hazard at the source
- can be unreliable if not properly fitted and maintained
- may be uncomfortable to wear.

In spite of these drawbacks, in many construction operations respiratory protective equipment is the only practical control.

Respiratory Hazards

Respiratory hazards may be present as

- gases
- vapours
- fumes
- mist
- dusts.

Gases — consist of individual molecules of substances, and at room temperature and pressure, they are always in the gaseous state. Common toxic gases found in construction are carbon monoxide from engine exhaust and hydrogen sulphide produced by decaying matter found in sewers and other places.

Vapours — are similar to gases except that they are formed by the evaporation of liquids (e.g., water vapour). Common vapours found in construction are produced by solvents such as xylene, toluene, and mineral spirits used in paints, coatings, and degreasers.

Fumes — are quite different from gases or vapours, although the terms are often used interchangeably. Technically, fumes consist of small particles formed by the condensation of materials which have been subjected to high temperatures. Welding fume is the most common type of fume in construction. Other examples include pitch fume from coal tar used in built-up roofing and fume from diesel engines.

Mists — are small droplets of liquid suspended in air. The spraying of paint, form oils, and other materials generates mists of varying composition.

Dusts — are particles which are usually many times larger than fume particles. Dusts are generated by crushing, grinding, sanding, or cutting and by work such as demolition. Two kinds of hazardous dust common in construction are fibrous dust from insulation materials (such as asbestos, mineral wool, and glass fibre) and non-fibrous silica dust from sandblasting, concrete cutting, or rock drilling.

In construction settings, respiratory hazards may be compounded, depending on the number and variety of

jobs under way. For example, both mist and vapours may be present from paint spraying or both gases and fumes from welding.

Health Effects

Respiratory hazards can be divided into the following classes based on the type of effects they cause.

Irritants are materials that irritate the eyes, nose, throat, or lungs. This group includes fibreglass dust, hydrogen chloride gas, ozone, and many solvent vapours. With some materials (e.g., cadmium fume produced by welding or oxyacetylene cutting of metals coated with cadmium) the irritation leads to a pneumonia-like condition called pulmonary edema. **This effect may not be apparent until several hours after exposure has stopped.**

Asphyxiants are substances which result in inadequate oxygen in the body. They can be classified as either **simple asphyxiants** or **chemical asphyxiants**.

Simple asphyxiants are other gases or vapours which cause oxygen to be displaced, creating an **oxygen-deficient atmosphere**. Oxygen content of 18% may lead to some fatigue during exertion. Oxygen concentrations lower than 15% can cause loss of consciousness and may be fatal. For example, nitrogen used to purge tanks can displace oxygen, resulting in unconsciousness and even death for those who enter. Oxygen may also be consumed by chemical or biological activity such as rusting or bacteria digesting sewage.

Chemical asphyxiants interfere with the body's ability to transport or use oxygen. Two examples are carbon monoxide and hydrogen sulphide.

Central nervous system depressants interfere with nerve function and cause symptoms such as headache, drowsiness, nausea, and fatigue. Most solvents are central nervous system depressants.

Fibrotic materials cause "fibrosis" or scarring of lung tissue in the air sacs. Common fibrotic materials found in construction include asbestos and silica.

Carcinogens cause or promote cancer in specific body organs. Asbestos is the most common carcinogen in construction.

Nuisance dusts do not cause significant effects unless exposure is of high concentration and/or long duration. Excessive exposure to these substances can be adverse in itself or can aggravate existing conditions such as emphysema, asthma, or bronchitis. Examples include plaster dust, cellulose from some insulation, and limestone dust.

Respiratory Protective Equipment

A wide variety of equipment can be used to protect workers from respiratory hazards. Devices range from simple, inexpensive dust masks to sophisticated self-contained breathing apparatus. Generally, the equipment can be divided into two distinct classes — air-purifying respirators and supplied-air respirators.

Air-Purifying Respirators

As their name indicates, these devices purify the air drawn through them. There are two main types of air-purifying respirators:

1) Non-powered

Air is drawn through the air-purifying filter by the wearer breathing in and creating a negative pressure in the facepiece. Non-powered respirators depend entirely on the wearer breathing in (inhaling) and breathing out (exhaling) to deliver an adequate supply of purified breathing air.

2) Powered

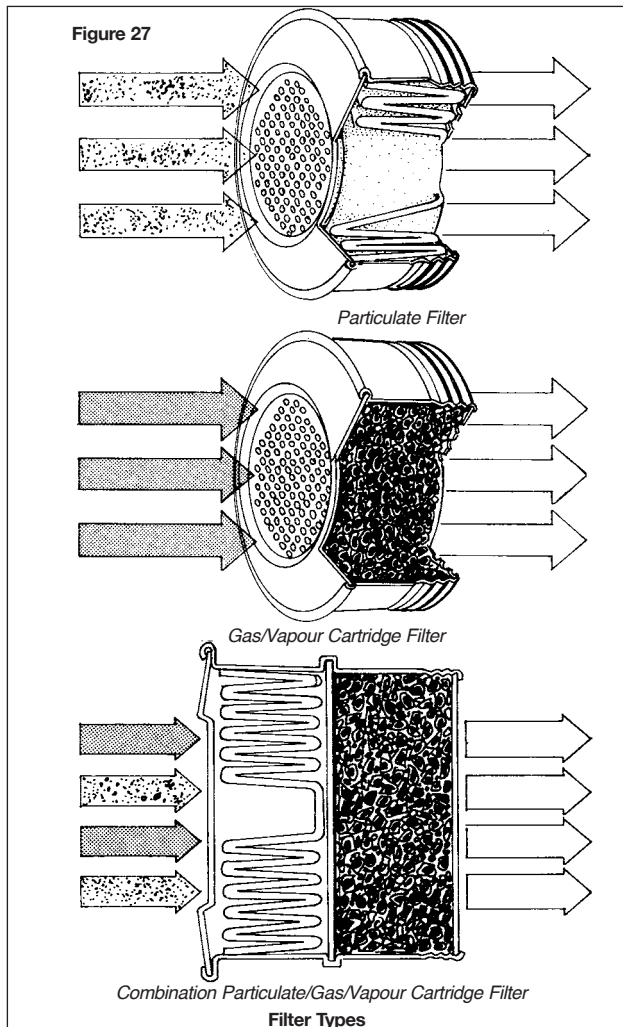
These respirators have a blower that blows purified air into the facepiece. (Figure 31).

Air-purifying respirators have limitations and should not be used where

- there is insufficient oxygen
- very high concentrations of contaminant are present
- the contaminant cannot be detected by odour or taste at safe levels.

Warning: Air-purifying respirators simply remove certain airborne hazards. They do not increase or replenish the oxygen content of the air and should never be worn in atmospheres containing less than 19.5% oxygen.

Although many different filters have been designed for specific hazards, there are three basic types used with air-purifying respirators:



- particulate filters
- gas/vapour cartridge filters
- combination particulate/gas/vapour filters. See Figure 27.

Particulate Filter

This type removes solid particles such as dusts, fumes, or mists and operates like the air filter in a car engine. The devices may be filtering facepiece respirators or respirators with replaceable filters. Different grades of filters are available, depending on the size of particles to be removed.

When particulate filters fill up with dust or fume, they become harder to breathe through but are more efficient, since air is being filtered through the layer of trapped particles as well as the filter itself.

While particulate filters can provide good protection against particles such as dusts, mists, or fumes, they cannot filter out gases or vapours because of the very small size of gas and vapour molecules.

Particulate filters for non-powered air-purifying respirators are divided into three levels of filter efficiency: 95%, 99%, and 99.97%. These numbers refer to the percentage of particles the filter can remove, based on the particle size most difficult to trap. Filters rated to these efficiencies outperform the dust/mist and dust/fume/mist filters of the past. For workers removing asbestos insulation or lead paint, for instance, the 99.97% efficiency cartridge would be the best choice. This is known as the 100 efficiency class, previously identified as the HEPA filter.

Oil has been found to ruin the filtering ability of some filter material. Oil coats the filter fibres, preventing the electrostatic charge on the fibres from attracting and removing particulates. Therefore, to ensure that a suitable filter is being used, particulate filters have an N, R, or P designation:

- N – Not resistant to oil
- R – Resistant to oil
- P – oil-Proof.

The N series of filters is suitable for airborne particles such as wood dust, when there are no oil-based particles also in the air. For example, an N series filter would be recommended during the removal of old lead paint. However, when spraying form oil or putting down hot asphalt—operations that involve airborne oil particles—the correct filter would have an R or P designation.

The R series—resistant to oil—should only be used for a single shift when solvent or oil mist is present in the air. This filter resists oil but may lose its filtering ability when in contact with oil over a long time.

When using P series filters, check the manufacturer's instructions to determine how long the filter can be used when airborne oil particles are present. P series filters were originally thought to be oil-proof but tests show there may be some loss of filtering ability with long-term oil exposure.

Warning: N, R, and P series filters by themselves do not provide protection against organic vapours.

Gas/Vapour Cartridge Filter

This type uses substances which absorb or neutralize gases and vapours. Unlike particulate filters, gas/vapour cartridge filters become less efficient the longer they are used. They act like sponges and, when full, allow gas or vapour to pass through without being absorbed. This is called “breakthrough.”

Common gas/vapour cartridge filters include the following:

- “Organic Vapour Cartridges” usually contain activated charcoal to remove vapours such as toluene, xylene, and mineral spirits found in paints, adhesives, and cleaners.
- “Acid Gas Cartridges” contain materials which absorb acids and may be used for protection against limited concentrations of hydrogen chloride, sulphur dioxide, and chlorine.
- “Ammonia Cartridges” contain an absorbent designed specifically to remove only ammonia gases.

Note

For respirators equipped with gas or vapour cartridges to be used safely, the contaminant must have good warning properties (odour, taste, or breathing irritation) that let the user know the cartridge is no longer working. When the user senses contaminant starting to penetrate the cartridge, it's time to change the cartridge.

When users depend on odour as a warning, the odour threshold of the contaminant must be below its exposure limit.

Certain cartridges are available with an end-of-service-life indicator. These cartridges have been developed for a few contaminants with poor warning properties. The end-of-service-life indicator changes colour to warn the user to change the cartridge.

Cartridges must not be used for contaminants with poor warning properties unless the respirator manufacturer can offer cartridges with end-of-service-life indicators.

Combination Particulate/Gas/Vapour Cartridge with Filter

This type removes particulate matter, vapours, and gases from the air. It is used where more than one type of hazard is present or may develop.

Supplied-Air Respirators

Supplied-air respirators provide clean breathing air from an uncontaminated source, usually a special compressor located in a clean environment, or from cylinders containing compressed breathing air. The quality of the air supplied should meet the requirements of CSA Standard Z180.1, *Compressed Breathing Air and Systems*.

The moisture content of supplied air should be limited to prevent fogging, corrosion, and freezing of regulators and valves and to prolong the service life of filters used to remove other contaminants.

The “pressure dew point” is important in relation to moisture. The term refers to the temperature at which

moisture in compressed air, at a given pressure, will condense out as droplets or “dew.” It must be kept at least 5°C below the lowest expected ambient temperature.

For example, if you are working where the temperature is -10°C, the dew point should be at least -15°C. Water vapour can be removed from compressed air with a drying system or water-absorbing materials.

Types of Supplied-Air Respirators

The three basic types of supplied-air respirators are airline unit, ambient air blower, and self-contained breathing apparatus (SCBA).

The **airline unit** depends on a hose connecting the respirator to cylinders of compressed breathing air. An abrasive-blasters hood is one example (Figure 28).

The **ambient air blower** draws air through an inlet hose (positioned where the air is clean) and pumps the air under fairly low pressure to the worker's hood, helmet, or facepiece.

The **self-contained breathing apparatus** (SCBA) uses a cylinder of air carried by the wearer (Figure 29). SCBAs are awkward, heavy, and require frequent cylinder changes.

Combination airline/SCBA units are available for work in confined spaces and other high-risk assignments where reserve protection is required (Figure 30).

With these devices or with simple airline units, the wearer's mobility is understandably restricted by the trailing hose and the length of line available. In addition, airlines may get crimped or may snag on equipment.

If an atmosphere is immediately dangerous to life or health, a combination airline/SCBA unit is required.

Both airline and SCBA units are more expensive than air-purifying systems, but they generally provide much greater protection.

Modes of Operation

Respirators can operate in the following modes:

- “negative pressure” or “demand”
- “constant-flow”
- “positive pressure” or “pressure-demand.”

Negative Pressure or Demand Mode

Air is delivered only when the wearer inhales. Pressure inside the facepiece is then lower than pressure outside the facepiece. This allows air to pass through the filters in the case of air-purifying respirators, or actuates a valve that allows air into the facepiece in the case of supplied-air respirators. Because contaminated air may leak inward around the facepiece, these devices have limited use in high exposure conditions.

Constant-Flow Mode

As the name implies, these devices deliver a constant flow of air to the wearer. Powered air-purifying respirators (PAPRs) use a battery-powered fan to draw air through the filter and then blow it into the facepiece (Figure 31). Constant-flow supplied-air respirators such as sandblasters' hoods use a simple valve to control the flow of “clean” air from the compressor. Minimum flow rates of 170 litres per minute (6 cubic ft/min) for loose-fitting hoods

or helmets and 115 litres per minute (4 cubic ft/min) for tight-fitting facepieces must be maintained to minimize inward leakage of contaminated air and still provide adequate breathing air.

Positive Pressure or Pressure-Demand Mode

Since the previous modes may permit significant inward leakage, a system which maintains a positive pressure inside the facepiece at all times, as well as supplying more air as demanded, was developed.

If leakage occurs, the high pressure inside the facepiece directs the leakage away from the facepiece rather than allowing it in.

This class of device is only available with supplied-air respirators.

Styles of Facepieces

In addition to the type of respirator and mode of operation, the style of facepiece is used to classify respirators. Different styles are available (Figure 32).

Protection Factors

The protection factor (PF) is a measure of the effectiveness of a respirator. PFs are determined by dividing the concentration of a contaminant outside the respirator by the concentration inside the respirator. PFs are used in the selection process to determine the maximum use concentration (MUC) for the respirator. The MUC is determined by multiplying the legislated or recommended exposure limit by the PF.

For example, the exposure limit for chrysotile asbestos in Ontario is 0.1 fibre/cm³ of air. If we are using a half-mask respirator with N100 filters (PF=10), the MUC is 1 fibre/cm³. This is obtained by multiplying the PF (10) by

the exposure limit (0.1 fibre/cm³). If the concentration of asbestos becomes greater than 1 fibre/cm³ during the course of work, a respirator with a greater protection factor must be used.

The Canadian Standards Association (CSA), the US National Institute for Occupational Safety and Health (NIOSH), and the American National Standards Institute (ANSI) have each published slightly different protection factors. In this manual, NIOSH-assigned protection factors are used.

The degree of protection depends on the type of respirator, style of facepiece, and principle of operation.

Generally, supplied-air respirators provide better protection than air-purifying respirators; full-face masks provide better protection than half-face masks; and positive-pressure devices provide more protection than negative-pressure types.

Table 7 lists protection factors for the respirators described so far. The information can be used to select the most appropriate device for any given situation.

The protection factors listed in Table 7 were determined by testing a wide variety of devices worn by a large number of people and represent the average degree of protection achieved. Protection factors for individual wearers may differ significantly from the values listed.

Respirator Selection

In order to select the proper respirator for a particular job, it is necessary to know and understand

- the characteristics of the contaminant(s)
- the anticipated exposure conditions
- the performance limitations of the equipment
- any legislation that applies.

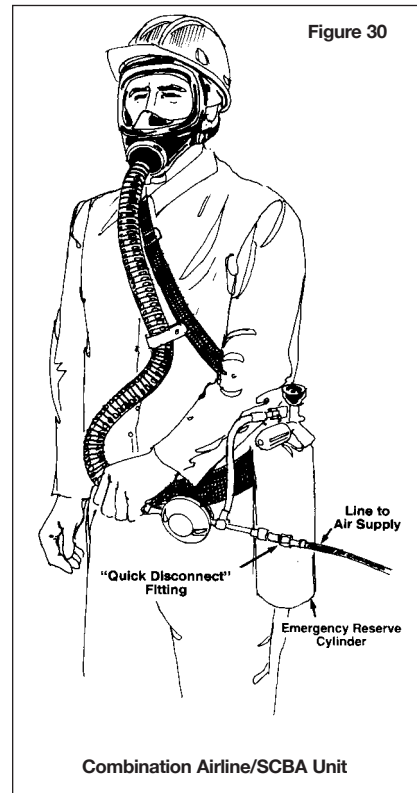
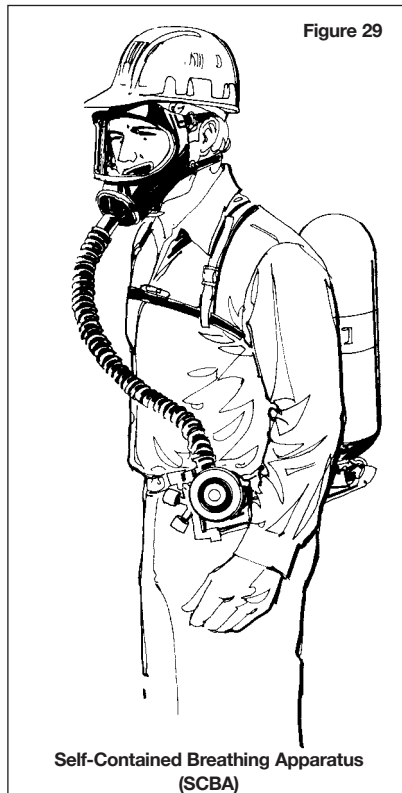
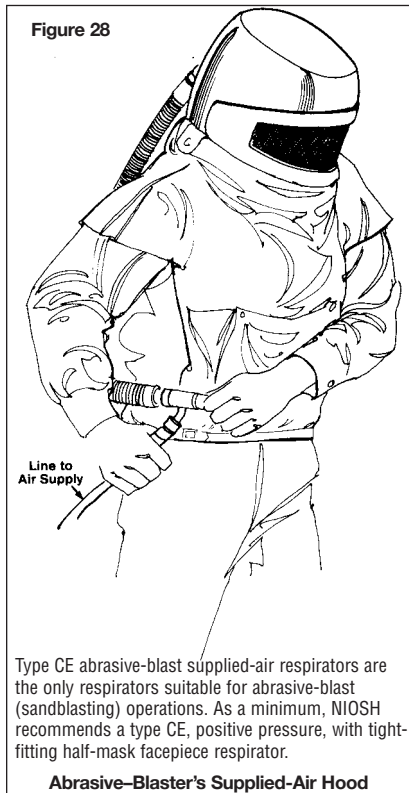


Figure 31



A powered air-purifying respirator (PAPR) blows a continuous supply of filtered air over the face. When working conditions are hot and humid, it provides more comfort than non-powered air-purifying respirators.

Remember: PAPRs are air-purifying and should never be used under oxygen-deficient conditions.

Battery Pack, Blower and Filter Housing

Powered Air-Purifying Respirators (PAPRs)

- b) Type of work to be done (e.g., painting, welding).
- c) Description of worksite conditions (e.g., inside a tank, outdoors).
- d) Exposure concentration, if known (e.g., 150 ppm of toluene).
- e) Whether the material will be heated, sprayed, etc.
- f) Other materials being used in the vicinity.

The respiratory protection specialist will evaluate this information and compare it with the following additional data:

- g) The permissible exposure limit of the dust, gas, or vapour, often referred to as the TLV® or Threshold Limit Value*. These values are used in conjunction with the protection factors listed in Table 1 to determine the maximum use concentration.

**TLV is a term copyrighted by the American Conference of Governmental Industrial Hygienists.*

- h) The physical properties of the contaminant:
 - Vapour Pressure — The maximum amount of vapour which can be generated under given conditions.
 - Warning Properties (e.g., irritation, odour, taste) — If the material has poor warning properties (for example, when the lowest concentration that can be detected by odour is

It is also important to realize that facial hair and deep facial scars can interfere with the seal between respirator and face. Respirators should only be selected by someone who understands all of these factors.

Before using or handling a controlled product, consult the material safety data sheet (MSDS). The MSDS will identify any respiratory protection required. Under the Workplace Hazardous Materials Information System (WHMIS), MSDSs must be available to users of control-led products. The MSDS should specify the type of respirator to be worn.

The chart at the end of this section is a guide to respirator selection. It is intended as a guide only and may not be applicable to every case.

For activities not listed, information regarding type of work, nature of material(s) involved, and working conditions is required and expert advice should be obtained.

If there is any doubt about the correct type of protection for a specific material and operation, consult the manufacturer of the product, a supplier or manufacturer of respirators, or CSAO. When seeking information on the type of respirator for use in specific situations, provide as much of the following information as possible:

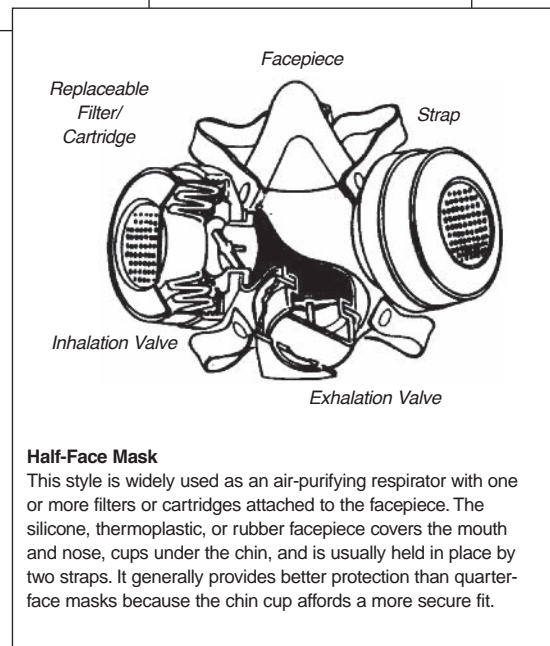
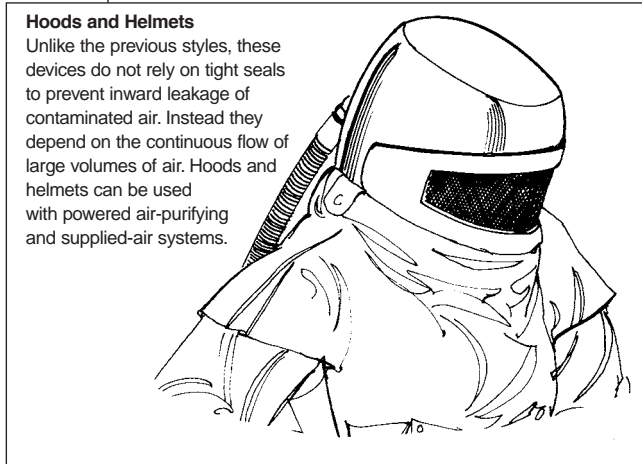
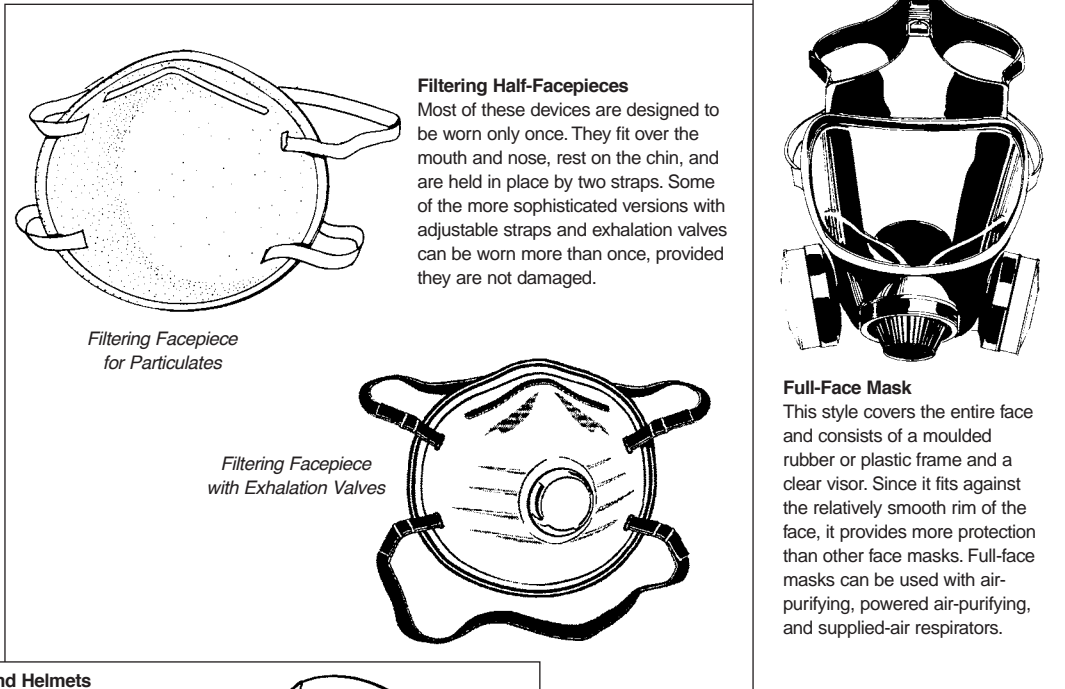
- a) Name and form of the material (oil or non-oil). If the form is unknown, consider it an oil.

greater than the permissible exposure concentration), air-purifying respirators are usually not permitted.

- Types of Effects — With cancer-causing materials a higher degree of protection is usually specified.
- Performance of Filters — With some gases and vapours the filter can become overloaded in just a few minutes. Therefore, knowledge of the filtering material and its performance against specific gases and vapours is necessary.

- i) The concentration considered to be Immediately Dangerous to Life or Health (IDLH). IDLH atmospheres pose an immediate threat to life or health or the threat of a serious but delayed effect on health (e.g., radioactive dust exposures). One example of an IDLH situation is the repair of a chlorine leak where a worker could be overcome by the gas very quickly. IDLH atmospheres should only be entered by persons wearing SCBA or SCBA/airline respirators as shown in Figures 29 and 30.
- j) Possibility of skin absorption. With some chemicals the amount of material which can be absorbed through the skin is of equal or greater concern than the amount of gas or vapour which can be inhaled. For these situations supplied-air protective suits may be necessary.

Figure 32



- k) Eye irritation — some contaminants will cause eye irritation, making it difficult to see. For these contaminants, a full-face mask must be worn.

As shown by points a) to k), many factors must be considered to ensure that the proper respirator is selected for a specific situation.

Note
Facial hair and eye protection can adversely affect the respirator seal. Facial hair between the face and a tight-fitting respirator can cause a great deal of leakage and reduce the effectiveness of protection significantly. Respirator wearers should be clean-shaven to achieve the best possible seal. Where eye protection with temple bars or straps passing between face and respirator is necessary, consider wearing a full-face mask.

Fit Testing and Seal Checks

Once a respirator has been selected, the next critical step is ensuring that it fits properly. One size does not fit all.

With every respirator except hoods or helmets, a tight seal is required between facepiece and face.

With negative-pressure respirators (e.g., non-powered air-purifying respirators and demand supplied-air respirators) gaps in the seal will permit contaminated air to enter the breathing zone.

With positive-pressure respirators (e.g., powered air-purifying respirators and pressure-demand supplied-air respirators) a lot of air will be wasted through outward

Table 7: Protection Factors (according to NIOSH)

Type of Respirator	Facepiece Style	Facepiece Pressure	Cartridge Type	Hazard Form	Protection Factor
Air-purifying	Filtering half-facepiece	N	N/A	Particle	10 ‡
	Half-face mask	N	1	Particle, gas, vapour	10 ‡
	Full-face mask	N	1	Particle	10
	Full-face mask	N	2	Particle	50
	Full-face mask	N	3	Gas, vapour	50 ‡
Powered air-purifying	Loose hood helmet	C	1	Particle, gas, vapour	25 ‡
	Tight-fitting facepiece	C	3	Gas, vapour	50 ‡
	Tight-fitting facepiece	C	2	Particle	50
Airline	Half-face mask	N	N/A	Particle, gas, vapour	10
	Half-face mask	P	N/A	Particle, gas, vapour	1,000
	Full-face mask	N	N/A	Particle, gas, vapour	50
	Full-face mask	P	N/A	Particle, gas, vapour	2,000
	Hood or helmet	C	N/A	Particle, gas, vapour	25
SCBA *	Half-face mask	P	N/A	Particle, gas, vapour	1,000
SCBA *	Full-face mask	N	N/A	Particle, gas, vapour	50
SCBA *	Full-face mask	P	N/A	Particle, gas, vapour	10,000

* SCBA or airline with emergency air bottle adequate for escape from the hazardous environment

‡ Protection factor may be limited by the cartridge. Check with manufacturer.

N Negative
 C Constant flow
 P Positive
 N/A Not applicable

1 Any appropriate NIOSH-approved
 2 High efficiency particulate aerosol (HEPA)
 3 Appropriate NIOSH-approved gas or vapour

leakage and the degree of protection provided to the wearer could be reduced. Also, “venturi effects” may allow air to escape in one area and draw contaminated air into the facepiece around the escaping air.

For these and other reasons, the fit of respirators must be carefully tested. Generally there are two types of fit testing — qualitative and quantitative.

Qualitative Fit Tests

- 1) **Irritant Smoke Test** — The wearer puts on the respirator with “high efficiency or fume filters” in place. A cloud of irritant smoke is created around the wearer. If leakage is detected the respirator should be adjusted.

Caution: Most of the smoke clouds used in this test are very irritating to the eyes, nose, and throat. Workers are advised to keep their eyes closed during the test and to back out of the smoke as soon as they notice any leakage or irritation.

- 2) **Iso Amyl Acetate (Banana Oil) Test** — The wearer puts on the respirator with “organic vapour” cartridge filters in place. A cotton swab dipped in iso amyl acetate solution is passed along the outline of the facepiece (iso amyl acetate smells like very ripe bananas). If the wearer smells the solution, the respirator should be adjusted.

Note: Some people cannot smell iso amyl acetate. Before starting the test, check to ensure that the person can detect the odour. Use two small jars, one containing water, the other containing the test solution. Ask the person whether one smells different and what it smells like.



- 3) **Saccharin Test** — This test is similar to the iso amyl acetate test except that it uses saccharin as the test material and a dust/mist or high efficiency respirator. If the sweet taste or smell of saccharin is detected, the fit must be adjusted.
- 4) **Bitrex Solution Aerosol Test** — In this test the wearer puts on the respirator with any particulate filter. A hood or test enclosure is put over the wearer’s head and shoulders. Bitrex is then sprayed into the hood or enclosure. Bitrex is a very bitter solution and can easily be detected if it leaks through the face seal. If the wearer cannot taste the Bitrex, then the respirator fits properly.

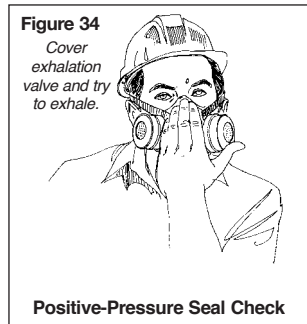
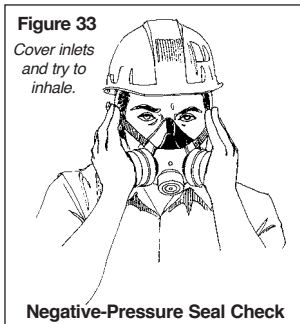
Quantitative Fit Tests

In these tests the wearer puts on a special respirator which has a probe mounted inside the facepiece. The wearer then goes into a test chamber or booth which contains a known concentration of a specific gas, vapour, or aerosol. The amount of leakage is determined by sampling the air inside the facepiece through the probe. This method is not well suited for use on most construction projects.

User Seal Checks

Every time you put a respirator on, check the seal using the negative-pressure and positive-pressure method.

- 1) **Negative Pressure Test** — The wearer puts on the respirator and adjusts it so that it feels relatively comfortable. Then the air inlets are blocked off with the hands or a plastic cover, and the wearer inhales gently (Figure 33). If the respirator is properly fitted, it should collapse slightly and not permit any air into the facepiece. If leakage is detected, the mask should be readjusted and the test repeated until the fit is satisfactory.
- 2) **Positive Pressure Test** — The wearer puts on the respirator and adjusts it so that it feels relatively comfortable. Then the exhaust port of the respirator is covered and the wearer tries to exhale gently (Figure 34). The facepiece should puff away from the wearer, but no leakage should occur.



Respirator Maintenance

Like any equipment, respirators require maintenance. The following instructions cover the major points.

- 1) Filters should be changed as follows:
 - Dust/mist/fume filters should be changed when there is noticeable resistance to normal breathing.
 - Chemical cartridge respirators should be changed when the gas or vapour can be tasted or smelled.
 - Any filter should be changed at the interval specified by the manufacturer or when damaged in any way.
- 2) Inhalation and exhalation valves should be checked before the respirator is used.
- 3) Damaged facepiece, straps, filters, valves, or other parts should be replaced with "original equipment" parts.
- 4) Facepieces should be washed with mild soapy water as often as necessary to keep them clean and wearable.
- 5) Respirators should be assigned to the exclusive use of individual workers.
- 6) Where a respirator must be assigned to more than one worker, it should be disinfected after each use (check with the manufacturer regarding acceptable

sanitizers/disinfectants).

- 7) Check all supply hoses, valves, and regulators on supplied-air respirators as specified by the manufacturer.
- 8) SCBA units and high-pressure cylinders of compressed breathing air should be used and maintained in accordance with current Canadian Standards Association Z180.1 *Compressed Breathing Air and Systems*, and Z94.4 *Selection, Care and Use of Respirators*.
- 9) Compressors and filtration systems used with supplied-air respirators must be maintained in accordance with the manufacturers' recommendations.
- 10) Consult manufacturer for information on respirator cartridge change-out.

Approvals and Standards

The most commonly referenced standards for respiratory protection in North America are the test criteria used by the National Institute for Occupational Safety and Health (NIOSH).

NIOSH is a U.S. government agency which tests and approves respiratory protective equipment as one of its major activities and publishes a list of approved devices annually.

The Construction Safety Association of Ontario recommends that only NIOSH-approved equipment be used for protection against respiratory hazards.

Unapproved devices should be evaluated carefully by a competent respiratory protection specialist before use.

The Canadian Standards Association has issued two standards pertaining to respiratory protection which should be reviewed by the person responsible for the respirator program:

- Z180.1 *Compressed Breathing Air and Systems* lists the criteria for air purity and delivery systems
- Z94.4 *Selection, Care and Use of Respirators* offers recommendations on these three aspects of the subject.

These standards are copyrighted by CSA. Copies can be purchased from

Canadian Standards Association
178 Rexdale Boulevard
Rexdale, Ontario
M9W 1R3
(416) 747-4000 www.csa.ca

Review

The following section lists common claims about respirators and explains why the statements are true or false. The information provides a convenient review of major points in this chapter.

- | | | |
|---|---------|---|
| 1) All respirators are the same. | (False) | Most respirators, especially air-purifying types, are limited to certain types of hazards. For instance, dust masks may be suitable for dusts, but do not provide protection against gases and vapours. |
| 2) One size fits all. | (False) | Most manufacturers offer three sizes of facepieces (small, medium and large) to ensure a proper fit. In some cases, no size from one manufacturer may fit an individual and a different brand may be necessary. |
| 3) Respirators make breathing more difficult. | (True) | With air-purifying respirators the air is being inhaled through a filter so some additional effort is required.

With most pressure/demand supplied-air respirators additional effort is required to activate the inhalation and exhalation valves. |
| 4) Air-purifying respirators supply oxygen. | (False) | These devices simply filter out specific gases, vapours, dust, mists, or fumes, but do not increase the oxygen content of the air. |
| 5) Most respirators require maintenance. | (True) | With the exception of disposable and single-use respirators, some maintenance is required. |
| 6) Any source of compressed air will be adequate for supplied-air respirators. | (False) | Compressed breathing air must be "clean" and free from carbon monoxide, oil mist, and other contaminants. |
| 7) Protection factors are the same for everyone. | (False) | The protection factors listed in Table 7 are averages obtained by testing a large number of wearers. Individual protection factors can be considerably different from those listed. |
| 8) Respirators are the best way to control respiratory hazards. | (False) | Good ventilation is the best way of controlling respiratory hazards, though it is not always practical in many construction applications. |
| 9) The moisture content of compressed air is important. | (True) | If the moisture content of the air in a pressurized breathing air system is too high, the regulators can freeze shut and cut off the supply of air. Moisture can also cause deterioration of storage cylinders. |
| 10) Parts can be interchanged from one manufacturer to another. | (False) | Using improperly fitted or matched components voids the NIOSH approval and can cause failure of the respirator posing serious risk to the wearer. |
| 11) Fitting of respirators is not important. | (False) | No matter how effective its protection against specific hazards, the respirator must be properly fitted to prevent inward leakage of contaminated air. The only exceptions are hoods and helmets, and even these depend on fit to a certain degree. |
| 12) Self-Contained Breathing Apparatus (SCBA) and air-line respirators provide the best protection. | (True) | They also have disadvantages which make their use impractical in some situations. |
| 13) Respirators should be checked each time they are used. | (True) | Damaged straps, missing or ill-fitting valves, and other problems can make the device useless. |
| 14) Only one respiratory hazard is present in a particular job. | (False) | Often there are two or more hazards present. For instance, spray painting produces mists and vapours while welding can produce fume and gases. |
| 15) Respirators can be fitted with filters suitable for more than one hazard. | (True) | Many manufacturers offer filters which will remove selected dusts, fumes, gases, and vapours all at the same time. |
| 16) Single-use dust masks should not be worn more than once. | (True) | These inexpensive respirators are meant to be put on once only. They may not provide adequate protection once the straps have been stretched. |


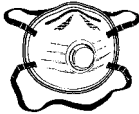
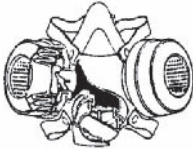

- | | | |
|--|---------|---|
| 17) Respirators provide absolute protection. | (False) | Every respirator has limitations which the wearer must understand. Protection is ensured not only by the respirator but also by its proper use. |
| 18) Respirators are simple to select for any job. | (False) | In many cases even the respiratory protection specialists have problems in selecting the right device. |
| 19) Respirators interfere with eye protection. | (True) | Protective goggles and glasses may not fit properly with many respirators. Full-face masks may be necessary. |
| 20) NIOSH approvals are important. | (True) | NIOSH approvals indicate that the device has passed a set of minimum design and performance standards. Unapproved respirators may provide similar protection but this can only be evaluated by expert review of the manufacturer's claims. |
| 21) Beards and mustaches do not affect respiratory protection. | (False) | With the exception of hoods and some helmets, beards and mustaches cause a great deal of leakage and reduce the effectiveness of respirators significantly. Respirator wearers should be clean shaven to obtain the best possible protection. |

Summary

Respiratory protective equipment can prevent illness, disease, and death from breathing hazards. But the equipment must be properly selected, fitted, worn, and maintained to ensure maximum protection.

The Construction Safety Association of Ontario can provide assistance in selecting respiratory protection and training workers in its use, care, and maintenance. For additional information, contact CSAO.

Respirator Selection Guide for Common Construction Activities

Air purifying											Supplied air		
Half facepiece						Full facepiece					Powered Air-Purifying Respirator (PAPR), tight-fitting	Hood or Helmet	SCBA or SCBA + airline, full facepiece and positive pressure
Filtering facepiece			Elastomeric facepiece										
													

Filter efficiency and type	95	100	95	100	Organic vapour	95+ organic vapour	100+ organic vapour	95	100	100+ organic vapour	HEPA		
Assigned Protection Factor* (NIOSH 1987)	10	10	10	10	10	10	10	10	50	50	50	1000	10,000

Asbestos: see Asbestos chapter in this manual.

Lead													
Application of lead-containing coatings with a brush or roller			Optional ✓ N, R, or P										
Spray application of lead-containing coatings											✓ Hood or helmet		
Removal of lead-containing coatings or materials by scraping or sanding using non-powered hand tools			✓ N, R, or P										
Removal of lead-containing coatings or materials using non-powered hand tools—other than manual scraping or sanding			Optional ✓ N, R, or P										
Removal of lead-containing coatings with a chemical gel or paste and fibrous laminated cloth wrap			Optional ✓ N, R, or P										
Removal of lead-containing coatings or materials using a power tool <i>without</i> a dust collection system equipped with a HEPA filter (airborne dust ≥ 0.05 mg/m ³)											✓ Full facepiece		

Continued on next page . . .


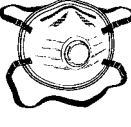


N = Not resistant to oil R = Oil-resistant P = Oil-proof OV = Organic vapour cartridge

✓ indicates suitable protection. If oil mist is present, use R or P filters.

* Assigned protection factor: The protection factor assigned by NIOSH, the US National Institute for Occupational Safety and Health. It's a measure of the effectiveness of a type of respirator and suitable filter. Higher numbers mean greater protection. You may use a respirator with a greater protection factor than the one recommended for your task. Never use a respirator with a smaller protection factor.

These recommendations will provide adequate protection in most circumstances. Factors such as ventilation, duration of exposure, and user characteristics can affect how well a respirator protects you. If unsure about the respirator required for a task, contact the manufacturer or CSAO at 1-800-781-2726, www.csa.org.

Respirator Selection Guide for Common Construction Activities

Air purifying											Supplied air		
Half facepiece						Full facepiece					Powered Air-Purifying Respirator (PAPR), tight-fitting	Hood or Helmet	SCBA or SCBA + airline, full facepiece and positive pressure
Filtering facepiece			Elastomeric facepiece										
													

Filter efficiency and type	95	100	95	100	Organic vapour	95+ organic vapour	100+ organic vapour	95	100	100+ organic vapour	HEPA		
Assigned Protection Factor* (NIOSH 1987)	10	10	10	10	10	10	10	10	50	50	50	1000	10,000


Lead cont'd

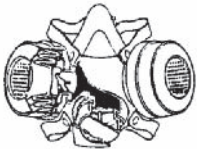
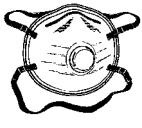
Removal of lead-containing coatings or materials using a power tool <i>with</i> a dust collection system equipped with a HEPA filter (airborne dust must be controlled to < 0.05 mg/m ³)			Optional ✓ N, R, or P										
Abrasive blasting of lead-containing coatings or materials												✓ Type CE blasting; positive pressure; tight-fitting half-facepiece	
Dry removal of lead-containing mortar using an electric or pneumatic cutting device											✓ Tight-fitting full facepiece		
Welding or high-temperature cutting of lead-containing coatings or materials indoors or in a confined space											✓ Tight-fitting full facepiece		
Welding or high-temperature cutting of lead-containing coatings or materials outdoors—long-term operations or if material not pre-stripped											✓ Tight-fitting full facepiece		
Welding or high-temperature cutting of previously stripped lead-containing coatings or materials outdoors—short term only			✓ N, R, or P										
Burning of a surface containing lead											✓ Tight-fitting full facepiece		
Soldering			Optional ✓ N, R, or P										
Installation or removal of lead-containing sheet metal			Optional ✓ N, R, or P										
Installation or removal of lead-containing packing, babbitt, or similar material			Optional ✓ N, R, or P										

Continued on next page . . .

N = Not resistant to oil R = Oil-resistant P = Oil-proof OV = Organic vapour cartridge

Respirator Selection Guide for Common Construction Activities

Air purifying											Supplied air		
Half facepiece						Full facepiece					Powered Air-Purifying Respirator (PAPR), tight-fitting	Hood or Helmet NIOSH type CE pressure demand Half-facepiece pressure demand	SCBA or SCBA + airline, full facepiece and positive pressure
Filtering facepiece			Elastomeric facepiece										




Filter efficiency and type	95	100	95	100	Organic vapour	95+ organic vapour	100+ organic vapour	95	100	100+ organic vapour	HEPA		
Assigned Protection Factor* (NIOSH 1987)	10	10	10	10	10	10	10	10	50	50	50	1000	10,000

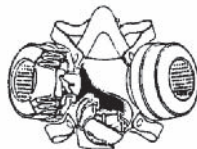
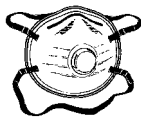
Lead cont'd														
Demolition or cleanup of a facility where lead-containing products were manufactured													✓ Tight-fitting full facepiece	
Manual demolition of lead-painted plaster walls or building components using a sledgehammer or similar tool		✓ N, R, or P												
Removal of lead-containing dust using an air-mist extraction system													✓ Pressure demand; full facepiece	
Removal or repair of a ventilation system used for controlling lead exposure													✓ Tight-fitting full facepiece	
An operation that may expose a worker to lead dust, fume, or mist, that is not a Type 1, Type 2, or Type 3b operation													✓ Tight-fitting full facepiece	

Painting														
Spraying latex paint	✓ N, R, or P (small-scale)		✓ N, R, or P (small-scale)					✓ N, R, or P (large-scale)						
Alkyds, enamels, and sealers: brush and roller application indoors but well-ventilated						✓ R or P								
Alkyds and enamels: spray painting in well-ventilated area								✓ R or P						
Alkyds and enamels: painting in a confined space														✓
Epoxy or polyurethane spray painting													✓	
Spraying lead paint										✓ N, R, or P	✓			
Spraying stucco							✓ R or P							

N = Not resistant to oil R = Oil-resistant P = Oil-proof OV = Organic vapour cartridge

Respirator Selection Guide for Common Construction Activities

Air purifying											Supplied air		
Half facepiece					Full facepiece						Powered Air-Purifying Respirator (PAPR), tight-fitting	Hood or Helmet	SCBA or SCBA + airline, full facepiece and positive pressure
Filtering facepiece		Elastomeric facepiece											



Filter efficiency and type	95	100	95	100	Organic vapour	95+ organic vapour	100+ organic vapour	95	100	100+ organic vapour	HEPA		
Assigned Protection Factor* (NIOSH 1987)	10	10	10	10	10	10	10	10	50	50	50	1000	10,000

Roofing

Removal of roofing material (built-up roofing, no asbestos)	✓ R or P		✓ R or P					✓ R or P					
Heat welding roofing membrane	✓ N, R, or P		✓ N, R, or P										
Adhesive welding roofing membrane					✓ N, R, or P								
Roofing kettle operators (asphalt)										✓ N, R, or P	✓ +OV		





Silica

Breaking concrete outdoors	✓ N, R, or P		✓ N, R, or P										
Crushing rock and gravel			✓ N, R, or P	✓ N, R, or P									
Blasting rock			✓ N, R, or P	✓ N, R, or P									
Abrasive blasting—either ≥ 1% silica in the abrasive blasting media or ≥ 1% silica in the target material being blasted											✓		
Drywall sanding		For short-term applications, a filtering facepiece respirator may be appropriate	✓ N, R, or P	✓ N, R, or P									
Machine mixing concrete or mortar			✓ N, R, or P	✓ N, R, or P									
Drilling holes in concrete or rock that is not part of a tunnelling operation or road construction			✓ N, R, or P	✓ N, R, or P									
Milling of asphalt from concrete highway pavement			✓ N, R, or P	✓ N, R, or P									
Charging mixers and hoppers with silica sand (sand consisting of at least 95% silica) or silica flour (finely ground sand consisting of at least 95% silica)			✓ N, R, or P	✓ N, R, or P									
Any other operation at a project that requires the handling of silica-containing material in a way that a worker may be exposed to airborne silica			✓ N, R, or P	✓ N, R, or P									

Continued on next page . . .

N = Not resistant to oil R = Oil-resistant P = Oil-proof OV = Organic vapour cartridge

Respirator Selection Guide for Common Construction Activities


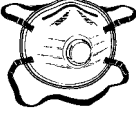


Air purifying										Supplied air		
Half facepiece					Full facepiece					Powered Air-Purifying Respirator (PAPR), tight-fitting	Hood or Helmet	SCBA or SCBA + airline, full facepiece and positive pressure
Filtering facepiece		Elastomeric facepiece										
												

Filter efficiency and type	95	100	95	100	Organic vapour	95+ organic vapour	100+ organic vapour	95	100	100+ organic vapour	HEPA		
Assigned Protection Factor* (NIOSH 1987)	10	10	10	10	10	10	10	10	50	50	50	1000	10,000

Silica cont'd													
Entry—for less than 15 minutes—into a dry mortar-removal or abrasive-blasting area for inspection or sampling where airborne dust is visible	For short-term applications, a filtering facepiece respirator may be appropriate	✓ N, R, or P	✓ N, R, or P										
Entry into an area where abrasive blasting is being carried out for more than 15 minutes	For short-term applications or applications involving tools or equipment with adequate controls (local exhaust ventilation or water), a half-facepiece respirator may be appropriate								✓ N, R, or P		✓		
Dry method dust clean-up from abrasive blasting operations									✓ N, R, or P		✓		
Removal of silica-containing refractory materials with a jackhammer									✓ N, R, or P		✓		
Drilling holes in concrete or rock as part of a tunnelling operation or road construction									✓ N, R, or P		✓		
Using a power tool to cut, grind, or polish concrete, masonry, terrazzo, or refractory materials									✓ N, R, or P		✓		
Using a power tool to remove silica-containing materials									✓ N, R, or P		✓		
Using a power tool indoors to chip or break and remove concrete, masonry, stone, terrazzo, or refractory materials									✓ N, R, or P		✓		
Tunnelling (operation of tunnel boring machine, tunnel drilling, tunnel mesh insulation)									✓ N, R, or P		✓		
Tuckpointing and surface grinding									✓ N, R, or P		✓		
Dry-mortar removal with an electric or pneumatic cutting device									✓ N, R, or P		✓		
Using compressed air outdoors to remove silica dust								✓ N, R, or P		✓			

N = Not resistant to oil R = Oil-resistant P = Oil-proof OV = Organic vapour cartridge

Respirator Selection Guide for Common Construction Activities

Air purifying											Supplied air		
Half facepiece						Full facepiece					Powered Air-Purifying Respirator (PAPR), tight-fitting	Hood or Helmet	SCBA or SCBA + airline, full facepiece and positive pressure
Filtering facepiece			Elastomeric facepiece										
													


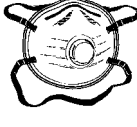


Filter efficiency and type	95	100	95	100	Organic vapour	95+ organic vapour	100+ organic vapour	95	100	100+ organic vapour	HEPA		
Assigned Protection Factor* (NIOSH 1987)	10	10	10	10	10	10	10	10	50	50	50	1000	10,000

Synthetic Vitreous Fibres (Man-made mineral fibres)													
Installation, removal, or blowing cellulose, fiberglass, mineral wool, or calcium silicate	✓ N, R, or P	✓ N, R, or P	✓ N, R, or P	✓ N, R, or P									
Installation of refractory ceramic fibres (silica may be present)				✓ N, R, or P									
Removal of refractory ceramic fibres (silica may be present)									✓ N, R, or P		✓		

Other dust and fibre exposure													
Removal of roofing material (built-up roofing, no asbestos)	✓ R or P		✓ R or P						✓ R or P				
Dry method dust clean-up from abrasive blasting operations	For short-term applications or applications involving tools or equipment with adequate controls (local exhaust ventilation or water) a half-facepiece respirator may be appropriate.									✓ N, R, or P		✓	
Wood dust, including pressure-treated wood dust	✓ N, R, or P		✓ N, R, or P										
Vinyl or laminate floor sanding	✓ N, R, or P		✓ N, R, or P										

N = Not resistant to oil R = Oil-resistant P = Oil-proof OV = Organic vapour cartridge

Respirator Selection Guide for Common Construction Activities

Air purifying											Supplied air		
Half facepiece						Full facepiece					Powered Air-Purifying Respirator (PAPR), tight-fitting 	Hood or Helmet NIOSH type CE pressure demand Half-facepiece pressure demand	SCBA or SCBA + airline, full facepiece and positive pressure
Filtering facepiece 			Elastomeric facepiece 										

Filter efficiency and type	95	100	95	100	Organic vapour	95+ organic vapour	100+ organic vapour	95	100	100+ organic vapour	HEPA		
Assigned Protection Factor* (NIOSH 1987)	10	10	10	10	10	10	10	10	50	50	50	1000	10,000

Welding and flame-cutting														
Any welding in confined spaces when the atmosphere is not monitored														✓
Aluminum**	✓ N, R, or P		✓ N, R, or P											
Mild steel	✓ N, R, or P		✓ N, R, or P											
Stainless steel	✓ N, R, or P		✓ N, R, or P											
Galvanized or plated metals	✓ N, R, or P		✓ N, R, or P											
Lead-painted steel: flame cutting or welding, short-term, not repeated, material stripped before work			✓ N, R, or P	✓ N, R, or P										
Welding or high-temperature cutting of lead-containing coatings or materials indoors or in a confined space									✓ N, R, or P		✓	✓		

Miscellaneous														
Epoxy adhesive (large-scale use)														✓
Solvents, adhesives, and epoxy (small scale)					✓ R or P									
Caulking compounds, solvent-based, large-scale use					✓ R or P									
Form oil spraying						✓ R or P								
Paving						✓ R or P								

** Protection from ozone may be required in some circumstances. Contact the respirator manufacturer.

N = Not resistant to oil R = Oil-resistant P = Oil-proof OV = Organic vapour cartridge

16 HAND/SKIN PROTECTION

In construction, exposed hands and skin are susceptible to physical, chemical, and radiation hazards. Personal hand/skin protection is often the only practical means of preventing injury from

- physical hazards—sharp or jagged edges on materials and tools; heat; vibration
- corrosive or toxic chemicals
- ultraviolet radiation.

Physical Hazards

For physical hazards such as sharp edges, splinters, and heat, leather gloves are the preferred protection. Cotton or other materials do not stand up well and are recommended only for light-duty jobs.

Vibration transferred from tools and equipment can affect hands and arms. One result may be hand/arm vibration syndrome (HAVS). This disease causes the following changes in fingers and hands:

- circulation problems such as whitening or bluish discoloration, especially after exposure to cold
- sensory problems such as numbness and tingling
- musculoskeletal problems such as difficulty with fine motor movements—for instance, picking up small objects.

Workers who use vibrating tools such as jackhammers, grinders, riveters, and compactors on a daily basis may develop HAVS. Preventing this disease requires cooperation between employers and workers.

Employers

- Provide power tools with built-in vibration-reducing components.
- Review exposure times and allow rest breaks away from vibrating tools.
- Ensure proper tool maintenance (worn grinding wheels or tool bearings can lead to higher vibration levels).
- Train exposed workers in prevention techniques.
- Provide anti-vibration gloves.

Workers

- Wear appropriate clothing in cooler weather to maintain core body temperature.
- Wear gloves whenever possible.
- Wear anti-vibration gloves when using power tools and equipment.
- Avoid smoking (smoking contributes to circulatory problems).
- Report any poorly functioning tools immediately.

Chemical Hazards

For protection against chemical hazards, the material safety data sheet (MSDS) for the product being used should identify whether gloves are needed and what they should be made of. MSDSs must be available on site for all controlled products being used.

Table 8: Glove Selection Chart

Chemical Name	Glove Selection
Acetone	Butyl Rubber
Cellosolve	PVA, PVC, Neoprene
Cellosolve Acetate	PVA, PVC
Cyclohexane	NBR, Viton®
Hexane	Neoprene, NBR, PVA
Methyl Alcohol	Neoprene, Rubber, NBR
Methyl Chloroform	PVA, Viton
Methylene Chloride	PVA, Viton
Methyl Ethyl Ketone	Butyl Rubber
Methyl Isobutyl Ketone	Butyl Rubber, PVA
Mineral Spirits	Neoprene
Naphtha	NBR, PVA
Perchloroethylene	NBR, PVA, Viton
Stoddard Solvent	PVA, NBR, Rubber
Toluene	PVA, Viton
Turpentine	PVA, NBR
Trichloroethylene	PVA, Viton
1, 1, 1 Trichloroethane	PVA, Viton
1, 1, 2 Trichloroethane	PVA, Viton
Xylene	PVA, Viton

PVA – Polyvinyl Alcohol
 PVC – Polyvinyl Chloride
 NBR – Nitrite Butyl Rubber
 Viton® – Dupont tradename product

Table 8 identifies glove materials to be worn for protection against chemicals that may injure the skin. This information can be used when the MSDS does not specify the type of glove to be worn.

CAUTION: Common glove materials have limited protective properties and do not protect against all hazards. Some solvents, degreasers, and other liquids can penetrate and/or dissolve rubber, neoprene, or PVC.

Ultraviolet Radiation

In recent years there has been growing concern over the health risks of exposure to the sun's ultraviolet (UV) radiation. Construction workers are particularly at risk because they often work outdoors.

Long-term health risks of UV exposure include skin cancer. Every year there has been an alarming increase in the incidence of skin cancer. Sunlight is the main source of UV radiation known to damage the skin and cause skin cancer. Exposure to the sun's UV radiation is widely recognized as a *highly preventable* cause of skin cancer.

Melanoma is the least common but most dangerous type of skin cancer. The incidence of melanoma in men is rising faster than all other cancers. According to the Canadian Dermatology Association (CDA), the mortality rate from malignant melanoma is increasing, particularly in middle-aged males.

Melanomas most often appear on the upper back, head, and neck. The CDA also notes that there is generally a lag time of 10 to 30 years for the clinical appearance of skin cancer to occur. Consequently, it is critical for young workers to beware of the cumulative effect of unprotected

sun exposure. The more time they spend unprotected in the sun, the higher the risk of developing skin cancer.

Although most construction workers generally cover up their arms, legs, and torso on site, their faces and necks are still exposed to the sun's harmful rays. In addition, areas like the tips of the ears and the lips are often overlooked when it comes to sun protection.

The type of skin cancer that develops on the ear or the lip has a high chance of spreading to other parts of the body and causing death. Melanoma may also occur on the sun-exposed parts of the head and neck.

In fact the majority of skin cancers (2 out of 3) occur on the head and neck, followed by the forearm and back of the hand. Workers too often leave these critical areas exposed to the harmful effects of UV radiation.

Individual risk factors for developing skin cancer include

- fair skin that burns easily
- blistering sunburns in childhood and adolescence
- family history of melanoma
- many freckles and moles.

In addition to the harmful effects of the sun's direct rays, some workers may be exposed to indirect UV radiation. Workers can receive additional radiation if they are on or near a surface that reflects sunlight. Reflective surfaces such as concrete, water, unpainted corrugated steel, building glass, and aluminum can increase the amount of ultraviolet radiation to which a worker is exposed.

Another source of indirect UV radiation is from the hard hat itself. UV rays can reflect off the hard hat onto a worker's face, magnifying the amount of UV exposure.

Although all construction workers are at risk, those who don't have ready access to shade and/or work at heights are at a higher risk for UV overexposure. These trades include

- concrete finishing workers
- roofers
- rodworkers
- formworkers on high-rise and residential sites
- roadworkers
- traffic signallers
- ironworkers.

In addition, working at sites with southern exposure decreases the daytime shade available and increases UV exposure.

Remember—even on cloudy or hazy days, UV radiation can penetrate the atmosphere and burn your skin.

What Workers Can Do

- ✓ Apply a broad-spectrum sunscreen with a sun protection factor (SPF) of 15 or greater to all exposed skin areas. Be sure to cover your ears and the back of your neck. Apply sunscreen 20 to 30 minutes before you go out in the sun. Reapply sunscreen every 2 hours.
- ✓ Use an SPF 15 or higher sunscreen lip balm and reapply every two hours. Skin cancers can develop on lips.

- ✓ You may add UV protection to the back of your neck by using fabric to block the sun's rays. Neck protectors that clip onto your hardhat are available.
- ✓ Wear UV-absorbent safety glasses (CSA-approved polycarbonate glasses incorporate this feature).
- ✓ Wear clothing that covers as much of the skin as possible. Tightly woven material will offer greater protection as a physical block to UV rays.
- ✓ If you sweat heavily, you may need to reapply sunscreen more often. Additionally, when clothing is wet, it loses some of its ability to block out the sun's rays. Ensure you have additional dry clothing if necessary.
- ✓ Try to find a shaded area for your breaks and lunch.
- ✓ Wear a wide-brim hard hat designed to protect your face and neck from the sun. Adding a glare guard under the peak of your hard hat will help reduce reflective UV rays.
- ✓ Examine your skin regularly for any unusual changes. The most important warning sign for skin cancer is a spot on the skin that is changing in size, shape, or colour. The danger signs include any wound or skin patch that doesn't heal properly or scales. Be particularly attentive to any mole that grows or becomes irregular in shape, especially if it is multi-coloured. If anything looks unusual, see your doctor as soon as possible. **Skin cancers detected early can almost always be cured.**

What Employers Can Do

- ✓ Supply workers with a broad-spectrum sunscreen with an SPF of 15 or higher.
- ✓ Ensure adequate shaded areas for workers on breaks and lunch.
- ✓ If possible, rotate workers to shaded areas of the jobsite.
- ✓ Educate workers on the hazards of UV radiation.
- ✓ Ensure that workers use UV-absorbent safety glasses.

The majority of skin cancers are preventable. Taking basic precautions can significantly reduce the health effects of chronic sun exposure.

17 HIGH-VISIBILITY CLOTHING

The construction regulation (O. Reg. 213/91) requires that any worker who may be endangered by vehicular traffic on a project must wear a garment that provides a high level of visibility.

There are two distinct features to high-visibility clothing.

Background Material

This is the fabric from which the garment is made. It must be fluorescent orange or bright orange in colour and afford increased daytime visibility to the wearer. Fluorescent orange provides a higher level of daytime visibility and is recommended.

Retroreflective Stripes or Bands

The stripes or bands must be fluorescent and retroreflective and be arranged on the garment with two vertical stripes down the front and forming an X on the back. The stripes must be yellow and 50 mm wide. Retroreflective stripes are to afford the worker both low-light and night-time visibility.



For night-time work, additional stripes or bands are required on the arms and legs. One way to meet this requirement is to dress workers in fluorescent orange coveralls with retroreflective bands or stripes attached.

Risk Assessment

Before selecting high-visibility garments, assess the risks to be controlled. Workers who require greater visibility, such as roadway construction workers, should wear clothing that is highly conspicuous under the conditions expected.

For further recommendations on high-visibility clothing, consult CSA's standard Z96-02.

18 GUARDRAILS

A worker at risk of falling certain distances (see below) must be protected by a guardrail system or, if guardrails are not practical, by a travel-restraint system, fall-restricting system, fall-arrest system, or safety net. In many cases, guardrails are the most reliable and convenient means of fall protection and they must be your first consideration.

Guardrails or, if guardrails are impractical, other appropriate methods of fall protection must be used when

- a worker could fall more than 3 metres (10 feet) from any location
- there is a fall hazard of more than 1.2 metres, if the work area is used as a path for a wheelbarrow or similar equipment
- a worker could have access to the unprotected edge of any of the following work surfaces and is exposed to a fall of 2.4 metres (8 feet) or more:
 - a floor, including the floor of a mezzanine or balcony
 - the surface of a bridge
 - a roof while formwork is in place
 - a scaffold platform or other work platform, runway, or ramp.
- there are openings in floors, roofs, and other working surfaces not otherwise covered or protected
- there are open edges of slab formwork for floors and roofs
- a worker may fall into water, operating machinery, or hazardous substances.

Basic requirements for wood guardrails (Figure 33) include

- top rail, mid rail, and toeboard secured to vertical supports
- top rail between 0.9 m (3 feet) and 1.1 m (3 feet 7 inches) high

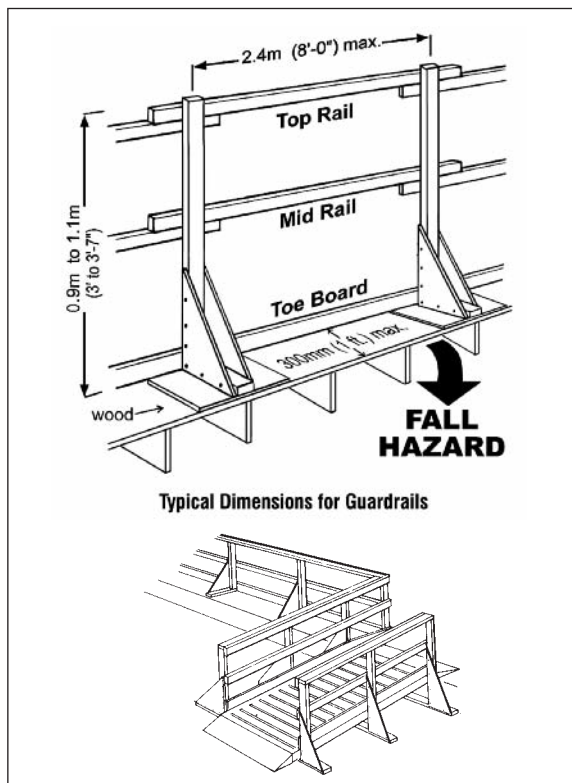
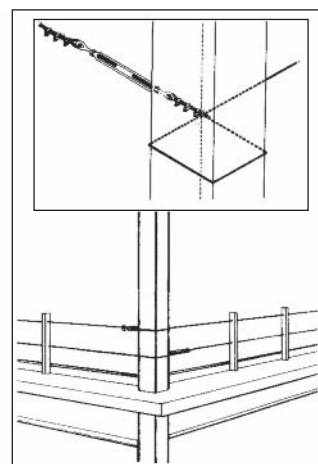
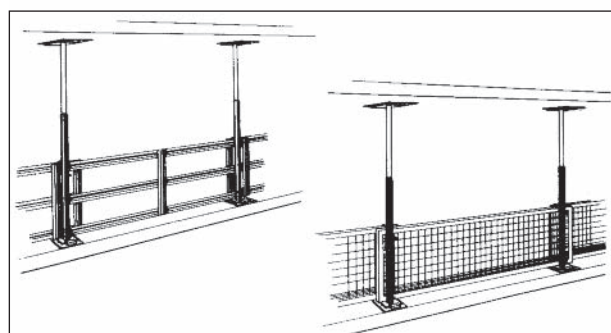


Figure 33



Wire Rope Guardrail System



Manufactured Safety Fences

Figure 34

- toeboard at least 100 mm (4 inches) high – 89 mm (3 1/2 inches) high if made of wood – and installed flush with the surface
- posts no more than 2.4 metres (8 feet) apart.

Other systems are acceptable (Figure 34) if they are as strong and durable as wood guardrails with the same minimum dimensions.

Guardrails must be installed no farther than 300 mm from an edge.

A guardrail must be capable of resisting – anywhere along its length and without exceeding the allowable unit stress for each material used – the following loads when applied separately:

- a point load of 675 newtons (150 lb) applied laterally to the top rail
- a point load of 450 newtons (100 lb) applied in a vertical downward direction to the top rail
- a point load of 450 newtons (100 lb) applied in a lateral or vertical downward direction to the mid-rail
- a point load of 225 newtons (50 lb) applied laterally to the toeboard.

Support

Typical methods of supporting wood guardrails are shown in Figure 33. Posts extending to top rail height must be braced and solidly fastened to the floor or slab.

Shoring jacks used as posts should be fitted with plywood softener plates top and bottom. Snug up and check the posts regularly for tightness.

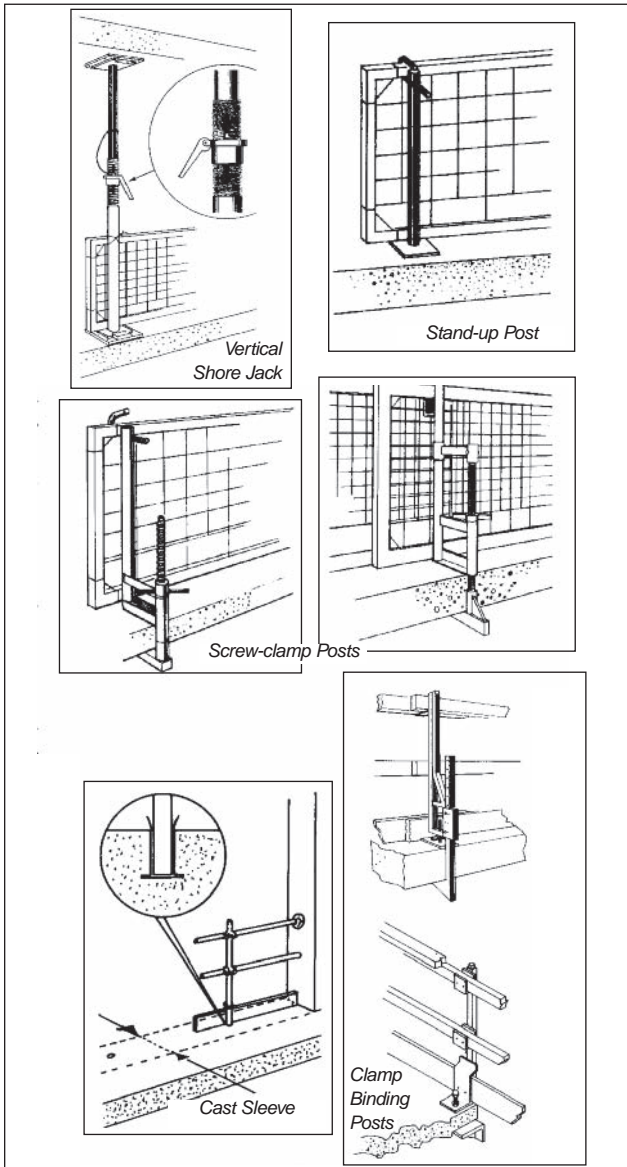


Figure 35

For slabs and the end of flying slab forms, manufactured posts can be attached to the concrete with either clamps or inset anchors (Figure 35).

Maximum Strength

To strengthen guardrails, reduce the spacing of posts to between 1 and 2 metres (3 feet and 4 inches and 6 feet and 8 inches) and double the 2 x 4 top rail. Posts on wooden guardrails must not be further apart than 2.4 metres (8 feet).

Where guardrails must be removed, open edges should be roped off and marked with warning signs. Workers in the area must use a fall-arrest or travel-restraint system (Figure 36).

Floor Openings

Guardrails are the preferred method for protecting workers near floor openings but may not always be practical. Narrow access routes, for example, may rule them out. In such cases, securely fastened covers – planks, plywood, or steel plates – may be the best alternative.

Use 48 mm x 248 mm (1 7/8" x 9 3/4") full-sized No. 1 spruce planks.

Make opening covers stand out with bright paint. Include a warning sign – DANGER! OPENING – DO NOT REMOVE! DO NOT LOAD!

Fasten the cover securely to the floor to prevent workers from removing it and falling through the opening.

Stairs

The open edges of stairs require guardrail protection. Specifications for a wooden arrangement are shown in Figure 37.

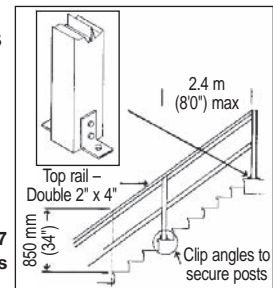
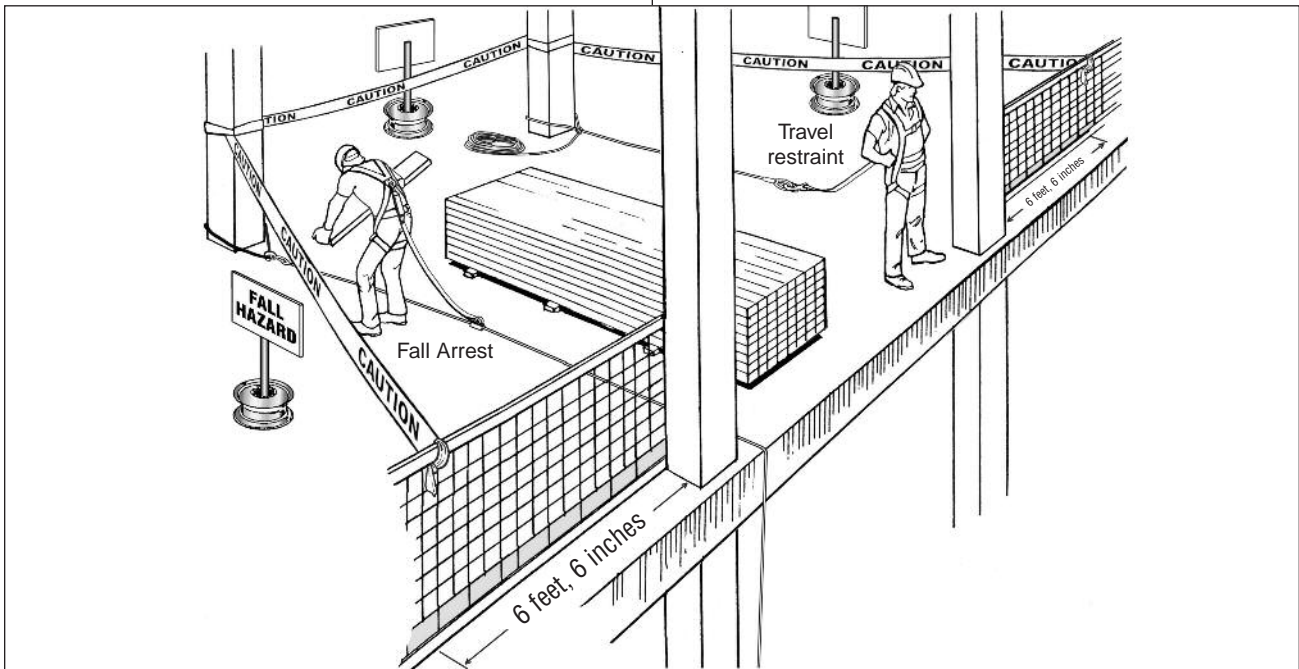


Figure 37
Guardrails on Stairs

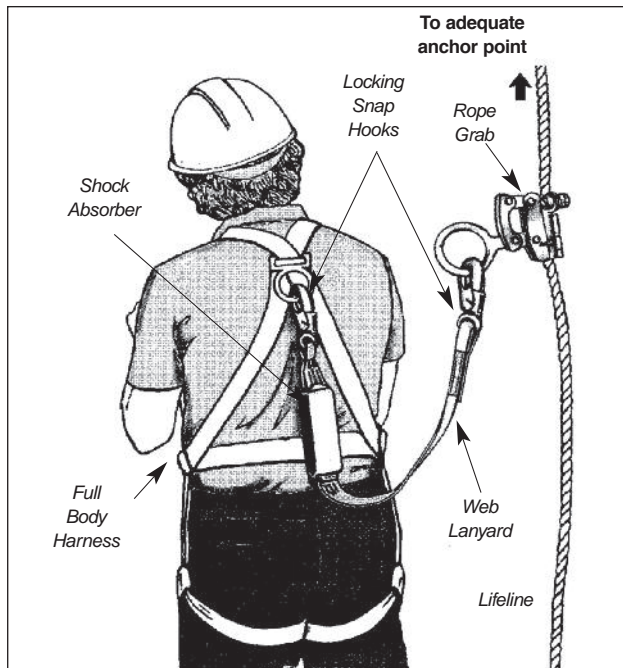


19 PERSONAL FALL PROTECTION

A worker at risk of falling certain distances (see chapter on Guardrails in this manual) must be protected by guardrails or, if guardrails are not practical, by a travel-restraint system, fall-restricting system, fall-arrest system, or safety net. This chapter describes travel-restraint systems and fall-arrest systems.

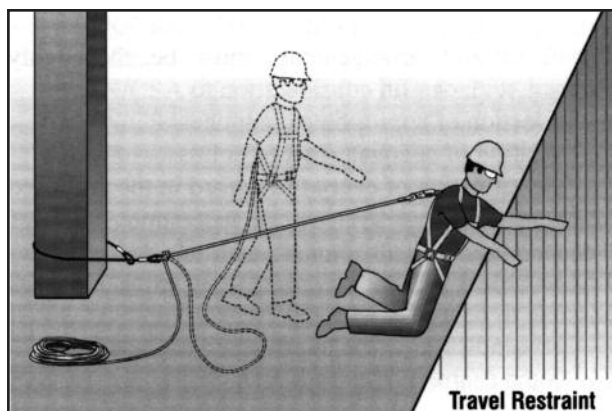
Personal fall protection equipment consists of the components shown in the following illustration.

This equipment can be used for travel restraint or fall arrest.



Travel-Restraint Systems

A travel-restraint system lets a worker travel just far enough to reach the edge but not far enough to fall over.



The basic travel-restraint system consists of

- CSA-approved full body harness
- lanyard
- lifeline
- rope grab to attach harness or lanyard to lifeline
- adequate anchorage (capable of supporting a static load of 2 kilonewtons—450 pounds—with a

recommended safety factor of at least 2, that is, 4 kilonewtons or 900 pounds).

Travel-restraint arrangements must be thoroughly planned, with careful consideration given to

- selection of appropriate components
- location of adequate anchor points
- identification of every fall hazard in the proposed work area.

Try to select an anchor point that is as close as possible to being

- perpendicular to the unprotected edge, and
- at the centre of the work area.

All fall hazards in the work area must be identified. Pay special attention to work areas with irregular shaped perimeters, floor openings, or locations near corners.

A fully extended lifeline and/or lanyard that adequately restrains a worker from a fall hazard in one section of the work area may be too long to provide the same protection in another section.

Two methods of travel restraint are commonly used in construction.

- 1) Connecting an adequately anchored lifeline directly to the D-ring of the worker's full body harness. It's absolutely critical that the length of the lifeline, measured from the anchor point, is short enough to restrain the worker from any fall hazard.
- 2) Attaching a lanyard from the D-ring of the worker's full body harness to a rope grab on an adequately anchored lifeline. There must be some means—such as a knot in the lifeline—to prevent the rope grab from sliding along the lifeline to a point where the worker is no longer restrained from falling.

Whether method 1 or 2 is used, the system must be adjusted so that the fully extended lifeline and/or lanyard prevents the worker from reaching any point where the worker may fall. The system must also be securely anchored.

Fall-Arrest Systems

Where workers cannot be protected from falls by guardrails or travel restraint, they must be protected by at least one of the following methods:

- fall-restricting system
- safety net
- fall-arrest system.

In the event of a fall, these systems must keep a worker from hitting the ground, the next level below, or any other objects below.

A fall-restricting system is designed to limit a worker's free fall distance to 0.6 metres (2 feet). One type uses a belt grab or belly hook that attaches to a safety rail on a fixed ladder.

A safety net system must be designed by a professional engineer. The system is installed below a work surface where a fall hazard exists.

A fall-arrest system

- must include a CSA-approved full body harness

- must include a lanyard equipped with a shock absorber unless the shock absorber could cause a falling worker to hit the ground or an object or a level below the work
- must include an adequate fixed support; the harness must be connected to it via a lifeline, or via a lanyard and a lifeline
- must prevent a falling worker from hitting the ground or any object or level below the work
- must not subject a falling worker to a peak fall-arrest force greater than 8 kilonewtons.

The construction regulation (O. Reg. 213/91) requires that

- all fall protection equipment must be inspected for damage, wear, and obvious defects by a competent worker before each use
- any worker required to use fall protection must be trained in its safe use and proper maintenance.

Any defective component should be replaced by one that meets or exceeds the manufacturer's minimum performance standards for that particular system.

The regulation also requires that any fall-arrest system involved in a fall be removed from service until the manufacturer certifies all components safe for reuse.

For any worker receiving instruction in fall protection, the manufacturer's instructions for each piece of equipment should be carefully reviewed, with particular attention to warnings and limitations.

Components

Canadian fall protection standards are regularly updated to incorporate the most current changes to fall protection systems. The following is a list of current CSA standards for personal fall protection equipment:

- CAN/CSA-Z259.1-M99 – *Body Belts and Saddles for Work Positioning and Travel Restraint*
- CAN/CSA-Z259.10-06 – *Full Body Harnesses*
- CAN/CSA-Z259.11 – *Energy Absorbers and Lanyards*
- CAN/CSA-Z259.12 – *Connecting Components for Personal Fall Arrest Systems (PFAS)*
- CAN/CSA-Z259.14 – *Fall Restrict Equipment for Wood Pole Climbing*
- CAN/CSA-Z259.2.1 – *Fall Arresters, Vertical Lifelines and Rails*
- CAN/CSA-Z259.2.2 – *Self-Retracting Devices for Personal Fall-Arrest Systems*
- CAN/CSA-Z259.2.3 – *Descent Control Devices*

For any component not covered by these standards, confirm with the manufacturer that the component is suitable for the particular system being considered.

The minimum strength of fall-arrest components depends on whether or not the system uses a shock absorber.

- In systems *without* shock absorbers, all components, including lifeline and lifeline anchorage, must be able to support a static load of at least 8 kilonewtons (1800 pounds) without exceeding the allowable unit stress of the materials used for each component.
- In systems *with* shock absorbers, all components, including lifeline and lifeline anchorage, must be able to support a static load of 6 kilonewtons (1350 pounds) without exceeding the allowable unit stress of the materials used for each component.

In designing both systems, it is recommended that a safety factor of at least two be applied to the stated minimum load capacity. In practical terms, anchorage should be strong enough to support the weight of a small car (about 3600 pounds).

Lifelines

There are three basic types of lifelines:

- 1) vertical
- 2) horizontal
- 3) retractable.

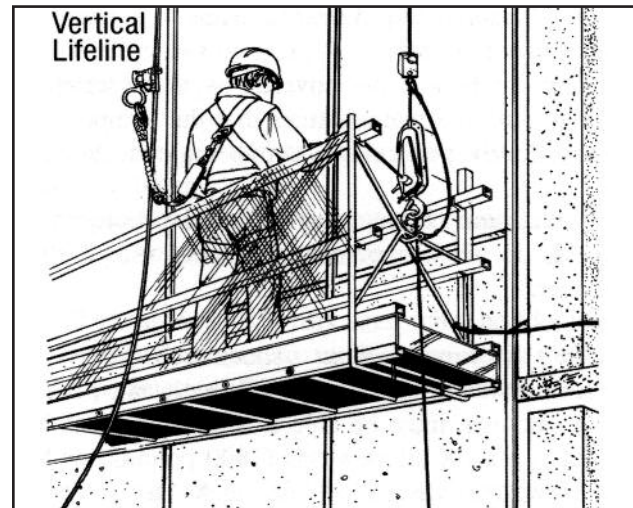
All lifelines must be inspected daily to ensure that they are

- free of cuts, burns, frayed strands, abrasions, and other defects or signs of damage
- free of discolouration and brittleness indicating heat or chemical exposure.

1) Vertical Lifelines

Vertical lifelines must comply with the current edition of the applicable CSA standard and the following minimum requirements:

- Only one person at a time may use a vertical lifeline.
- A vertical lifeline must reach the ground or a level above ground where the worker can safely exit.
- A vertical lifeline must have a positive stop to prevent the rope grab from running off the end of the lifeline.



Vertical lifelines are typically 16-millimetre (5/8-inch) synthetic rope (polypropylene blends).

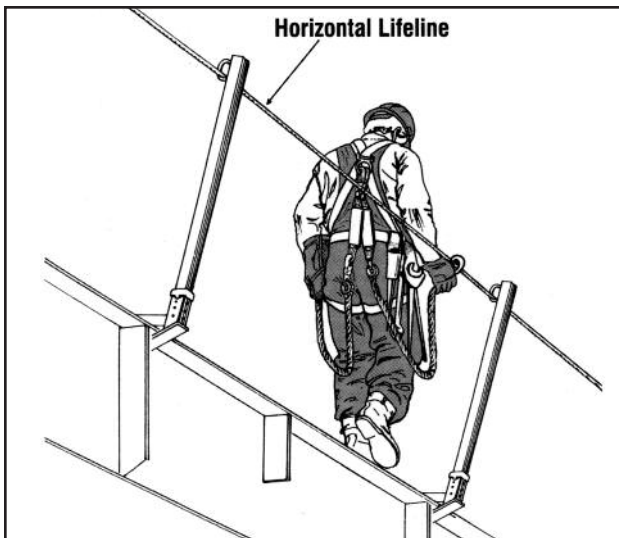
2) Horizontal Lifelines

The following requirements apply to any horizontal lifeline system:

- The system must be designed by a professional engineer according to good engineering practice.
- The design can be a standard design or specifically engineered for the site.

The design for a horizontal lifeline system must

- ✓ clearly indicate how the system is to be arranged, including how and where it is to be anchored
- ✓ list and specify all required components
- ✓ clearly state the number of workers that can safely be attached to the lifeline at one time



- ✓ spell out instructions for installation, inspection, and maintenance
- ✓ specify all of the design loads used to design the system.

The system must be installed, inspected, and maintained in accordance with the professional engineer's design.

Before each use, the system must be inspected by a professional engineer or competent worker designated by a supervisor. A complete and current copy of the design must be kept on site as long as the system is in use.

CAUTION: The construction regulation requires that "a horizontal or vertical lifeline shall be kept free from splices or knots, except knots used to connect it to a fixed support." Knots along the length of either a horizontal or vertical lifeline can reduce its strength by as much as 40%.

3) Retractable Lifelines

Retractable lifelines consist of a lifeline spooled on a retracting device attached to adequate anchorage. Retractable lifelines must comply with CAN/CSA-Z259.2.2.

In general, retractable lifelines

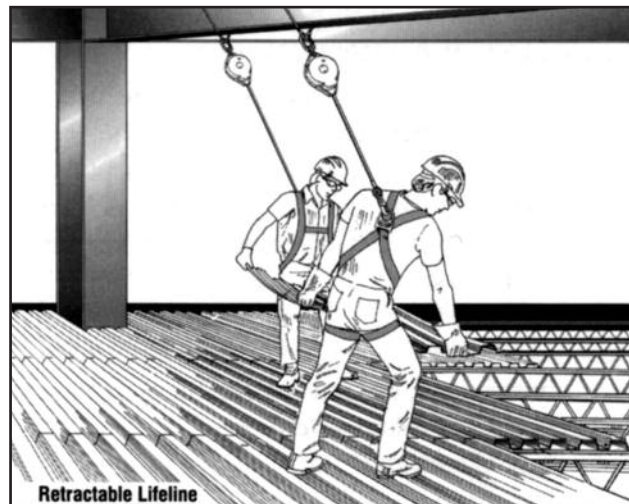
- are usually designed to be anchored above the worker
- employ a locking mechanism that lets line unwind off the drum under the slight tension caused by a user's normal movements
- automatically retract when tension is removed, thereby preventing slack in the line
- lock up when a quick movement, such as that caused by a fall, is applied
- are designed to minimize fall distance and the forces exerted on a worker's body by fall arrest.

Always refer to the manufacturer's instructions regarding use, including whether a shock absorber is recommended with the system.

Any retractable lifeline involved in a fall arrest must be removed from service until the manufacturer or a qualified testing company has certified it for reuse.

Lifeline Hazards

Ultraviolet light – Exposure to the sun may damage or weaken synthetic lifelines. Ensure that material being considered for lifelines is UV-resistant.



Temperature – Extreme heat can weaken or damage some lifelines while extreme cold can make others brittle. Ensure that material being considered for lifelines can stand up to the most extreme conditions expected.

Friction and abrasion – Normal movement may wear, abrade, or otherwise damage lifelines in contact with sharp or rough surfaces. Protection such as wood softeners or rubber mats can be used at contact points to prevent wear and tear.

Sparks or flame – Hot work such as welding or flame cutting can burn, melt, cut, or otherwise damage a lifeline. Ensure that material being considered for lifelines is flame-resistant or provide appropriate protection where sparks or flame may be encountered.

Chemicals – Chemical exposure can burn or degrade a lifeline very quickly. Ensure that material being considered for lifelines will resist any chemicals encountered on the job.

Storage – Always store lifelines separately. Never store them where they may contact hazards such as sharp objects, chemicals, or gasoline.

Anchor Systems

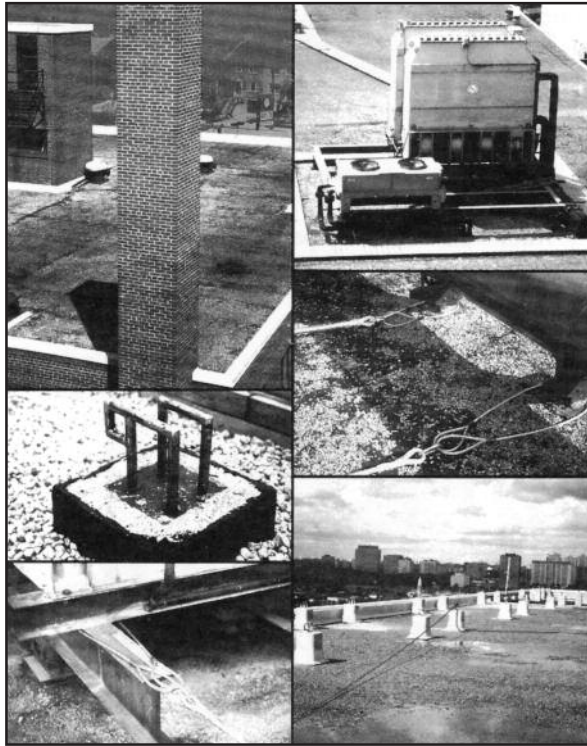
There are three basic types of anchor systems for fall protection:

- 1) **designed fixed support** – load-rated anchors specifically designed and permanently installed for fall protection purposes as an integral part of the building or structure (for example, roof anchors on high-rise buildings)
- 2) **temporary fixed support** – anchor systems designed to be connected to the structure using specific installation instructions (for example, nail-on anchors used by shinglers)
- 3) **existing structural features or equipment not intended as anchor points but verified by a professional engineer or competent person as having adequate capacity to serve as anchor points** (for example, rooftop mechanical rooms, structural steel, or reinforced concrete columns).

Designed fixed support can be used to anchor a fall-arrest system, fall-restricting system, or travel-restraint system if the support has been installed according to the *Building Code* and is safe and practical to use.

Temporary fixed support can be used as anchorage if it meets the following conditions:

- ✓ it can support at least 8 kilonewtons (1800 pounds) without exceeding the allowable unit stress for each material used;
- ✓ when used with a fall-arrest system incorporating a shock absorber, it can support at least 6 kilonewtons (1350 pounds) without exceeding the allowable unit stress for each material used; or



Examples of adequate anchorage

- ✓ when used with a travel-restraint system, it can support at least 2 kilonewtons (450 pounds) without exceeding the allowable unit stress for each material used.

In all cases, a **safety factor of at least two** should be applied when determining the minimum load that an anchor point must support.

As a general rule with fall-arrest systems, choose an anchor capable of supporting the weight of a small car (about 3600 pounds).

When existing structural features or equipment are used as anchor points, avoid corners or edges that could cut, chafe, or abrade fall protection components.

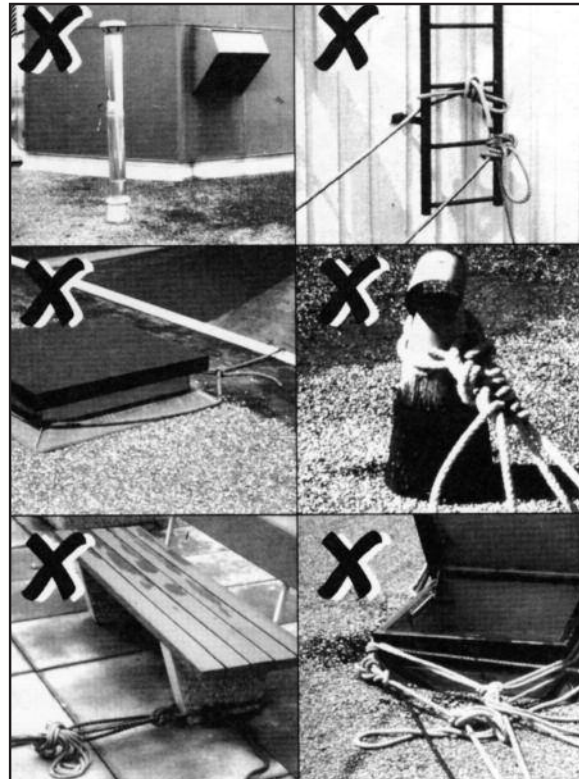
Where necessary, use softeners such as wood blocking to protect connecting devices, lifelines, or lanyards from damage.

Never anchor to

- roof vents or stink pipes
- roof hatches
- small pipes and ducts
- metal chimneys
- TV antennas
- stair or balcony railings.

Full Body Harness

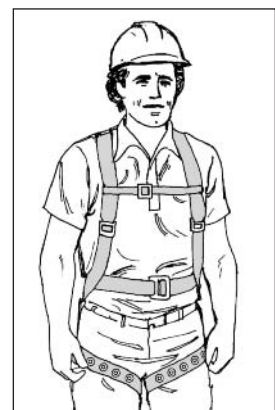
- Chest strap should be adjusted so that it's snug and located near the middle of the chest. In a headfirst fall a properly adjusted chest strap will prevent the worker from coming out of the harness.
- Leg straps should be adjusted so the user's fist can fit snugly between strap and leg.
- Harness straps should be adjusted to put the D-ring between the shoulder blades. A properly positioned D-ring will keep a worker upright after fall arrest.



Examples of inadequate anchorage

Inspect harness for

- ✓ burns, cuts, or signs of chemical damage
- ✓ loose or broken stitching
- ✓ frayed web material
- ✓ D-ring and keeper pads free from distortion and signs of undue wear or damage
- ✓ grommets and buckles free of damage, distortion, or sharp edges.



Lanyards

- Use manufactured lanyards only. They can be made of wire rope, synthetic fibre rope, or synthetic webbing.
- Lanyards are manufactured to specific lengths. Never try to shorten a lanyard by tying knots in it. Knots can seriously reduce its rated strength.
- Never store lanyards around chemicals, sharp objects, or in wet places. Never leave them exposed for long periods to direct sunlight.
- Inspect lanyards for

- ✓ burns, cuts, or signs of chemical damage
- ✓ loose or broken stitching
- ✓ frayed web material.

Shock Absorbers

- Shock absorbers absorb some of the force generated by fall arrest. Shock absorbers can be purchased as separate equipment or built into lanyards.
- One end of the shock absorber must be connected to the D-ring on the full body harness.
- In most cases the shock-absorbing component is enclosed in a snug-fitting jacket to protect it from the user's day-to-day activities. In a fall, the jacket tears open as the shock absorber deploys.
- Check the cover jacket for stress or tearing (many shock absorbers have a tag on the jacket that tears if the unit is exposed to a shock load—make sure this tag is intact).
- Ensure that a shock absorber built into a lanyard has a constant cross-section or diameter.

Connecting Devices

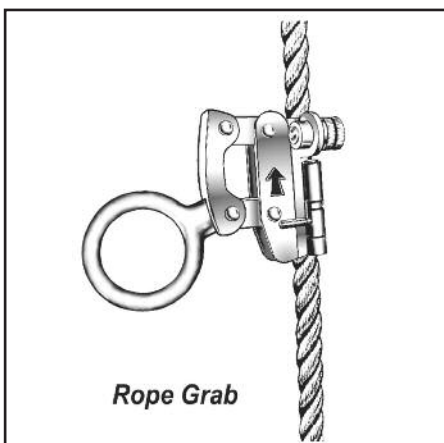
Locking Snap Hook – has a spring-loaded keeper across the opening of the hook that cannot be opened unless the locking mechanism is depressed.

Karabiner (D-Clip) – designed not to open under twist loads. To open the gate or keeper requires two separate actions: 1) twisting the locking mechanism and (2) pulling the locking mechanism back. When released, the spring-loaded locking mechanism flicks back into the locked position.

Rope Grab – used to connect lanyard to lifeline. These devices can be moved up and down the lifeline when a steady force is applied but will lock when a sharp tug or pull is applied. They will remain locked on the lifeline until the applied force is released.

Each rope grab is designed and manufactured for use with a specific diameter and type of lifeline. **Rope grab and lifeline must be compatible.** Specifications are usually listed on the housing.

The rope grab must also be attached to the lifeline in the correct direction—not upside down. On most rope grabs an arrow indicates the direction in which to orient the device. In addition, each rope grab is designed for use with a specific length of lanyard, normally two or three feet maximum.



Rope Grab

Check all connecting devices for

- ✓ damage, cracking, dents, bends, or signs of deformation
- ✓ connecting rings centred—not bent to one side or otherwise deformed
- ✓ rust
- ✓ moving parts working smoothly
- ✓ signs of wear or metal fatigue.

Fall-Arrest Planning

Before deciding on a fall-arrest system, assess the hazards a worker may be exposed to in case of a fall.

Before the fall is arrested, will the worker "bottom out," that is, hit ground, material, equipment, or a lower level of the structure? Will the pendulum effect cause the worker to swing from side to side, possibly striking equipment, material, or structure? In the event of fall arrest, how will the suspended worker be rescued? Planning must take into account these and other concerns.

Total Fall Distance is the distance required to fully arrest a fall. It consists of

- Free Fall Distance, which should be kept to 1.5 metres (5 feet) or less, plus
- Fall Stopping Distance, which includes stretch in the lanyard (minimal) and lifeline, slack in the harness (maximum 30 cm or 1 foot due to allowable adjustments for user's comfort), and deployment of the shock absorber (maximum 1.1 metres—or 42 inches).

Free Fall Distance is measured from the D-ring of a worker standing on the work surface down to the point where either the lanyard or the shock absorber begins to arrest the fall. It is strongly recommended that this distance be kept as short as possible.

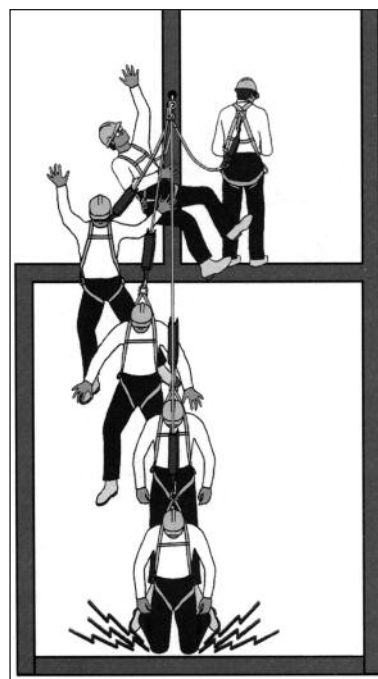
To minimize free fall, workers should tie off to an anchor overhead and use as short a lanyard as the work will allow.

Where a worker is connected to a vertical lifeline by a rope grab, the rope grab should be positioned as high above the D-ring as the work will allow. By doing this, the worker minimizes not only the Free Fall Distance but also the Fall Stopping Distance required to completely arrest a fall.

Bottoming Out

Bottoming out occurs when a falling worker hits a lower level, the ground, or some other hazard before the fall is fully arrested.

This occurs when Total Fall Distance is greater than the distance from the work



Bottoming Out

surface to the next level, the ground, or some other hazard below.

Fall-arrest systems must be planned, designed, and installed to prevent any risk of bottoming out.

Pendulum Effect

The farther you move sideways from your anchor point, the greater the chance of swinging if you fall. This is known as the "pendulum effect." And the more you swing, the greater the force with which you'll strike columns, walls, frames, or other objects in your path.

Swinging may even cause your taut lanyard or lifeline to break where it runs over rough or sharp edges.

Swing Fall or Pendulum Effect



To minimize pendulum effect, workers should keep lanyard or lifeline perpendicular from edge to anchor. Where work extends along an open edge, anchor points can be changed to keep lanyard or lifeline perpendicular as work progresses.

Another solution is to run a horizontal lifeline parallel to the edge. The worker attaches lanyard to lifeline, moves along the edge, and the lanyard travels at the same pace, remaining close to perpendicular at all times.

Emergency Rescue

The construction regulation (O. Reg. 213/91) requires that before workers use any fall-arrest system or safety net on a project, the employer must develop written rescue procedures. It's important that a worker involved in a fall arrest be brought to a safe area as quickly as possible without causing injury or putting rescuers at risk.

In many cases, the rescue plan can be simple. A ladder or elevating work platform can be used to reach suspended workers and get them down safely. Other workers may be hauled back up to the level from which they fell or pulled in through a nearby window or other opening.

In other cases, procedures may be more complicated. For instance, workers trapped on a failed swingstage, or hanging from it, may need to be rescued by specially trained and equipped personnel from the local fire

department. Aerial ladder trucks or other high-reach equipment may be necessary. In extreme cases, the fire department may use rappelling techniques to reach trapped workers and lift or lower them to a safe level.

Plans should cover the on-site equipment, personnel, and procedures for different types of rescue. Any off-site rescue services that might be required should be contacted and arranged in advance to familiarize them with the project. CSAO's Emergency Response poster (P103) can be used to indicate the nearest hospital and the phone numbers of fire, ambulance, and police services.

Site management must ensure that

- everyone on site is aware of the rescue plan
- equipment and other resources are available
- designated personnel are properly trained.

Workers must receive training from their employer regarding the specific fall protection equipment and procedures they will use. Products differ not only between manufacturers but also between product lines in a single company. Training must therefore cover the exact harness, lanyard, shock absorber, rope grab, lifeline, and anchorage each worker will rely on, as well as the applications to be encountered.

Conclusion

Employers, supervisors, and workers all have responsibilities in reducing or eliminating falls in construction.

This section has provided guidelines for fall protection, including both fall prevention and fall arrest. But the information means nothing unless employers, supervisors, and workers apply it on the job.

Workers who have any questions about fall hazards or fall protection should ask their supervisor. When it comes to fall protection, make sure you know how the equipment works and how to use it. Your life depends on it.

20 LADDERS

INTRODUCTION

Every year in the Ontario construction industry more than 800 lost-time injuries are caused by ladder accidents. Many of these accidents involve falls resulting in serious injuries and fatalities. Falls from ladders are common to all trades and pose one of the most serious safety problems in construction. The following are major causes of accidents.

- Ladders are not held, tied off, or otherwise secured.
- Slippery surfaces and unfavourable weather conditions cause workers to lose footing on rungs or steps.
- Workers fail to grip ladders adequately when climbing up or down.
- Workers take unsafe positions on ladders (such as leaning out too far).
- Placement on poor footing or at improper angles causes ladders to slide.
- Ladders are defective.
- High winds cause ladders to topple.
- Near electrical lines, ladders are carelessly handled or improperly positioned.
- Ladder stabilizers are not used where appropriate.

To assist supervisors and foremen in preventing such accidents, this chapter provides guidelines for selecting, setting up, maintaining, and using ladders. Because ladders are the most common type of access equipment in the construction industry, thousands are used every working day. As a result, there are many thousands of hours of exposure to ladder hazards every week.

The extensive exposure, the high fatality rate, and the large number of lost-time injuries as well as the associated costs and suffering from ladder accidents justify increased training of the workforce and better supervision of ladder use. Worker training alone will not yield sufficient improvement. Any significant reduction in ladder accidents will require regular supervisory reinforcement of training as well as improved site control of operations involving ladders.

STANDARDS AND MATERIALS

Standard manufacturing specifications exist for most types of ladders. CSA Standard Z11 sets out standard requirements for manufacturing portable ladders. The Ontario Ministry of Labour has established standards for job-built wooden ladders, while the International Standards Organization has issued Standard ISO-2860 relating to “Access Ladders on Earth Moving Machinery”.

The most common materials for ladders are aluminum, wood, steel, and fiberglass-reinforced plastic.

Wooden ladders deteriorate more rapidly than those made of more durable materials. They must never be painted because paint hides signs of deterioration and may accelerate rotting by trapping moisture in the wood. However, they may be treated with a clear non-toxic wood

preservative or coated with a clear varnish. Inspect wooden ladders frequently for splits, shakes, or cracks in side rails and rungs; warping or loosening of rungs; loosening of attached metal hardware; and deformation of metal parts.

Although aluminum ladders are popular and more widely used than wooden ladders in construction, they are also more susceptible to damage by rough usage. Because they conduct electricity well, aluminum ladders must not be used where electrical contact is possible. Check side rails and rungs regularly for dents, bends, and loose rungs. If dented, the ladder should be taken out of service until repaired by a competent person. If repair is not possible, the ladder should be destroyed.

Fiberglass-reinforced plastic side rails are becoming more common and are generally used with aluminum rungs. They do not conduct electricity well and are resistant to corrosion. They are lightweight and available in various colours. They are, however, costly and heat-sensitive. They must not be exposed to temperatures above 93.3°C (200°F).

Fiberglass ladders should be inspected regularly for cracks and “blooming.” This condition is evidenced by tufts of exposed glass fiber where the mat has worn off. The worn area should be coated with an epoxy material compatible with the fiberglass.

Because of their weight, steel ladders are generally not used as portable ladders in the construction industry. They are, however, often fixed to permanent structures or mobile machinery.

TYPES

The many types of ladders used on construction sites range from metal ladders permanently mounted on equipment to job-built wooden ladders.

Portable Ladders (Figure 1)

All portable ladders must have non-slip feet or be set up so that the feet will not slip.

Portable ladders are available in various grades: light duty or grade 3; medium duty or grade 2; heavy duty or grade 1. The ladders may or may not be certified to CSA Standard Z11. For construction purposes, it is strongly recommended that only ladders bearing the CSA certification label be purchased and used. They may be slightly more expensive but CSA certification assures that the ladder has been manufactured to a high standard set by experts in ladder construction and use.

The type purchased should be compatible with the degree of rough usage expected. For general construction applications, heavy duty portable ladders are recommended. For certain types of finishing work, however, this degree of ruggedness may not be necessary and medium duty ladders will provide acceptable service. Where medium duty ladders are used, they should be restricted to the application for which they were manufactured and not “borrowed” for rougher service.

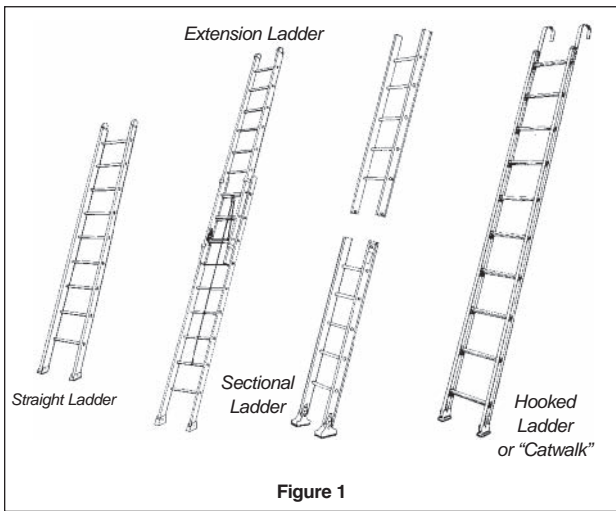


Figure 1

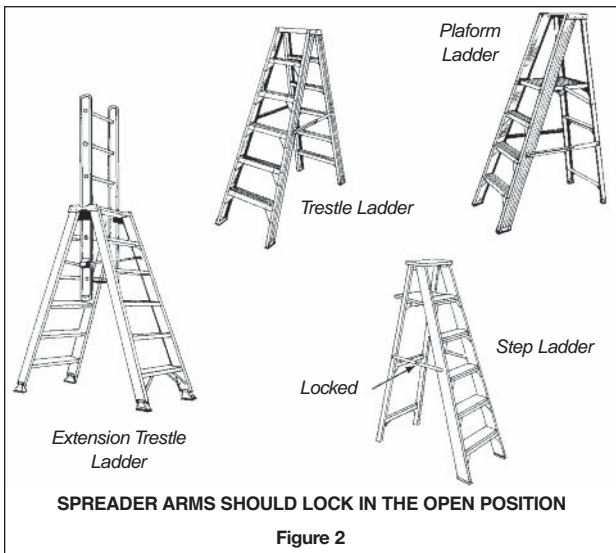


Figure 2

Step, Trestle and Platform Ladders (Figure 2)

Apart from the standards of sound construction and reliable service that should apply to all ladders used on site, the primary consideration with these ladders is that they have strong spreader arms which lock securely in the open position.

Fixed Ladders (Figure 3)

Steel ladders permanently fixed to structures such as stacks and silos are designed for service after construction is complete but are often used by work crews during construction. If the ladders are vertical and there is a risk of falling more than 3 metres (10 feet), a body harness and lifeline, or body harness and channel lock device, should be used by workers climbing up and down or working from the ladders. These ladders must have safety cages starting no more than 2.2 metres (7 feet) from the bottom of the ladder and extending at least 0.9 metres (3 feet) above the top landing. Rest platforms with ladder offsets are required at intervals no more than 9 metres (30 feet) apart where a fall-arrest system is not used. Vertical ladders permanently fixed to structures should comply with Ontario Ministry of Labour Engineering Data Sheet 2-04.

Special Purpose Ladders (Figure 4)

These ladders should be used in accordance with manufacturers' directions and only for the special applications intended.

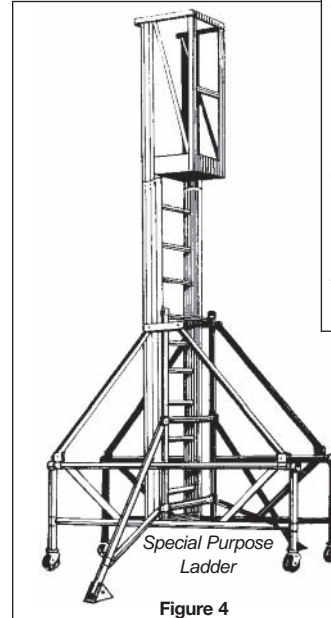


Figure 4

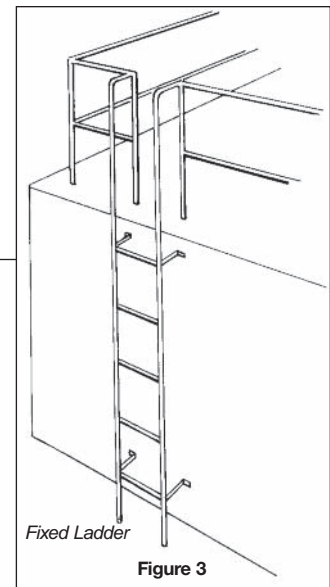
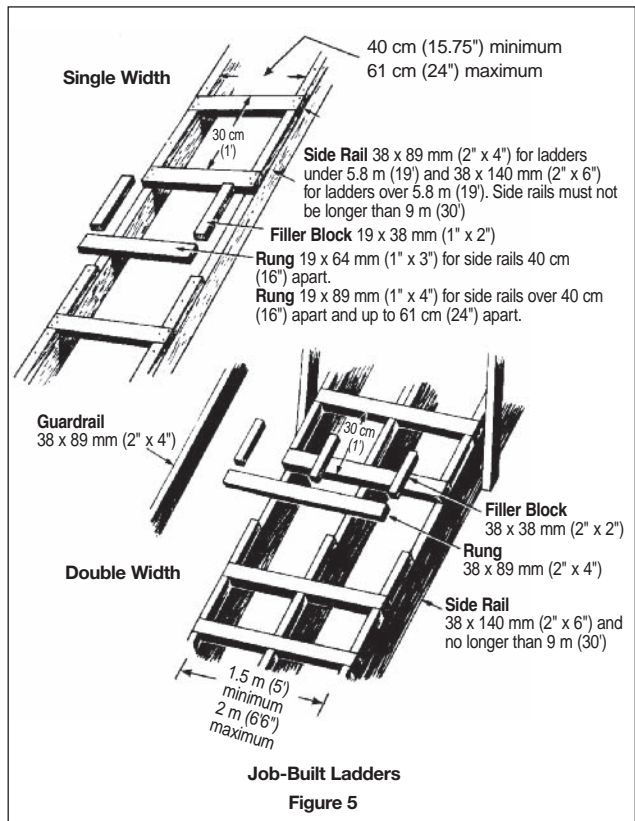


Figure 3

Job-Built Wooden Ladders (Figure 5)

Job-built ladders should be constructed according to good structural carpentry practice.

The wood should be straight-grained and free of loose knots, sharp edges, splinters, and shakes. Rungs should be clear, straight-grained, and free of knots. Job-built ladders must be placed on a firm footing and be securely fastened in position.



Remember — a wooden ladder should not be painted or coated with an opaque material.

A straight wooden ladder should not be longer than 9 metres (30 feet).

Job-built ladders are heavy and not recommended where portability is important. Because they are made of wood and often used by a whole crew of workers, job-built ladders deteriorate rapidly. They should be inspected every day or so. If defective, they must be repaired immediately or taken out of service and **destroyed**.

SUPERVISION AND USE

The Supervisor's Task

Ladder injuries can be significantly reduced by control of usage and improved site management. This requires that supervisory personnel

- train workers to maintain and use ladders properly
- evaluate the access requirements of a specific work assignment
- choose the best means of access for the job.

Because portable ladders are inherently hazardous, they should only be used where safer means of access such as stairs, scaffolds, manlifts, or ramps are not suitable or practical. Supervisors must consider the number of workers requiring access to elevated work locations as well as the extent and duration of the work before deciding on the safest and most economical means of access.

Ladders should not be used by large crews of workers. Basic considerations of efficiency usually indicate that other types of access such as stairs or even personnel hoists are much more suitable where significant numbers of workers are making repeated use of the access.

Where a significant amount of elevated work is to be performed by even one tradesman in an area, ladders are not recommended. Other types of access such as stationary or rolling scaffolds or powered elevating platforms will usually be more efficient and significantly reduce the potential for accidents.

In deciding on the best type of access for various tasks and work locations, management should also consider the amount of material involved; the time workers spend on the access equipment; weather conditions; equipment available on site; condition of surface from which access must be made; room available; potential for shared use with other trades, and so on. It is critical that consideration be given to worker access for specific tasks and for entire work areas. Ladders must not be used where other means of access are practical and safer.

If there is no practical alternative to ladders, supervisors should ensure that ladders are suitable and in good condition and personnel are trained to use them properly. Ladder stabilizers on straight and extension ladders are strongly recommended where ladders are the only means of access.

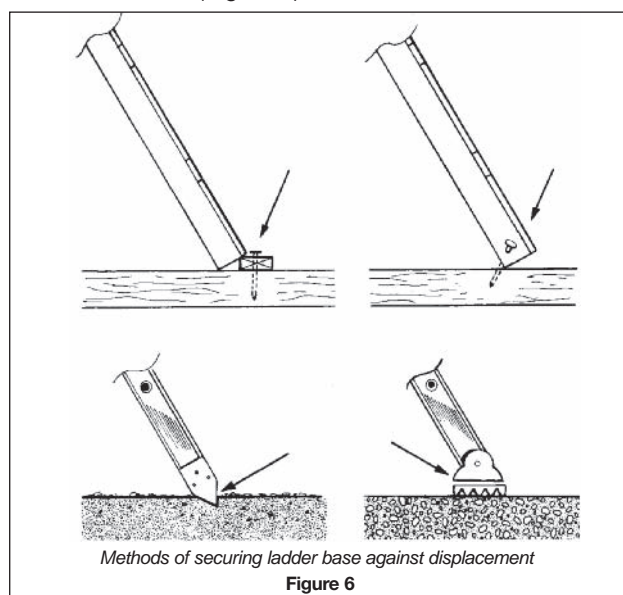
In addition to proper training, planning, and organizing for worker access, supervisory personnel must exercise control of all access situations. The supervisor must check that planning and directions are being carried out by workers. Although very important, the control function is often given insufficient attention by the busy supervisor. With ladders,

as with other supervisory responsibilities, details overlooked today can become problems tomorrow.

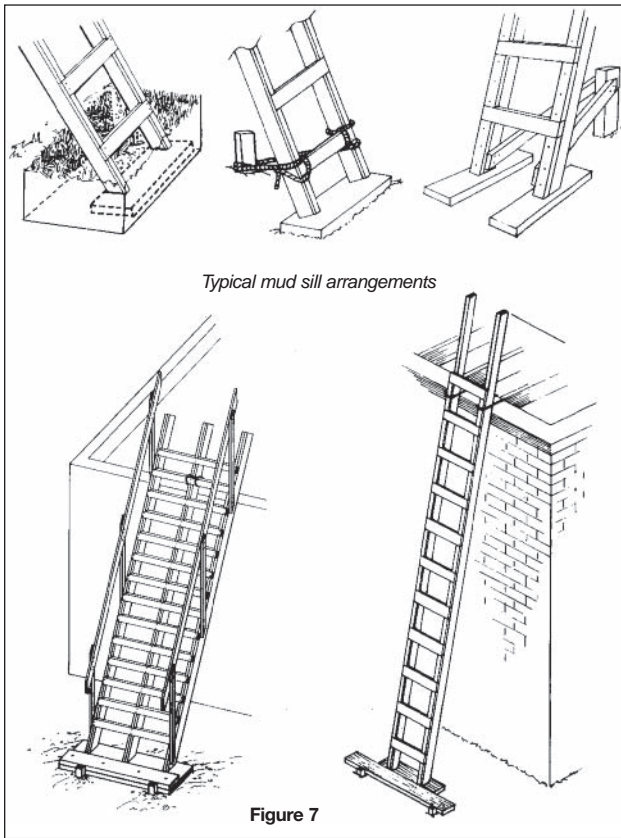
Proper Use of Ladders

More than 80 percent of ladder accidents are related to improper use or application of the equipment. Supervisors must control the application of equipment to particular situations. But personnel using the equipment must also be trained to use it. Training should include the following precautions.

- Check the ladder for defects at the start of a shift, after it has been used in another location by other workers, or after it has been left in one location for a lengthy period of time. (See the end of this chapter for inspection procedures.)
- Areas surrounding the base and top of the ladder should be clear of trash, materials and other obstructions since getting on and off the ladder is relatively more hazardous than other aspects of use.
- The base of the ladder should be secured against accidental movement. Use a ladder equipped with non-slip feet appropriate for the situation, nail a cleat to the floor, or otherwise anchor the feet or bottom of the side rails (Figure 6).



- The ladder must be set up on a firm level surface. If its base is to rest on soft, uncompacted or rough soil, a mud sill should be used (Figure 7).
- The top of the ladder should be tied off or otherwise secured to prevent any movement (Figure 8). If this is not possible, given the type of ladder or circumstances of its use, one worker should hold the base of the ladder while it is being used.
- If a ladder is used for access from one work level to another, the side rails should extend a minimum of 900 millimetres (3 feet) above the landing. Grab rails should be installed at the upper landing so that a worker getting on and off the ladder has secure handholds.
- All straight or extension ladders should be erected at an angle such that the horizontal distance between the top support and the base is not less than one-quarter or greater than one-third the vertical distance between these points (Figure 9).



Typical mud sill arrangements

Figure 7

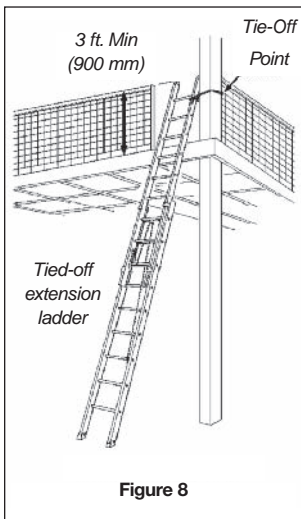


Figure 8

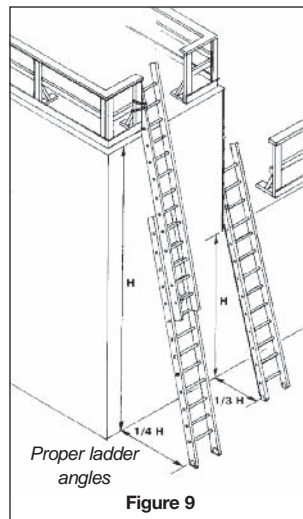


Figure 9

- Before setting up straight or extension ladders, check the area for overhead power lines. Ladders made of aluminum or other conductive material should never be used near power lines. Only competent electricians and linemen using ladders made of non-conductive material are allowed to work in close proximity to energized electrical lines.
- Portable ladders should never be used horizontally as substitutes for scaffold planks, runways, or any other service for which they have not been designed.
- When a task can only be done while standing on a portable ladder, the length of the ladder must be such that the worker stands on a rung no higher than the fourth from the top. The ladder should also be tied off or equipped with a suitable stabilizer.

- Short ladders must never be spliced together to make a longer ladder. Side rails will not be strong enough to support the extra loads.
- Straight ladders should not be used as bracing, skids, storage racks, or guys. They were not designed for these purposes and the damage caused by such abuse can later result in an accident during normal use.
- Unless suitable barricades have been erected, ladders should not be set up in passageways, doorways, driveways, or other locations where they can be struck or displaced by persons or vehicles using the access route.
- Only one person at a time should be allowed on a single-width ladder. In the case of a double-width ladder, no more than two people should be allowed on it at one time and each should be on a separate side.
- Ladders should not be placed against flexible or movable surfaces.
- Always face the ladder when climbing up or down and when working from it.
- Maintain 3-point contact when climbing up or down a ladder. That means two hands and one foot or two feet and one hand on the ladder at all times. This is especially important when you get on or off a ladder at heights (Figure 10).

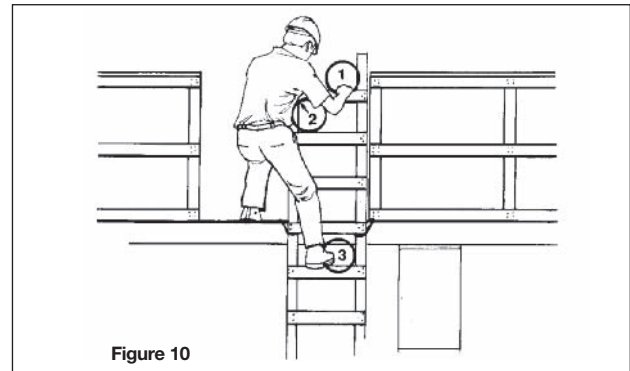
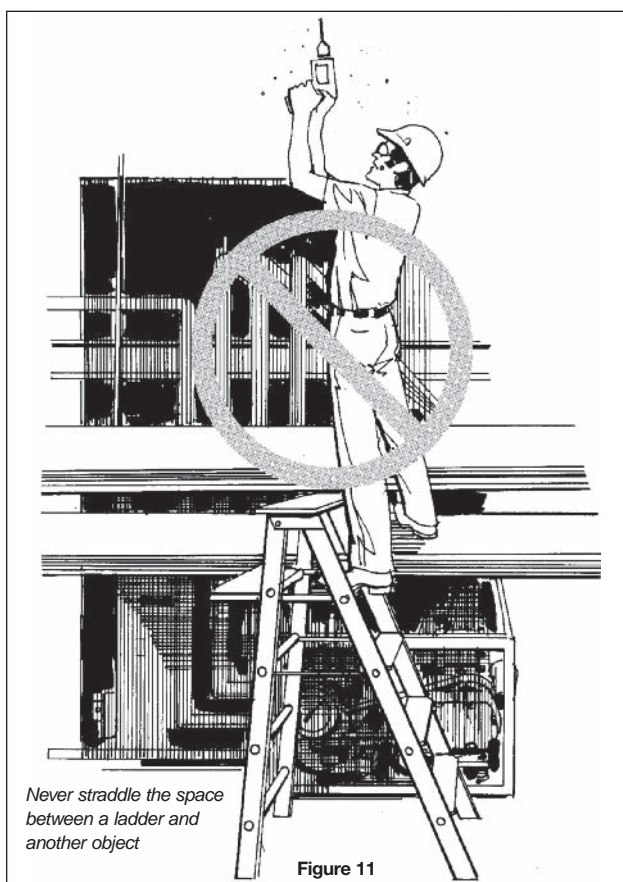


Figure 10

- When working from a ladder, keep your centre of gravity between the side rails. A person's centre of gravity is approximately in the centre of the body at belt height. The location of your centre of gravity can shift when you reach out to either side of a ladder, especially with materials, tools, or equipment in your hands. As the centre of gravity of your body and hand-held objects moves beyond the side rails, the ladder is tending toward instability.
- Whenever possible, avoid climbing up or down a ladder while carrying anything in your hands. Tools, equipment and materials should be placed in a container and raised or lowered by rope, if necessary.
- Workers should be instructed and frequently reminded to keep their boots free of mud, snow, grease, or other slippery materials if they are using ladders.
- Always hold onto the ladder with at least one hand. If this is not possible because of the task to be done and in particular if the work is 3 metres (10 feet) or more above the floor, the worker must wear a safety harness and tie the lanyard off to the structure or to a lifeline before beginning work.
- Never straddle the space between a ladder and another object (Figure 11).



- Persons frequently required to use or work from ladders should wear protective footwear with soles and heels made of slip-resistant materials such as soft urethane.
- Never erect ladders on boxes, carts, tables, or other unstable surfaces.
- Fall-arresting equipment such as ladder climbing devices or lifelines should be used when working from long fixed ladders or when climbing vertical fixed ladders.
- Never rest a ladder on any of its rungs. Ladders must rest on their side rails.
- When erecting long, awkward, or heavy ladders, two or more persons should share the task to avoid injury from over-exertion.
- Instruct all personnel to watch for overhead power lines before attempting to erect any ladder. When overhead power lines are in proximity of the work, aluminum ladders must not be used.

INSPECTION AND MAINTENANCE

Regular inspection and maintenance will increase the useful life of ladders and reduce the number of accidents. A suggested checklist for inspection has been provided at the end of this chapter. Repairs should only be carried out by someone competent and familiar with this kind of work.

Ladders found to be defective should be taken out of service and either tagged for repair or scrapped. Once tagged, the ladder must not be used until repaired. Ideally, the tag should only be removed by the person who took the ladder out of service initially. The tag should be printed in big bold letters with the words "DANGER – DO NOT USE".

General Procedures

Ladders should be inspected for structural rigidity. All joints between fixed parts should be tight and secure. Hardware and fittings should be securely attached and free of damage, excessive wear, and corrosion. Movable parts should operate freely without binding or excessive play. This is especially important for gravity-action ladder locks on extension ladders.

Non-skid feet should be checked for wear, imbedded material, and proper pivot action on swivel feet.

Deteriorated, frayed or worn ropes on extension ladders should be replaced with a size and type equal to the manufacturer's original rope.

Aluminum ladders should be checked for dents and bends in side rails, steps, and rungs. Repairs should be made only by the manufacturer or someone skilled in good aluminum or metal work practices. Replacing a rung with a piece of conduit or pipe is not good practice and should not be permitted.

Wooden ladders are susceptible to cracking, splitting, and rot and should be either unpainted or covered with a transparent finish in order that checks, cracks, splits, rot, or compression failures can be readily detected. Repairs should be consistent with good woodworking practice. Only wood equal to or better than the wood used by the manufacturer should be used in the repair.

The bases, rungs, and steps of all ladders should be examined for grease, oil, caulking, imbedded stone and metal, or other materials that could make them slippery or otherwise unsafe.

Methods of storage and transportation are important. Storage areas should permit easy access and be cool and dry, particularly if wooden ladders are kept there. Areas where the moving of other materials can damage ladders should be avoided. Ladders should be supported during storage and transportation to prevent sagging or chafing. When being transported, ladders should be "top freight" — nothing should be piled on them. If damage does occur, the condition causing the damage should be corrected as well as having the ladder repaired.

Special Considerations

All trades have frequent ladder accidents. To improve accident prevention, supervisors should devote more time to training and reinforcement of training on the job.

Approximately 50 percent of all ladder accidents occur while tasks are being performed from the ladder. Many of these accidents could be prevented by using other types of access equipment such as scaffolds or powered elevating platforms.

Between 30 and 40 percent of all ladder accidents involve unexplained loss of footing. Because inattention may be a cause, training should be strengthened to maintain awareness of the hazards involved in working from ladders.

Many ladder accidents are related to unfavourable weather conditions such as wind, mud, ice, snow, and rain which create slippery and unstable situations. This is an especially important consideration for the outside trades

such as labourers, bricklayers, sheet metal applicators, roofers, and carpenters.

A surprising number of accidents occur when workers take the first step onto the bottom rung of a ladder. While falls from this distance are usually not as serious as those from greater heights, they nevertheless create injuries such as sprains, strains, fractures, and contusions that often result in lost-time claims. Workers should be advised to be careful when stepping onto any ladder. It is often at this point that the unstable, insecure ladder will slide or tip and that muddy or snow-covered boots will slip on the first or second rung. Make sure that boots are clean, that ladders are secure and stable, and that workers are aware of the hazards. Again, this involves supervisor training and continuous reinforcement.

Finally, a large number of accidents occur because workers use straight ladders that are not secured. Site supervisors must rigidly ensure that ladders are either firmly secured (Figures 6-8) or held in place by a second worker.

LADDER USE CHECKLIST

DO

- Familiarize personnel with your ladder safety policy.
- Use a ladder properly suited to the task.
- Construct job-built ladders properly.
- Inspect ladders before use.
- Erect ladders with the proper slope (between 4:1 and 3:1).
- Avoid placing ladders in areas with high traffic or activity such as walkways, entrances, and exits.
- Tie ladders off at the top.
- Block or otherwise secure the ladder base or have the ladder held by a second worker when in use.
- When outdoors, place the ladder base on firm footings such as compacted soil or mudsills.
- Extend the ladder 900 mm (3 feet) above the top landing.
- Clear material, debris, and other obstructions from the top and bottom of ladders.

WHEN CLIMBING

- Use a single-width ladder one person at a time only.
- Maintain three-point contact.
- Do not carry anything in your hands.
- Face the ladder.
- Use a fall-arrest system on long ladders.

DO NOT

- use ladders when a safer means of access is available and practical.
- use metal ladders near live electrical equipment or conductors.
- use ladders horizontally or for some other purpose for which they haven't been designed.
- damage ladders during transport and storage.
- support ladders on their rungs.
- erect long or heavy ladders by yourself.

LADDER INSPECTION CHECKLIST

	YES	NO
1. Are any wooden parts splintered?	<input type="checkbox"/>	<input type="checkbox"/>
2. Are there any defects in side rails, rungs, or other similar parts?	<input type="checkbox"/>	<input type="checkbox"/>
3. Are there any missing or broken rungs?	<input type="checkbox"/>	<input type="checkbox"/>
4. Are there any broken, split, or cracked rails repaired with wire, sheet metal, or other makeshift materials?	<input type="checkbox"/>	<input type="checkbox"/>
5. Are there any worn, damaged, or missing feet?	<input type="checkbox"/>	<input type="checkbox"/>
6. Are there any worn, damaged, or unworkable extension ladder locks, pulleys, or other similar fittings?	<input type="checkbox"/>	<input type="checkbox"/>
7. Is the rope on extension ladders worn, broken, or frayed?	<input type="checkbox"/>	<input type="checkbox"/>
8. Has the rope on extension ladders been replaced by material inferior to the ladder manufacturer's original rope?	<input type="checkbox"/>	<input type="checkbox"/>
9. Are the spreader arms on step ladders bent, worn, broken, or otherwise rendered partly or totally ineffective?	<input type="checkbox"/>	<input type="checkbox"/>

If the answer is "YES" to any of the questions on the Inspection Checklist, the ladder should be tagged so that workers will know it is defective and should not be used. It should be taken out of service immediately and placed in a location where it will not be used until repairs are completed. If the ladder is not to be repaired it should be destroyed.

21 SCAFFOLDS

Contents

1. Introduction
2. Problem areas
3. Selection
4. Basic types of scaffolds
5. Scaffold components
6. Erecting and dismantling scaffolds
7. Scaffold stability
8. Platforms
9. Proper use of scaffolds

1 INTRODUCTION

More than half of scaffold accidents in Ontario construction are falls. Several fatalities are also related to scaffolds each year. The number and severity of injuries involved make scaffold accidents one of the more serious safety problems in construction.

2 PROBLEM AREAS

The main problem areas are

- erecting and dismantling scaffolds
- climbing up and down scaffolds
- planks sliding off or breaking
- improper loading or overloading
- platforms not fully planked or “decked”
- platforms without guardrails
- failure to install all required components such as base plates, connections, and braces
- moving rolling scaffolds in the vicinity of overhead electrical wires
- moving rolling scaffolds with workers on the platform.

2.1 Erecting and Dismantling

From 15 to 20% of scaffold-related injuries involve erecting and dismantling. The most common problem is the failure to provide an adequate working platform for a worker to use when installing the next lift of scaffold. Working from one or two planks is not recommended.

The next important consideration involves components, such as tie-ins, which you should install as the assembly progresses. Failure to do so makes the scaffold less stable and, while it may not topple, it may sway or move enough to knock someone off the platform. This happens more often when platforms are only one or two planks wide and guardrails are missing, as is frequently the case during erection and dismantling.

2.2 Climbing Up and Down

Approximately 15% of scaffold-related injuries occur when workers are climbing up and down. Climbing up and down frames is a common but unacceptable practice that has resulted in numerous injuries and fatalities. Climbing up and down braces is also a frequent cause of accidents. You must provide adequate ladders to overcome this problem. In addition, workers must use proper climbing techniques (three-point contact).

2.3 Planks Sliding Off or Breaking

Many scaffold injuries involve problems with planks. If scaffold planks are uncleaned or otherwise unsecured they easily slide off – this causes a surprising number of injuries. Scaffold planks can also break if they are in poor condition or overloaded. It is therefore important to use proper grades of lumber and to inspect planks before erection to ensure that there are no weak areas, deterioration, or cracks. Another common problem is insufficient or excessive overhang of planks at their support. Excessive overhang can cause a plank to tip up when a worker stands on the overhanging portion. Insufficient overhang is a leading cause of planks slipping off.

2.4 Improper Loading or Overloading

Overloading causes excessive deflection in planks and can lead to deterioration and breaking. Overloading occurs most often in the masonry trade where skids of material can exceed 1500 kg (3000 lb.). If material is left overhanging the scaffold platform it can cause an imbalance leading to the scaffold overturning.

2.5 Platforms Not Fully Decked

This situation is related to injuries not only during erection and dismantling but in general scaffold use. The Construction Regulation (Ontario Regulation 213/91) requires that all scaffold platforms must be at least 450 mm (18 inches) wide. All platforms above 2.4 metres (8 feet) must be fully decked.

2.6 Platforms without Guardrails

Platforms without guardrails are a serious safety problem in construction. Guardrails are an important fall prevention measure not only for high platforms but also for low ones. Over one-third of the falls from scaffolds are from platforms less than 3 metres (10 feet) in height. Therefore, guardrails are recommended during normal use for all scaffold platforms over 1.5 metres (5 feet) high. Guardrails for all working platforms should consist of a top rail, a mid-rail, and a toeboard.

2.7 Failure to Install All Required Components

Failure to use all of the proper scaffold components is a serious safety problem. Workers are more likely to cut corners when scaffolds are only a few frames in height. All too frequently they fail to install base plates, braces, proper securing devices such as “banana” clips or “pig tails” at the pins of frame scaffolds, and adequate tie-ins. Those erecting the scaffold must have all the necessary components, and must use them to ensure that the scaffold is safe. Furthermore, workers should install these parts as the scaffold erection progresses.

2.8 Electrical Contact with Overhead Wires

Scaffolds seldom make contact with overhead electrical lines, but when it does happen it almost always results in a fatality. Failure to maintain safe distances from overhead powerlines while moving scaffolds is a major problem. Before attempting to move rolling scaffolds in outdoor open areas, check the route carefully to ensure that no overhead wires are in the immediate vicinity. Partial dismantling may be necessary in some situations to ensure that the scaffold will make the required safe

clearances from overhead powerlines. The required minimum safe distances are listed in Table 1. Hoisting scaffold material by forklift or other mechanical means requires careful planning and should be avoided in the vicinity of powerlines. Transporting already-erected scaffolds by forklift, particularly in residential construction, has been the cause of many electrical contacts — this is a dangerous practice. Workers handling materials or equipment while working on the platform must also take care to avoid electrical contact.

Table 1: Minimum distance from powerlines

Voltage Rating of Power Line	Minimum Distance
750 to 150,000 volts	3 metres (10 feet)
150,001 to 250,000 volts	4.5 metres (15 feet)
over 250,000 volts	6 metres (20 feet)

2.9 Moving Rolling Scaffolds with Workers on the Platform

Moving rolling scaffolds with workers on the platform can be dangerous. Where it is impractical for workers to climb down, and the scaffold is over 3 metres (10 feet) in height, each worker must be tied off with a full body harness and lanyard. Lifelines must be attached to a suitable anchor point other than the scaffold. Holes, depressions, curbs, etc. have all been responsible for scaffolds overturning while being moved. In some jurisdictions moving a scaffold with workers on the platform is prohibited if the platform exceeds a certain height.

3 SELECTION

The safe and efficient use of scaffolding depends first on choosing the right system for the job. If the scaffold's basic characteristics are unsuited to the task, or if all the necessary components are not available, personnel are forced to make do and improvise. These conditions lead to accidents.

Proper selection of scaffolding and related components requires basic knowledge about site conditions and the work to be done. Considerations include

- weight of workers, tools, materials, and equipment to be carried by the scaffold
- site conditions (e.g., interior, exterior, backfill, concrete floors, type and condition of walls, access for the equipment, variations in elevation, anchorage points)
- height or heights to which the scaffold may be erected
- type of work that will be done from the scaffold (e.g., masonry work, sandblasting, painting, metal siding, mechanical installation, suspended ceiling installation)
- duration of work
- experience of the supervisor and crew with the types of scaffolds available
- requirements for pedestrian traffic through and under the scaffold
- anticipated weather conditions
- ladders or other access to the platform
- obstructions
- configuration of the building or structure being worked on
- special erection or dismantling problems including providing practical fall protection for the erector

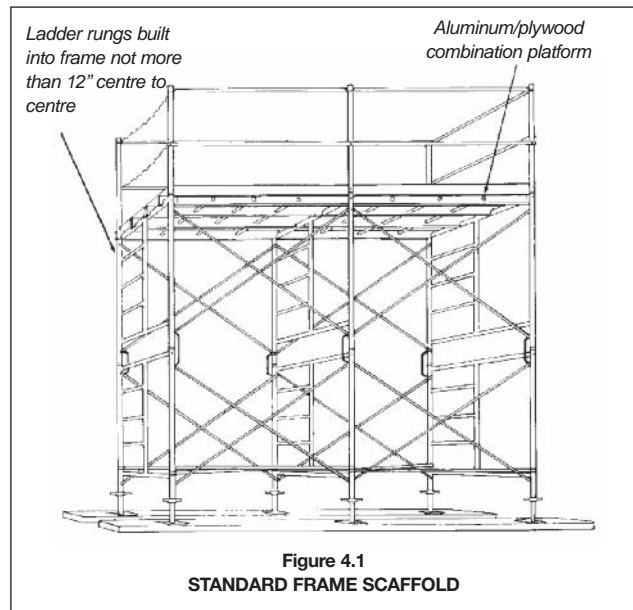
- the use of mechanical equipment to aid in erecting the scaffold.

4 BASIC TYPES OF SCAFFOLDS

4.1 Standard Tubular Frame Scaffolds

This is the most frequently used scaffold in construction. Historically it has been made of steel tubing, but aluminum is gaining popularity. The scaffold is manufactured in various configurations and spans. On some systems, ladder rungs are built into the end frames (Figure 4.1). These ladders are not suitable for tall scaffold towers unless rest platforms are installed at regular intervals and trapdoors are provided in the platforms. Other models are equipped with ladders that attach to the end frames (Figure 4.3). The ladder shown in Figure 4.3 is continuous and workers gain access via gates at the platform level. Again this ladder is not suitable for high scaffolds. Scaffolds in excess of 9 metres (30 feet) should have built-in stairs with rest platforms. Vertical ladders can reach up to 9 metres, but above 2.2 metres (7 feet) they require a safety cage.

The advantages of the frame scaffold are that it is simple to assemble, many construction trades are familiar with its use, and the components can be lifted manually by workers. However, as with other systems, all parts must be used. Failure to install any of the components, such as bracing and base plates, may lead to accidents.



4.2 Standard Walk-through Frame Scaffolds

This is a variation of the standard tubular frame scaffold. An example is shown in Figure 4.2. Although primarily designed to accommodate pedestrian traffic at the ground or street level, the walk-through scaffold is frequently used by the masonry trade to provide greater height per tier and easier distribution of materials on platforms at intermediate levels.

4.2.1 Spans of Tower Base

Span lengths are varied using different lengths of vertical bracing. Most manufacturers have braces providing spans between 5 and 10 feet in length, with 7-foot spans being the most common. The use of 7-foot spans is ideal when using 16-foot planks as this allows a 1-foot overhang at each end. When using spans in excess of 7 feet, the load-bearing capacity of the platforms is reduced and must be accounted for in the design.

Note: Walk-through frame allows easier distribution of materials

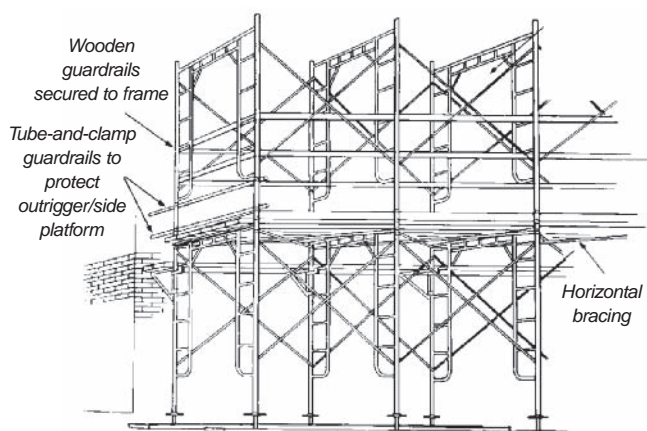


Figure 4.2
WALK-THROUGH SCAFFOLD

4.3 Rolling Scaffolds

Rolling scaffolds are best suited where short-duration work must be carried out at multiple locations. They are used mainly by mechanical and electrical trades. There are two main types of rolling scaffold.

- **Castor Type.** This type of scaffold is best suited for work on smooth floors and is typically used inside buildings. All castors should be equipped with braking devices (Figure 4.3). This kind of scaffold should be erected so that its height-to-width ratio is no greater than 3 to 1. This limits the height of platforms with standard outrigger stabilizers and single span towers to approximately 9 metres (30 feet).
- **Farm Wagon Type.** Scaffolds erected on farm wagons or other devices with pneumatic tires are frequently used for installing sheet metal siding and similar materials on industrial buildings. For safe, effective use, the area around the building should be well compacted, relatively smooth and level. This type of scaffold must also have outrigger beams with levelling devices (Figure 4.4). It is subject to the 3-to-1 height-to-width ratio and is impractical for heights greater than 7.5 metres (25 feet). The scaffold should always be resting on the outriggers while workers are aboard. It should never be used as a work platform while it is "on rubber."

Rolling scaffolds other than those that are lifted off the ground on outriggers should have brakes on all wheels. All brakes should be applied when the scaffold reaches the desired location.

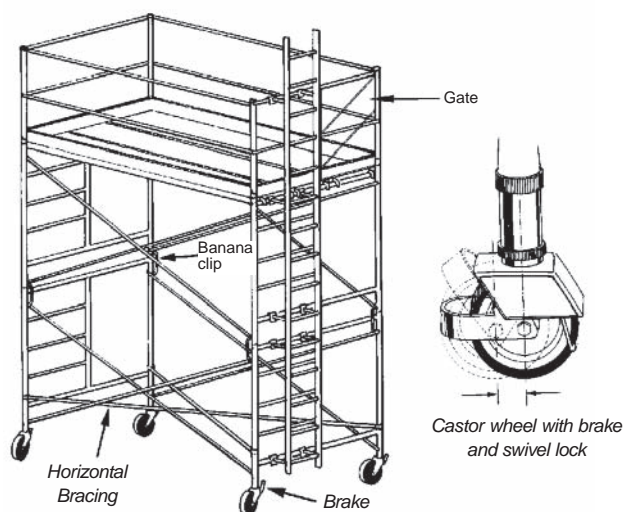


Figure 4.3
ROLLING SCAFFOLD

NOTE: Screw jacks should be adjusted to lift wheels off ground before workers mount the scaffold.

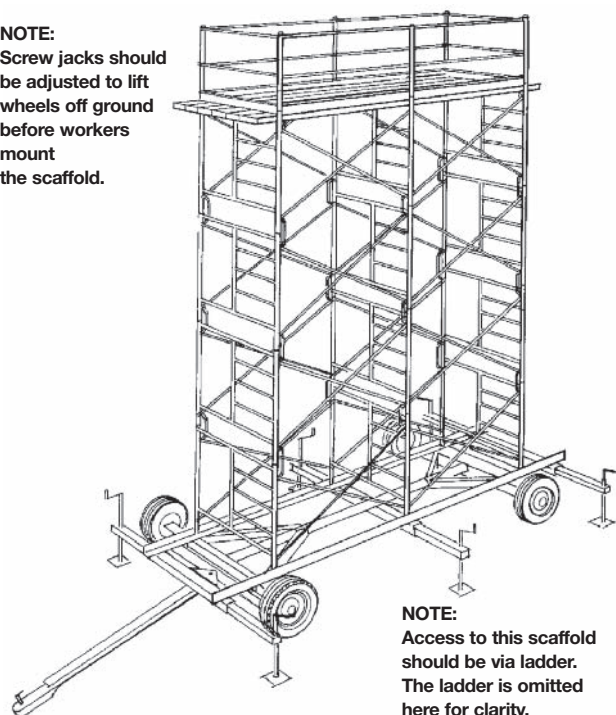


Figure 4.4
FARM WAGON ROLLING SCAFFOLD

It is best not to move rolling scaffolds while a worker is on the platform. If people must remain on the platform when the scaffold is being moved they should be tied off to an independent structure using a fall-arrest system. In some jurisdictions moving a scaffold with workers on the platform is prohibited if the scaffold exceeds a certain height. The area through which the scaffold is to be moved should be free of bumps or depressions and cleared of all debris. Overhead hazards, especially powerlines, should be identified.

Rolling scaffolds should always have guardrails. They should also be securely pinned together and be fitted with horizontal bracing as recommended by the manufacturer.

Scaffolds that are not securely pinned together can separate if they drop into a hole or depression, or run into an obstacle at ground level. Horizontal bracing is necessary on a rolling tower scaffold to keep it from folding up because the connections between frames and braces are essentially pinned joints.

Castors should be secured to the frame. A castor dropping off in a hole or depression in floors has been the cause of serious accidents and injuries. Each castor should have a brake and swivel lock which are in good working order and can be applied easily. The castors or wheels should be suitable for the surface on which the scaffold is being used. Small wheels are suitable for pavement or concrete floors. You need larger pneumatic wheels when soils are the working surface. Before using rolling scaffolds, the surface must be smooth, free of depressions and reasonably level.

4.3.1 Electrical Contact

One of the biggest concerns with rolling scaffolds is the possibility of contact with overhead electrical wires. Scaffolds making accidental contact with powerlines have caused many deaths. Before moving a rolling scaffold, check the intended path of travel and maintain the required minimum clearances as set out in Table 1.

4.4 Fold-up Scaffold Frames

Fold-up scaffold frames (Figure 4.5) are frequently used by trades such as electricians, painters, and suspended ceiling erectors. Widths range from dimensions that will pass through a 750-mm (30-inch) opening to the standard width of about 1.5 metres (5 feet). Frequently made of aluminum, this type of scaffold is easily and quickly transported, erected, and moved about construction sites and from job to job. It should be used only on a smooth, hard surface.

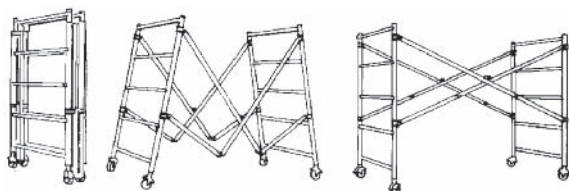


Figure 4.5
FOLD-UP SCAFFOLD

4.5 Adjustable Scaffolds

Figure 4.6 illustrates another type of scaffold with uses similar to the fold-up model. Although it is not so easily erected, the system is light and very easily adjusted for height. It breaks down into a minimum of components readily transported from job to job. These devices should also be used only on smooth, hard surfaces. They are not intended to carry heavy loads.

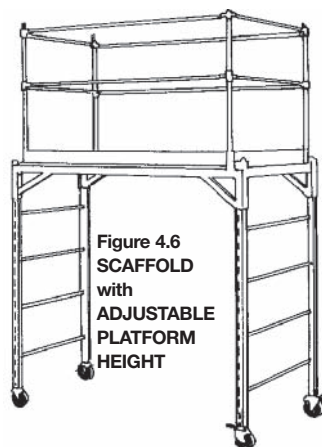


Figure 4.6
SCAFFOLD
with
ADJUSTABLE
PLATFORM
HEIGHT

4.6 Tube-and-Clamp Scaffolds

Tube-and-clamp scaffolds (Figure 4.7) are frequently used where obstructions or non-rectangular structures are encountered. The scaffolds are infinitely adjustable in height and width. They can also be used for irregular and circular vertical configurations.

Personnel erecting tube-and-clamp scaffolds must be experienced. It is strongly recommended that, for each application, a sketch or drawing be prepared by someone who understands general structural design and the need for diagonal and cross bracing. In general, this type of scaffold takes longer to erect than the standard tubular frame type. Tube-and-clamp scaffolds above 10 metres (33 feet) must be designed by a professional engineer.

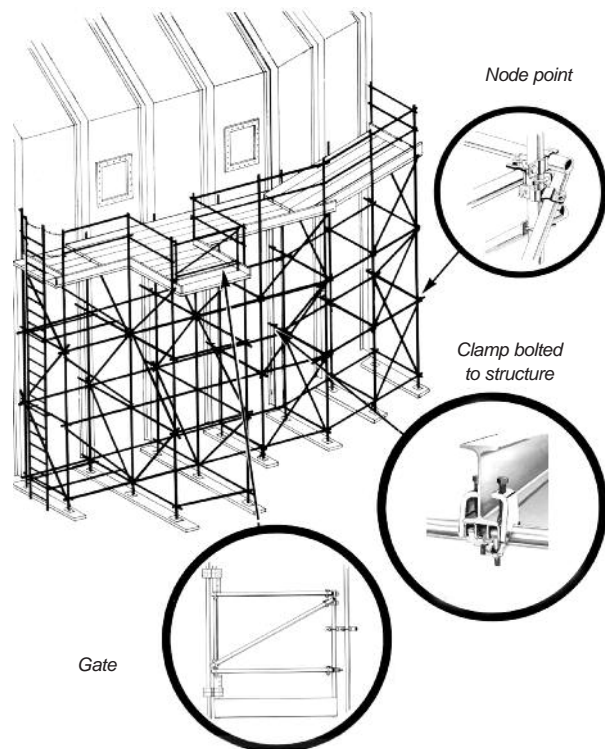


Figure 4.7
TUBE-AND-CLAMP SCAFFOLD

4.7 Systems Scaffolds

European scaffold systems have become very popular in applications that were traditionally suited to tube-and-clamp. Although they are not as adjustable as tube-and-clamp scaffolds, they can be applied to a wide variety of non-rectangular, circular, or dome-shaped structures. A typical example is shown in Figure 4.8. As with tube-and-clamp scaffolds, personnel carrying out the erection should be experienced with that type of system and a sketch or drawing of the scaffold to be erected is recommended for each application. Systems scaffolds above 10 metres (33 feet) in height must be designed by a professional engineer.

There are a great many systems available, ranging from light-duty aluminum to heavy-duty steel support structures. They all employ different patented locking devices (wedges, locking pins, etc.) which are not intended to be interchanged with other systems.

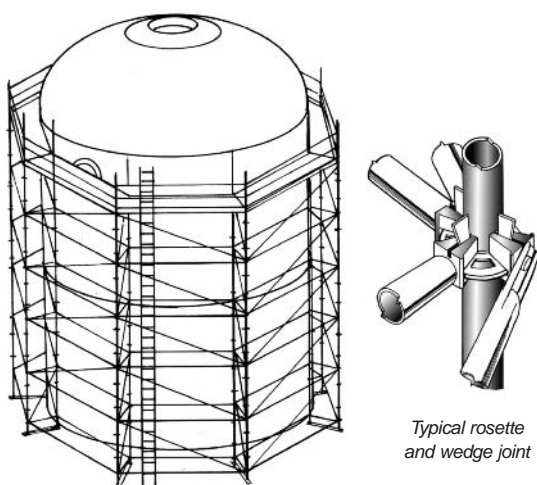


Figure 4.8
SYSTEMS SCAFFOLD

4.8 Mast-Climbing Work Platforms

The use of mast-climbing work platforms (Figure 4.9) is becoming increasingly common, particularly in the masonry industry. They are best suited for medium to high-rise projects, and are used also by siding installers, window installers, drywallers, and other trades. For low to medium-height projects they can be freestanding, depending on ground conditions and manufacturers' instructions. For high-rise applications they can be tied to the structure at regular intervals as set out by the manufacturer.

Mast-climbing work platforms can be used as a single tower or as multiple towers braced together. The platform climbs the mast, normally powered by an electric or gas engine. The climbing mechanism will have a failsafe system to prevent accidental lowering or failing of the platform.

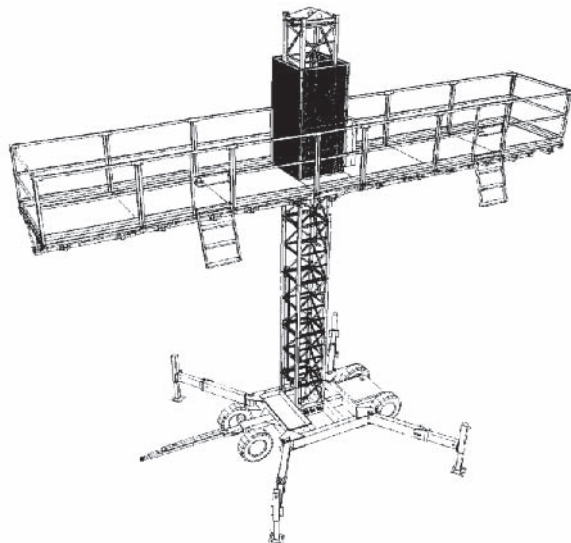


Figure 4.9
MAST-CLIMBING WORK PLATFORM

Although not shown here, the working platform can be a set distance below the material platform. This allows material to be stacked at a convenient height for the worker. The entire platform can be raised to whatever height is required. As such it has significant ergonomic advantages.

Engineered drawings should accompany this work platform outlining such components as load capacity, tie-in requirements, and bracing.

The potential for fall-related accidents is reduced when using mast-climbing work platforms since workers stay on a wide, secured platform even during erection and dismantling.

Manufacturers' instructions must be followed at all times. A competent worker should supervise the erection.

4.9 Crank-up or Tower Scaffolds

Although crank-up scaffolds (Figure 4.10) are more popular in the United States, some Canadian masonry contractors use them. They consist of towers, bases, and platforms that can be lifted by winches.

The working platform is located 600 to 900 mm (2 to 3 feet) below the material platform, which is in an ergonomically good position for the worker.

The entire scaffold can be raised easily, allowing the worker a comfortable working height. Crews must be trained to erect, use, dismantle, and maintain tower scaffolding safely and efficiently. **Manufacturers' instructions must be followed at all times.** Tower scaffolds must be tied to the structure according to manufacturer's instructions.

5 SCAFFOLD COMPONENTS

Tubular Frame Scaffolds: There are many tubular frame scaffold components available (Figures 5.1, 5.2). Some components are necessary in almost all situations; others are optional depending on use and manufacturers' instructions. In addition to scaffold end frames, the minimum components required are

- base plates or castors
- mudsills
- adjustable screw jacks
- vertical braces on both sides of frames unless

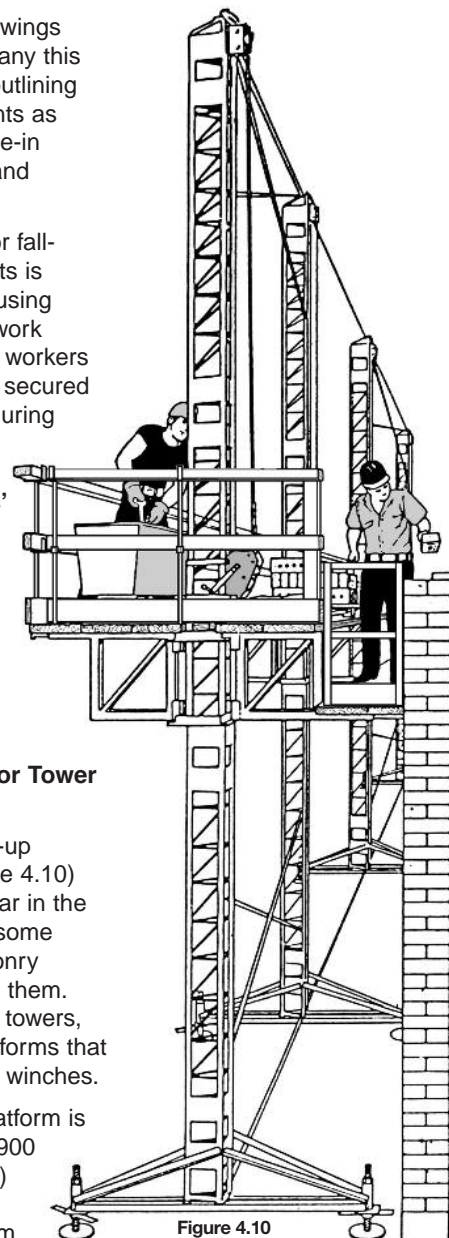
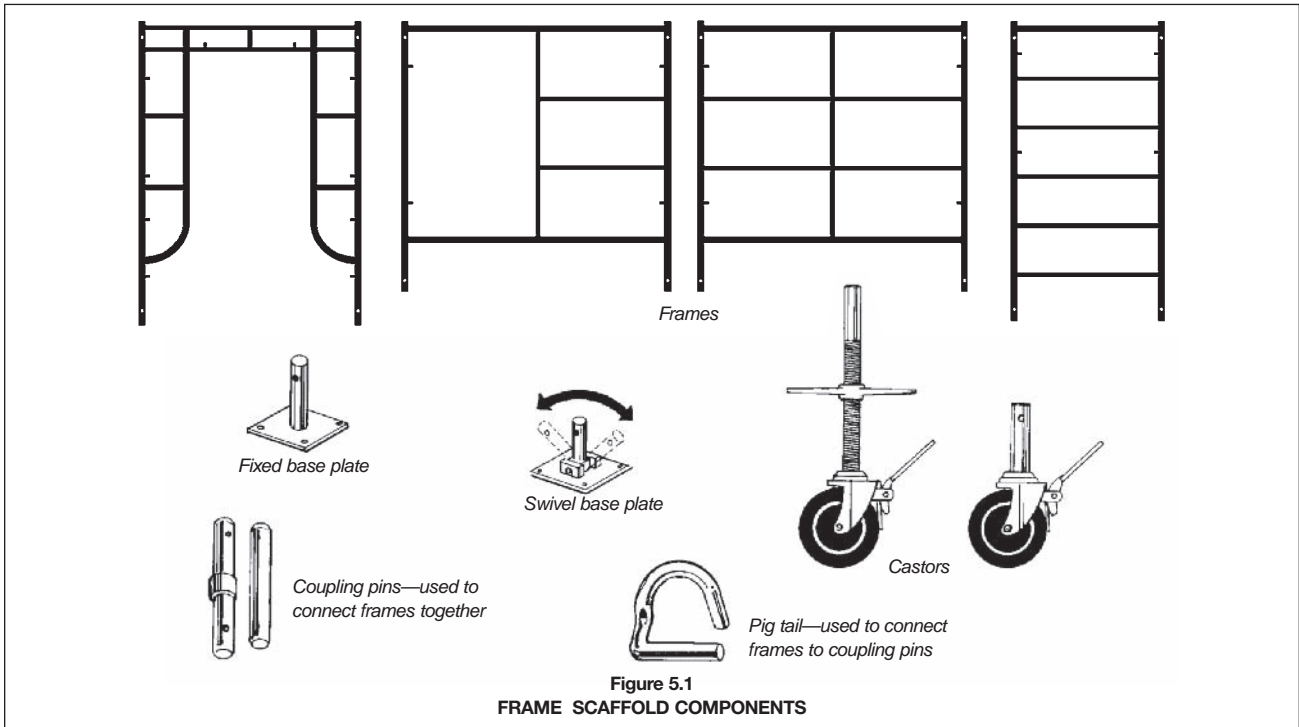
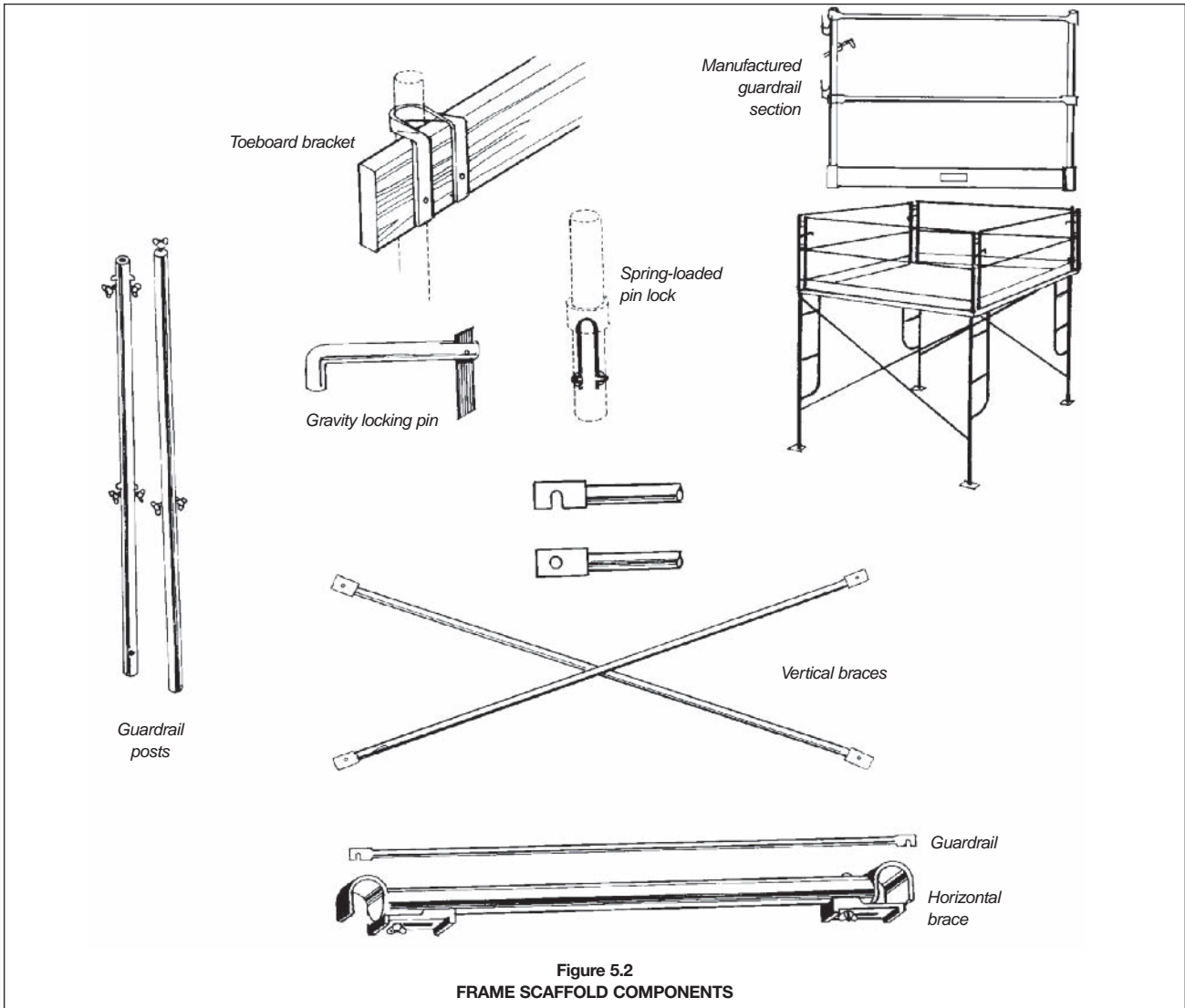


Figure 4.10
TOWER SCAFFOLD



**Figure 5.1
FRAME SCAFFOLD COMPONENTS**



**Figure 5.2
FRAME SCAFFOLD COMPONENTS**

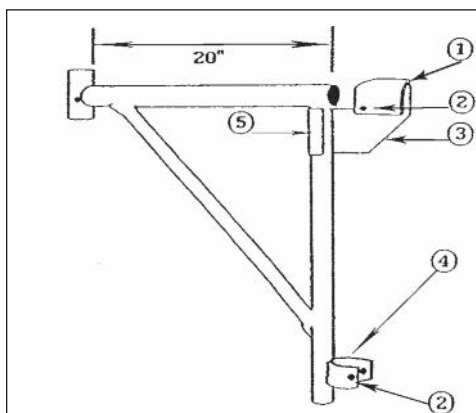


Figure 5.3 - Outrigger / Side Bracket

When purchasing outrigger/side brackets, look for the following features, numbered to correspond with Figure 5.3.

1. Hook tops out at a V-point to sit securely on varying diameters of horizontal frame members
2. Hook and bottom shoe are prepared to receive pin
3. Hook is heavy-gauge, fabricated from one piece of steel
4. Ensure that the lower shoe won't interfere with braces, locks, or other features of different manufacturer's frames
5. Hook plate is wrapped around vertical member and welded on three sides only

- frames are designed with “non-pinned” joints
 - additional bracing is provided by a designed system using tube-and-clamp accessories
- horizontal braces on every third tier of frames
 - platform materials to fully deck in the intended working level
 - guardrails complete with toeboards
 - guardrail posts where working platforms will be at the top level
 - ladders or stairs for access
 - intermediate platforms where required—not more than 9 metres (30 feet) apart and adjacent to vertical ladders.

Tube-and-Clamp Scaffolds and Systems Scaffolds have individual components unique to each type. These components are identified and discussed in detail in Section 6.

5.1 Platforms

Platforms for frame scaffolds are normally either aluminum/plywood platforms or wood planks. Planks normally come in 8-foot or 16-foot lengths to cover one or two 7-foot bays with adequate overhang. Platforms are dealt with in depth in Section 8.

5.2 Outrigger/Side Brackets

The use of outrigger brackets—also known as side brackets (Figure 5.3)—is very popular in the masonry industry. They are attached to the inside of the frame and accommodate a platform approximately 20" (two planks) wide. They provide a work platform for the mason at an ergonomically convenient location, lower than the material platform. Intended as a work platform only, they are not to be used for material storage.

Instances have been reported of brackets installed on the “wrong” side of the scaffold—facing the forklift, for example, to provide a landing area for skids of material. This is not acceptable because outrigger brackets are not designed for supporting material. Furthermore, the practice may lead to unbalanced loading of the scaffold, causing tip-over.

Figure 5.4 illustrates typical outrigger/side brackets attached to the scaffold for masonry use. For efficient, comfortable work, the brackets should be adjustable in lifts of no more than 600 mm (24 inches). A space no greater than 150 mm (6 inches) should be maintained between the bracket platform and the wall. Although the outrigger brackets illustrated are side brackets, end brackets are also available from most manufacturers.

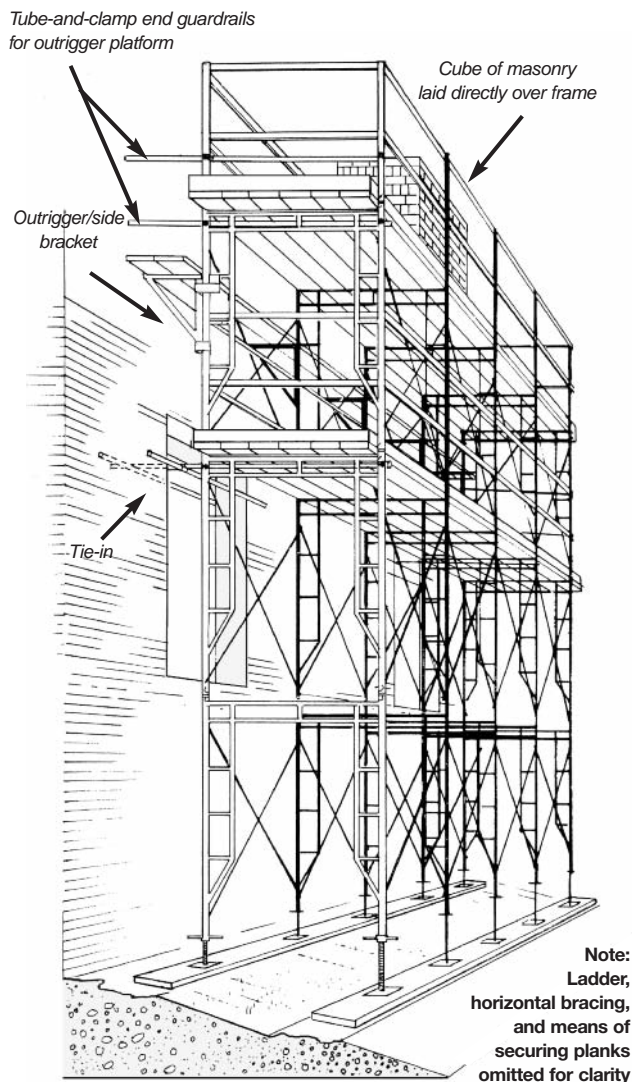


Figure 5.4
MASONRY SCAFFOLD WITH OUTRIGGER/SIDE BRACKETS

Use the following good work practices:

- Do not drop or roughly handle outrigger/side brackets during erection or dismantling. This can bend or damage hooks.
- Use planks that are double-cleated at one end to ensure that the cleats are engaged over a bracket to prevent the bracket from pivoting.
- Inspect brackets as they are being installed on the scaffold to ensure that only sound brackets with no defects are used.

- Tag for repair any brackets that have deformed or cracked hooks, cracked welds, or other defects.
- Make sure that brackets are mounted securely on the frame all the way down.
- Never stock material on the bracket working platform. The working platform is for the worker only.
- Make sure that planks laid on the brackets extend at least 150 mm (6 inches) beyond the frames at either end.
- Place brackets so the level where the worker stands is no more than 1 metre (40 inches) below the level where the material is stored.

Beware of common hazards with outrigger/side brackets:

- hooks bent or deformed to the extent that they will roll off the frame under load
- hooks bent back into place, thereby causing cracks in the metal or welds which then break under load
- homemade brackets that are poorly designed and fabricated, too flimsy to bear the load, or not sized properly to hold two planks
- failure to inspect brackets during erection to ensure that they are not damaged
- failure to use planks that have double cleats on one end.

Other features to look for are

- manufacturer's plate showing name and model number
- brackets that are hot-dipped galvanized
- manufacturer's literature stating that the bracket has been designed and fabricated to meet loading requirements specified in the Ontario regulations and applicable CSA standards.

5.3 Ladders

Whether built into frames, attached as a separate component, or portable, ladders are an important means of access to scaffold platforms. We would substantially reduce the number of falls connected with climbing up and down scaffolds if workers always used adequate and properly erected ladders. Unfortunately, suitable ladders are not often provided or used.

A major problem with ladders built into the frame is that planks sometimes stick out so far that it's difficult to get from the ladder to the platform. This situation results in many injuries but can be overcome in one of three ways:

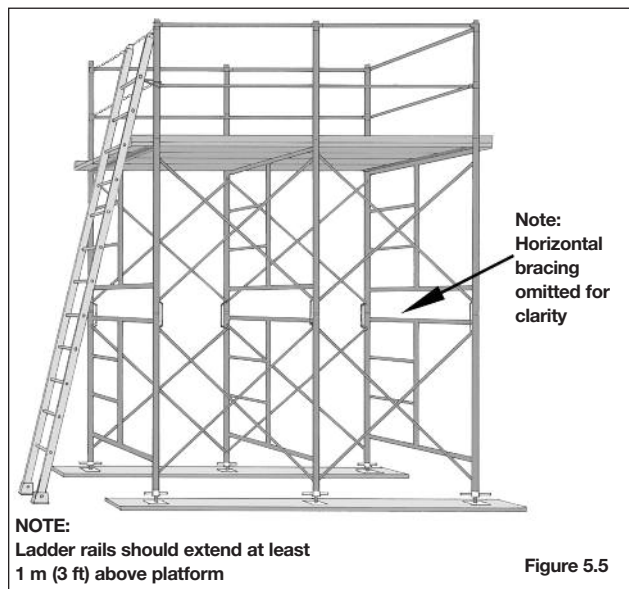
- use manufactured platform components which do not project beyond the support
- use a portable ladder where platform elevations are less than 9 metres (30 feet) in height (Figure 5.5)
- use a stand-off vertical ladder with a cage if the scaffold is above 3 metres (10 feet).

Ladder rails should extend at least 900 mm (3 feet) above the platform level to facilitate getting on and off. Injuries are often connected with stepping on and stepping off the ladder at the platform level.

Rest stations should be decked in on scaffold towers at intervals no greater than every 9 metres (30 feet). Climbing is strenuous work and accidents happen more frequently when climbers suffer from overexertion.

5.4 Guardrails

Failing to use guardrails is one of the main reasons for falls from scaffold platforms. Manufacturers of frame



scaffolds have guardrail components which can be attached to the scaffold frames. These have posts that sit directly onto the connector pins and to which the rails are attached using wing nuts.

Where manufactured guardrails are not available, guardrails can be constructed from lumber (Figure 5.6) or tube-and-clamp components.

Tube-and-clamp guardrails may be constructed from standard aluminum scaffold tubing using parallel clamps to attach the vertical posts to each frame leg (Figure 5.6). Top rails and mid-rails should be attached to the vertical posts using right-angle clamps. Connections in these rails should be made with end-to-end clamps.

Most manufacturers have toeboard clips to fasten toeboards quickly and easily to standard tubular posts on either frames or guardrail posts.

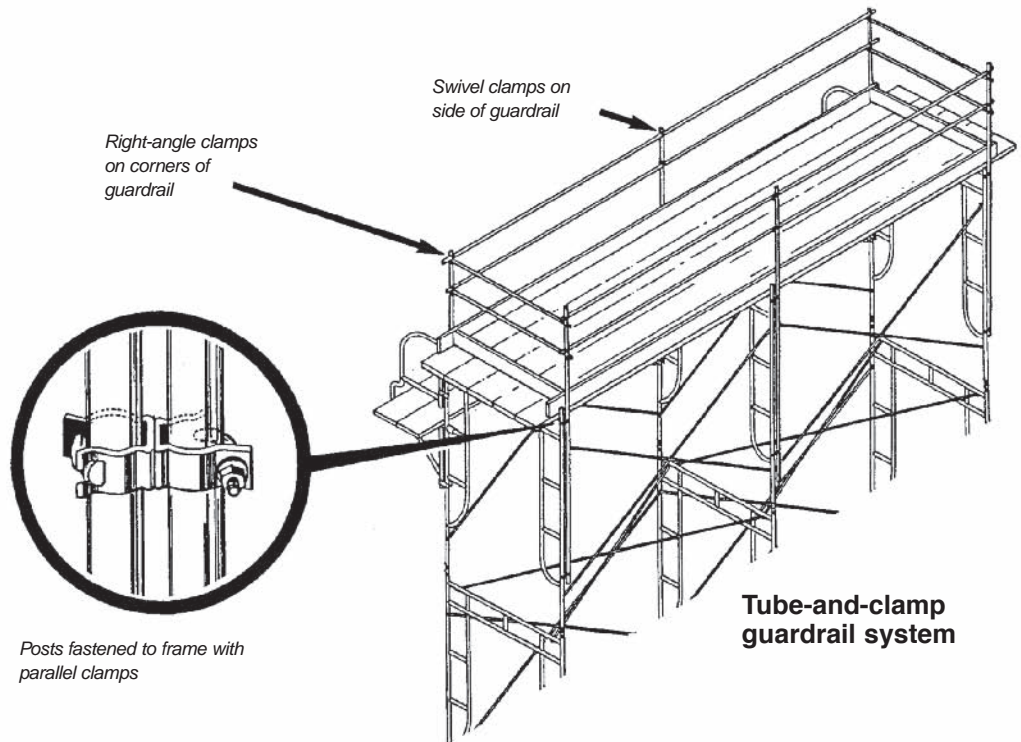
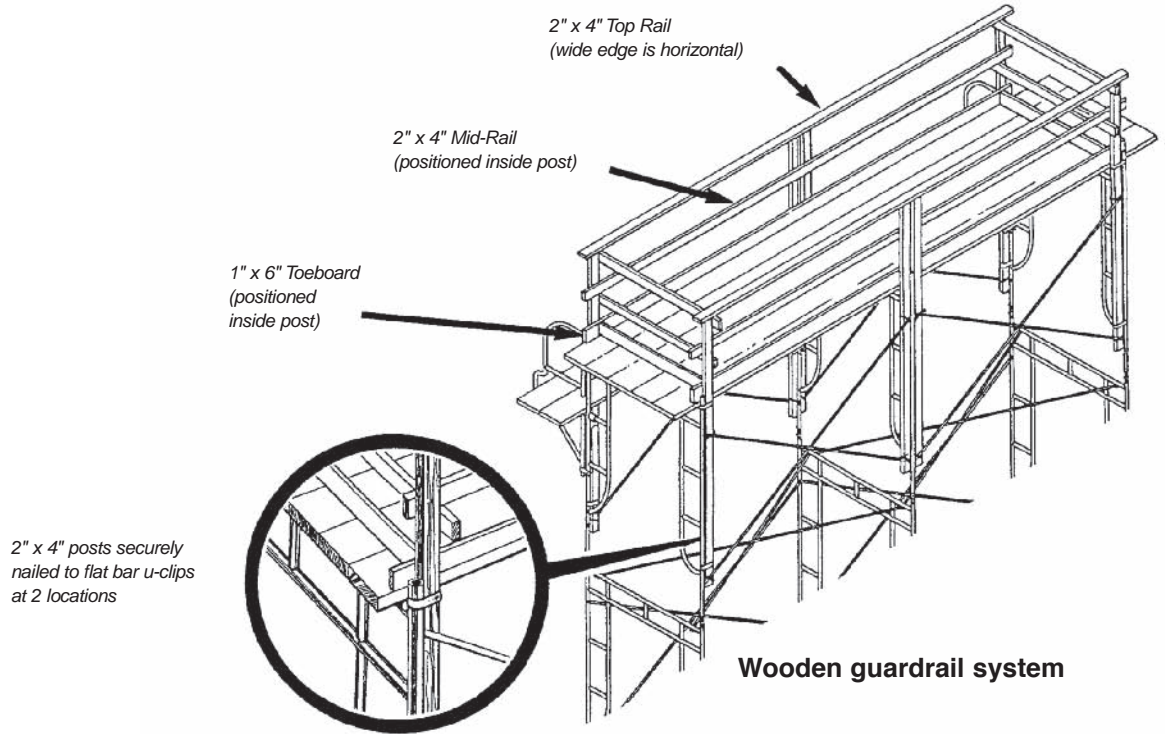
A guardrail should consist of:

- a top rail about 1 metre (40 inches) above the platform
- a mid-rail about halfway between the platform and the top rail
- a toeboard at least 89 mm (3½") high at the platform level if made from wood, and
- posts no more than 2.4 metres (8 feet) apart if made from wood. Guardrail posts can be farther apart if the materials used are adequate to support the loads specified.

Guardrails should be designed to resist the forces specified in the Construction Regulation.

Frequently, guardrails must be removed to allow material to be placed on the scaffold platform. Workers must protect themselves from falling by using a fall-arrest system properly worn, used, and tied off. The fall-arrest system should be worn while the worker is removing the guardrail, receiving the material, and replacing the guardrail. Too often, guardrails are removed to receive materials and then not replaced. Many workers have fallen because other workers have left unguarded openings on scaffold platforms.

Figure 5.6
GUARDRAILS



6 ERECTING AND DISMANTLING SCAFFOLDS

6.1 General

Scaffolds should always be erected under the supervision of a competent worker. Although scaffold systems vary between manufacturers, certain fundamental requirements are common to all scaffold systems. Frame scaffolds over 15 metres (50 feet) in height, and tube-and-clamp and systems scaffolds over 10 metres (33 feet), must be designed by a professional engineer. Supervisors must ensure that the scaffolds are constructed in accordance with that design.

6.1.1 Foundations and Support Surfaces

Scaffolds must be erected on surfaces that can adequately support all loads applied by the scaffold. To support scaffolds, backfilled soils must be well compacted and levelled. Mud and soft soil should be replaced with compacted gravel or crushed stone. Embankments that appear unstable or susceptible to erosion by rain must be contained. Otherwise, the scaffold must be set far enough back to avoid settlement or failure of the embankment.

Where mudsills must be placed on sloping ground, levelling the area should be done, wherever possible, by excavating rather than backfilling (Figure 6.1).

In some cases it may be necessary to use half-frames to accommodate grade changes. For these situations the side bracing is usually provided by using tube-and-clamp components.

Floors are usually adequate to support scaffold loads of workers, tools, and light materials. As loads become greater, floors, especially the older wooden types, should be examined to ensure that they will support the anticipated loads. In some cases, shoring below the floor and directly under the scaffold legs may be necessary. In other situations, you may need sills that span the floor support structure.

Scaffolds erected on any type of soil should have a mudsill. At minimum the mudsill should be a 48 mm x 248 mm (2" x 10") plank (full size) and should be continuous under at least two consecutive supports. The scaffold feet should rest centrally on the mudsill and the sill should, where possible, project at least 300 mm (1 foot) beyond the scaffold foot at the ends. Mudsills may be placed either along the length or across the width of the frames.

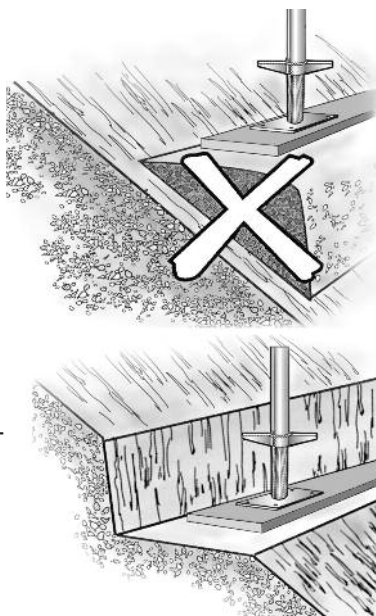
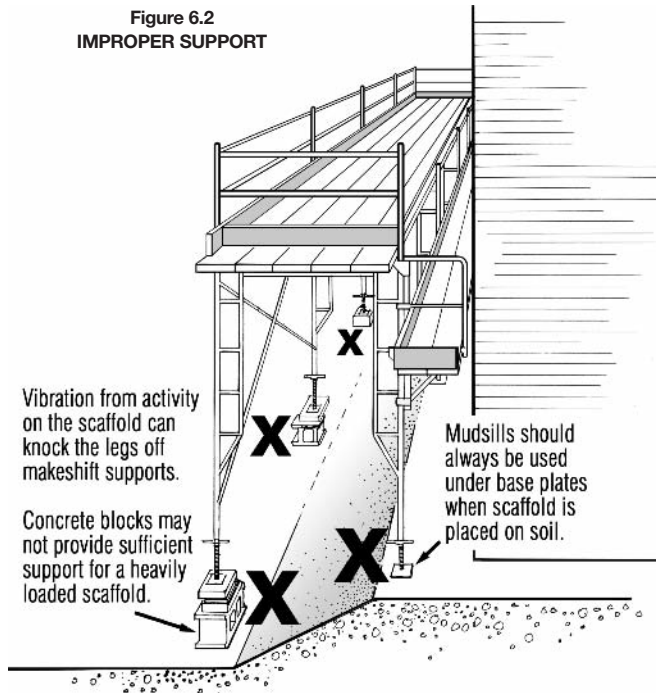


Figure 6.1
MUDSILL ON SLOPING GROUND

Do not use blocking or packing such as bricks, short pieces of lumber, or other scrap materials either under scaffold feet or under mudsills (Figure 6.2). If the scaffold is subjected to heavy loading, bricks or blocks can break. Vibration can cause blocking to move or shift, leaving a scaffold leg unsupported. In such conditions the scaffold can topple when heavy loads are applied.

Figure 6.2
IMPROPER SUPPORT



Take particular care when erecting scaffolds on frozen ground. Thawing soil is often water-soaked, resulting in considerable loss of bearing capacity. You must take thawing into account when tarps or other covers will be placed around a scaffold and the enclosure will be heated.

If the scaffold is inside a building, preparing the foundation may mean

- clearing away debris or construction materials and equipment stored in the way
- using sills or placing shoring under old wooden floors.

For a scaffold on the outside of a building, preparing the foundation may include

- replacing mud and soft ground with gravel or crushed stone
- levelling and compacting loose backfill
- stabilizing or protecting embankments
- providing protection against erosion from rain or thawing
- using mudsills.

Foundation preparation is important with any scaffold. It is especially important when scaffolds will be heavily loaded, as in masonry work. Differential settlement may damage scaffold components even if no serious incident or collapse occurs.

6.1.2 Inspection

Scaffold materials should be inspected before use for

- damage to structural components
- damage to hooks on manufactured platforms
- splits, knots, and dry rot in planks
- delamination in laminated veneer lumber planks
- presence of all necessary components for the job
- compatibility of components.

Structural components which are bent, damaged, or severely rusted should not be used. Similarly, platforms with damaged hooks should not be used until properly repaired. Planks showing damage should be discarded and removed from the site so that they cannot be used for platform material.

6.1.3 Location

Before erecting a scaffold, check the location for

- ground conditions
- overhead wires
- obstructions
- variation in surface elevation
- tie-in locations and methods.

Checking the location thoroughly beforehand will eliminate many of the problems that develop during erection and will allow erection to proceed smoothly, efficiently, and safely.

6.1.4 Base Plates

Base plates and adjustable screw jacks should be used whether the scaffold is outside on rough ground or indoors on a smooth level surface. Base plates should be centred on the width of the sill and nailed securely after the first tier has been erected. Sills may run either across the width or along the length of the scaffold depending on grade conditions and other factors. Generally, bearing capacity will be increased by running sills longitudinally because the sill has more contact with the ground.

6.1.5 Plumb

When the first tier of scaffold has been erected it should be checked for plumb, alignment, and level. Where necessary, adjustments can be made using the screw jacks.

Settlement or slight variations in the fit of the components may require additional adjustments as tiers are added to the scaffold tower. Braces should fit easily if the scaffold tower is level. If braces do not fit easily it is an indication that the scaffold is out of plumb or out of alignment.

6.1.6 Hoisting Materials

Where scaffolds will be more than three frames high, a well wheel or “gin” wheel and a hoist arm or davit will make the hoisting of materials easier during erection (Figure 6.3).

While materials can be pulled up by rope without these devices, the well wheel and hoist arm allow the hoisting to be done by workers on the ground. This is much safer and eliminates the risk of workers falling from the scaffold platform as they pull materials up by rope. Loads lifted by a well wheel should normally be no more than 50 kg (100 lb.) unless special structural provisions are made.

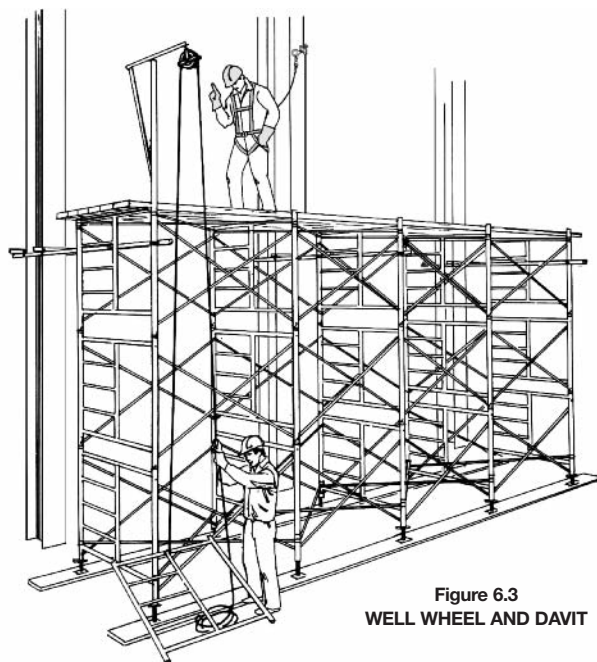


Figure 6.3
WELL WHEEL AND DAVIT

The use of forklifts or other mechanical means of hoisting scaffold materials has become more common particularly in masonry applications. The use of this type of equipment greatly reduces the potential for overexertion injuries due to lifting and pulling. However, extra precaution must be taken to prevent powerline contact and other potential hazards such as overloading.

6.1.7 Tie-ins

Scaffolds must be tied in to a structure or otherwise stabilized—in accordance with manufacturer's instructions and the Construction Regulation—as erection progresses. Leaving such items as tie-ins or positive connections until the scaffold is completely erected will not save time if it results in an accident or injury. Moreover, in most jurisdictions it is prohibited. For further information on tie-in requirements see Section 7.6.

6.1.8 Fall Protection in Scaffold Erection

Providing practical fall protection for workers erecting and dismantling scaffold and shoring has been challenging for the construction industry.

In Ontario, Section 26 of the Construction Regulation requires that workers erecting, using, or dismantling scaffolds must be protected from falling by using guardrails, travel restraint, fall-restricting systems, or fall-arrest systems.

For fall protection while workers are using a scaffold as a work platform, the safest solution is guardrails, provided they can be erected safely. Workers involved in erecting or dismantling scaffolds face a different challenge. Erecting guardrails and using fall-arrest equipment requires specialized procedures since normally there is nothing above the erector on which to anchor the fall protection system. For suggestions, see CSAO's *Scaffolds and Frame Shoring Towers: Fall Protection*, which you can download from www.csao.org.

In all cases ensure that procedures comply with the regulations. You must use engineered design and procedures when required, and competent workers must review the installed scaffold before use. Pay special care and attention to anchorages.

A competent person must give adequate oral and written instructions to all workers using fall protection systems. Like all scaffolds, this equipment must be used under the supervision of a competent person.

6.2 ERECTING FRAME SCAFFOLDS

Frame scaffolds are the most common types of scaffolds used in Ontario. Too often they are erected by people who are inexperienced and do not know or recognize the potential hazards. Erectors must be aware of the potential dangers not only to themselves but also to the end user of the scaffold.

6.2.1 Fittings and Accessories

People are sometimes reluctant to install all the parts, fittings, and accessories required for a properly built frame scaffold. This poor practice continues because parts are frequently lost or otherwise not available at the site. Other times, it is due to haste, lack of training, or carelessness.

Always use base plates with adjustable screw jacks. They allow for minor adjustments to keep the scaffold plumb and level. Base plates usually have holes so you can nail them to mudsills. This is good practice and should be done as soon as the first tier is erected and plumbed with base plates centred on the sills.

You must brace in the vertical plane on both sides of every frame. Bracing in the horizontal plane should be done at the joint of every third tier of frames starting with the first tier. Horizontal bracing should coincide with the point at which the scaffold is tied to the building. Horizontal bracing is needed to maintain scaffold stability and full load-carrying capacity. The use of horizontal bracing on the first tier helps to square up the scaffold before nailing base plates to mudsills.

Every scaffold manufacturer provides coupling devices to connect scaffold frames together vertically. Figure 6.4 illustrates various types. Erectors often ignore these devices, believing that the bearing weight of the scaffold and its load will keep the frame above firmly connected to the frame below. This will probably hold true until the scaffold moves or sways. Then the joint may pull apart, causing a scaffold collapse. Coupling devices should always be used and installed properly on every leg of the scaffold, at every joint, as assembly proceeds.

If wheels or castors are used they should be securely attached to the scaffold and be equipped with brakes. Failure to attach wheels or castors properly to the frame has been the cause of many serious accidents and fatalities involving rolling scaffolds. Wheels or castors must have brakes which are well maintained and easily applied.

Scaffolds should always have guardrails. Unfortunately, people frequently leave them out, especially on scaffolds of low to moderate height. Workers have been seriously injured as a result.

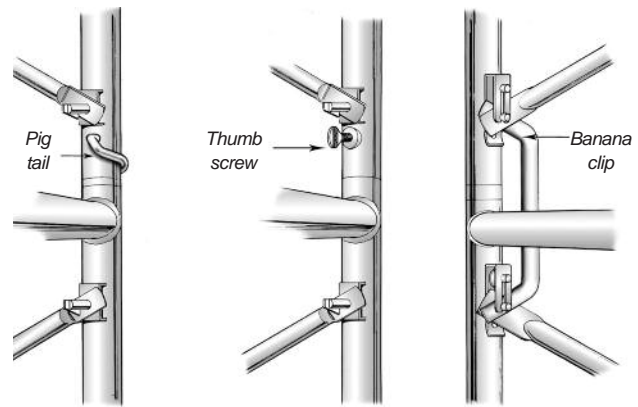


Figure 6.4
COUPLING DEVICES

6.2.2 Braces

Once you have fitted the adjustable base plates on the frames you must then attach the braces for each tower span. The braces should slide into place easily. If force is required, either the braces are bent or damaged or the frames are out of plumb or alignment.

Secure braces at each end. The erection crew must ensure that self-locking devices move freely and have fallen into place. Rust or slight damage can prevent some of these devices from working properly and they then require force to secure them in position. Maintain moving parts in good condition to prevent this situation from developing.

6.2.3 Platform Erection

Ensure that parts and fittings are in place and secure before placing platform components on a scaffold tier.

When proceeding with the next tier, workers should use platform sections or planks from the previous tier, leaving behind either one platform section or two planks. While this requires more material it speeds up erection because workers have platforms to stand on when erecting or dismantling the platform above. At heights above 3 metres (10 feet), all workers involved in the erection or dismantling of scaffolds must be protected by a guardrail or by other means of fall protection.

Frequently, low scaffolds one or two frames in height are not fully decked in. This can lead to accidents and serious injury. Many lost-time injuries occur each year in Ontario because platforms are inadequately decked.

6.2.4 Ladders

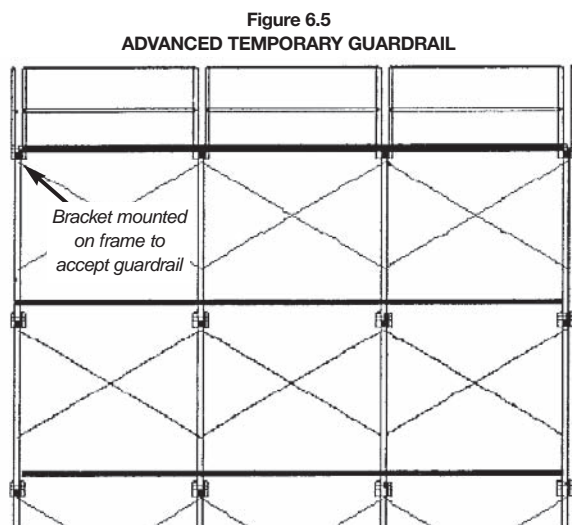
Where frames are not equipped with ladder rungs, ladders should be installed as the erection of each tier proceeds. Injuries involving scaffolds frequently occur when workers are climbing up or down the scaffold. Providing proper ladders will help prevent such injuries. See Section 5.3 for more information on ladders.

6.2.5 Guardrails

Guardrails must be installed at each working level as the scaffold is erected and also at the top level of the scaffold. This is recommended for all scaffolds regardless of height. Although you do not require guardrails until scaffolds are 2.4 metres (8 feet) high, a considerable number of severe injuries and even fatalities are due to falls from lower scaffolds.

Some manufacturers have recently introduced temporary guardrails workers can use when erecting scaffolds. A guardrail can be set in position from the previous level and can provide a protected work platform for the worker to install the next level of components. Each type of guardrail has a unique design and system of attachment to the scaffold.

Figure 6.5 shows one example of an “advanced guardrail” with the platform fully enclosed. The guardrail is positioned on a bracket which is mounted from below on the outside of the scaffold, and does not interfere with the placement of subsequent frames and braces. As the scaffold goes up the guardrail may be raised as well, or left in position to form the permanent guardrail. The erector must use another fall protection method—permanent guardrails or a full body harness with a lanyard attached to the scaffold—while moving either the platforms or the temporary guardrail.



6.3 ERECTING TUBE-and-CLAMP SCAFFOLDS

Most of the general rules that apply to frame scaffolding also apply to tube-and-clamp scaffolding. The requirements for mudsills, platforms, and guardrails are exactly the same for both types.

The most important difference between the two is the additional degree of skill and knowledge necessary to erect tube-and-clamp scaffolds safely and efficiently. Tube-and-clamp scaffolds should not be erected by an unskilled or inexperienced crew. Basic terms are identified in Figure 6.6.

6.3.1 General Requirements

Tube-and-clamp scaffolds are erected plumb and level like frame scaffolds but the erection system is quite different.

The scaffold must start with a set of ledgers and transoms immediately above the base plates. This is necessary to hold the base plates in their proper position. The typical erection sequence for a simple tower is shown in Figure 6.6. Each vertical and horizontal member should be checked with a spirit level as erection proceeds.

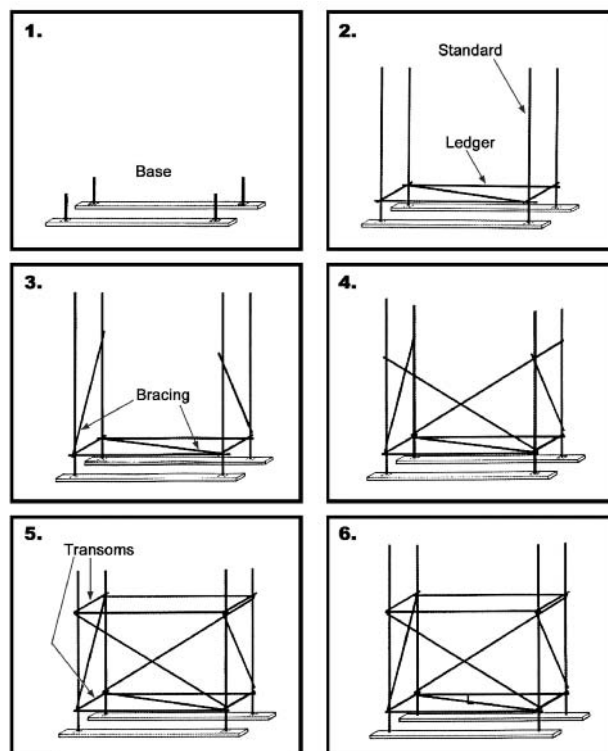


Figure 6.6
ERECTON OF TUBE-AND-CLAMP SCAFFOLD

6.3.2 Materials and Components

The tubing normally used for tube-and-clamp scaffolding in Ontario is schedule 40, 1.9" OD (1½" ID) aluminum pipe manufactured of either 6061 or 6063 alloys.

Clamps are usually made of steel and have a variety of configurations. Depending on the manufacturer, clamps can be fastened using wedges, bolts, or other methods. The following types are used.

- **Right-Angle Clamp**—a clamp used for connecting tubes at right angles. They maintain the right-angled orientation providing rigidity to the structure.
- **End-to-End Clamp**—an externally applied clamp to connect two tubes end-to-end.
- **Swivel Clamp**—a clamp used to connect two tubes when right-angle clamps cannot be used. They usually connect bracing.
- **Parallel Clamp**—a clamp used for lap jointing two tubes together. It can be used to connect short guardrail posts to the standards or legs of frame scaffolds.
- **Concrete Tie Clamp**—a clamp used to connect a tube to concrete or other surfaces using a bolt or concrete anchor.

These and other devices are shown in Figure 6.8 depicting a typical tube-and-clamp scaffold.

Before using clamps, check them carefully for damage to wedges or threads on bolts and distortion of the clamp body.

6.3.3 Spacing of Standards

The spacing of standards depends on the load-carrying requirements of the scaffold. Wherever possible, tube-and-clamp scaffolding should have bay and elevation spacing of about 2 metres (6'-6") longitudinally and vertically. This allows for the front sway bracing to be located at approximately 45° to the horizontal. It also facilitates the use of 5-metre (16-foot) planks with adequate overhang. The width of these platforms can vary but is usually approximately 1 metre (3 feet). This spacing allows the aluminum tubing specified earlier to carry normal construction loads adequately. An advantage of tube-and-clamp scaffolding is that the platform height can be easily adjusted to the most appropriate level for the work being done.

6.3.4 Ledgers and Transoms

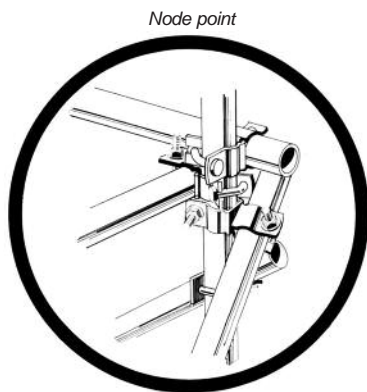
Ledgers should be connected to standards using right-angle clamps. These clamps maintain a rigid 90° angle between members.

Transoms should be placed above the ledgers and both should be maintained in a horizontal position by levelling with a spirit level. Transoms may be connected to either standards or ledgers by using right-angle clamps.

6.3.5 Joints in Standards and Ledgers

Joints in standards and ledgers should be made with end-to-end clamps. These joints should be as close to the node points as the clamp arrangements will allow. Joints in vertically-adjacent ledgers should not occur in the same bay but should be staggered to provide rigidity.

A node point is the point at which the ledger-to-standard, transom-to-standard, and bracing-to-standard connections come together. An example of a node point is shown in Figure 4.7 and below.



6.3.6 Intermediate Transoms

You should install intermediate transoms when the scaffold will be supporting heavy loads. You can also use them to avoid lapping planks and the tripping hazard that comes with it.

6.3.7 Tie-ins

Tie-ins are required with tube-and-clamp scaffolding. They should be located at every second node vertically and

every third standard horizontally. The tie-in tube should be connected to both standards or both ledgers, near the standard to provide rigidity. Connections should be made with right-angle clamps. Tie-ins should be capable of withstanding both tension (pull) and compression (push) forces (Figure 6.8).

6.3.8 Bracing

Internal bracing (Figure 6.8) is connected standard-to-standard using swivel clamps. It should be clamped as close to the node as possible. Internal bracing should normally be placed at every third standard. The location should coincide with tie-in points. You should also install bracing for tube-and-clamp scaffolding as erection progresses.

Face sway bracing should be installed to the full height of the scaffold. It may be located in a single bay or extend across several bays (Figure 6.7). Where the bracing is located in single bays it should be in the end bays and at least in every fourth bay longitudinally. In practice, it becomes difficult to get bracing close enough to the node points if it extends more than four bays in width (see ends of bracing in Figure 6.7).

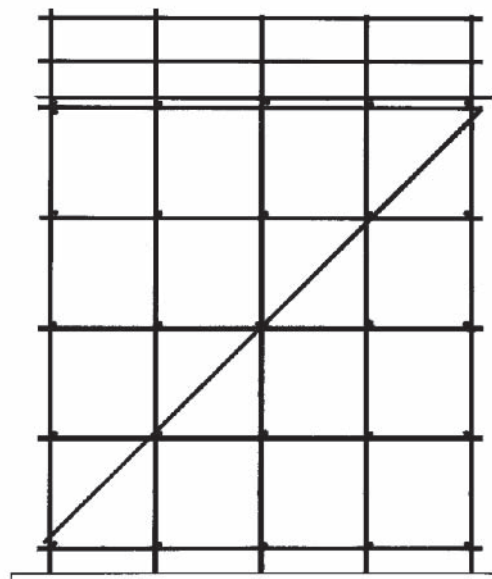
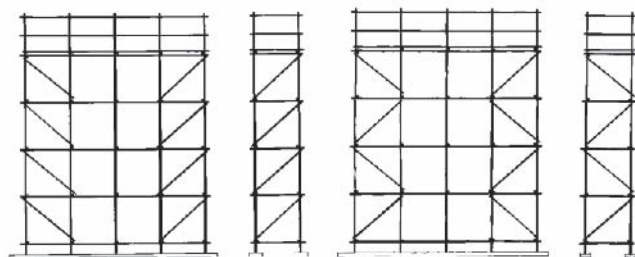
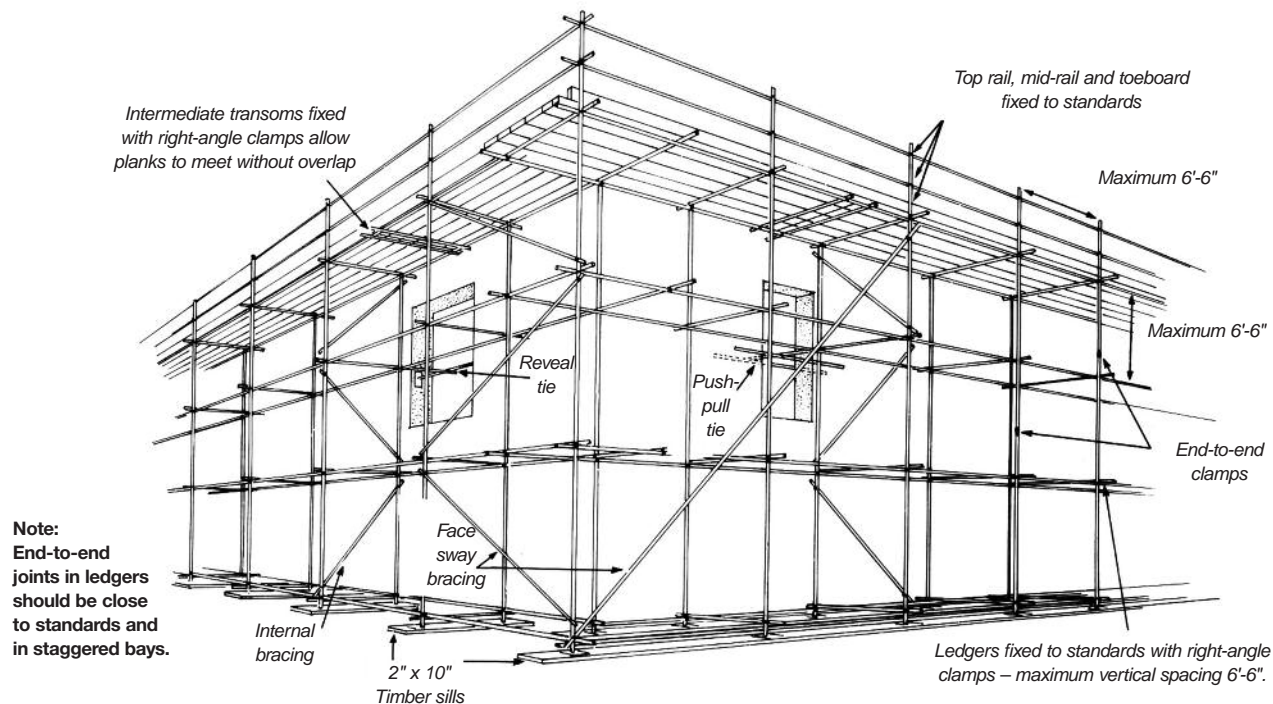
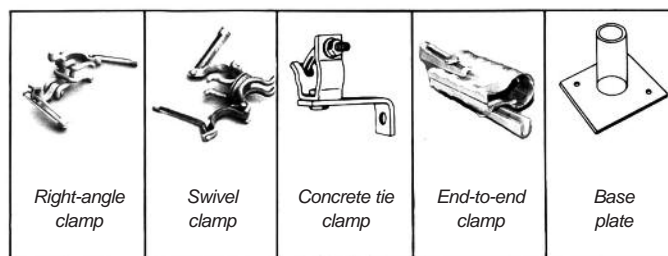


Figure 6.7
TUBE-AND-CLAMP BRACING

6.3.9 Drawings and Inspections

We strongly recommend that a sketch or drawing be prepared before erecting tube-and-clamp scaffolding. It is important that you place the standard to accommodate the anticipated loads adequately. Bracing must also be designed to provide stability and to transfer horizontal loads to tie-in points.

Figure 6.8
COMPLETED TUBE-AND-CLAMP SCAFFOLD



Where the platform will be more than 10 metres (33 feet) high or where unusual structures such as cantilevered platforms are involved, a professional engineer must design the scaffold. A professional engineer or a competent worker must inspect the scaffold before it is used to ensure that it is erected in accordance with the design drawings.

6.4 ERECTION of SYSTEMS SCAFFOLDS

Erection of systems scaffold is very similar to that of tube-and-clamp scaffold. The requirements for mudsills, platforms, and guardrails are the same as is the requirement for being built level and plumb. The main differences are the method of connecting individual members together and the fact that all the members are of a fixed length. As with tube-and-clamp scaffolds, all systems scaffolds above 10 metres (33 feet) must be designed by a professional engineer.

6.4.1 Components

Standards come in a variety of lengths and have a variety of built-in connection points at equal distances along their length. These connectors are normally between 450 and 500 mm (18 and 21 inches) apart depending on the

manufacturer. Typical connections are shown in Figure 6.9, although others are available. An end-to-end connection, normally a spigot, is formed at one end to facilitate extension of the standard.

Starter Collars are short standards with one set of system rings or rosettes attached. They are convenient to use because they allow one person to put the first set of transoms and ledgers in place easily (Figure 6.10).

Ledgers or Runners for each system are available in varying lengths and have built-in connection devices for connecting to the standards. The connection is secured by wedging, bolting, or by other methods.

Transoms or Bearers are made wide enough for four or five planks. They normally have end connections similar to those of ledgers and connect directly to the standard. Normally transoms have a lip or groove—particular to the individual manufacturer—designed to accommodate the platform.

Braces are made in set lengths to fit the scaffold being constructed, with connections at both ends to fit directly onto the connection point on the standard.

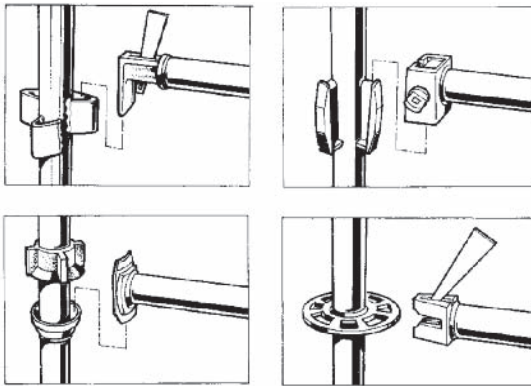


Figure 6.9
TYPICAL SYSTEMS SCAFFOLD CONNECTORS

Platform boards (also called staging) come in a variety of lengths and widths. They fit directly into the transoms and can be secured to prevent wind uplift. To facilitate climbing, some platforms have trap doors with built-in drop-down ladders.

6.4.2 Erection Procedure

The foundation for systems scaffolds should be prepared in the same way as other types of scaffolding, ensuring a firm level base, and using mudsills, base plates, and adjustable screw jacks.

The base plates should be laid out in what you estimate is the correct location. We recommend starter collars since they allow scaffolds to be laid out level and square.

The first level of transoms and ledgers should be placed on the starter collars and be levelled using the screw jacks.

When the scaffold is square and level you should tighten the connections and nail the base plates to the mudsills.

At this point set up an erection platform for installing the standards for the next lift. You now install the second level ledgers and transoms as well as the deck.

You must install ledger bracing at the ends of all system scaffolds and at intervals according to the manufacturers' recommendations. Each brace will be the correct length for the span being braced and should be connected to the attachment point on the standard.

You must install face or sway bracing according to manufacturers' instructions. Again, attachment points are set on the standards, and the braces come in specific lengths for the span of the scaffold being constructed. Normally, every third bay is braced for sway.

Figure 6.10 outlines the typical erection procedure for systems scaffold.

6.4.3 Tie-ins

Systems scaffolds must be tied in to structures using the 3-to-1 rule as with other scaffolds. Some manufacturers have special adjustable ties which connect directly into the standards, while others use a tube-and-clamp method to tie in to the structure. Anchors attached to the structure are the same as in frame or tube-and-clamp scaffolds.

6.4.4 Guardrails

Generally, guardrails are installed at all working levels. These guardrail components come in modular lengths and are made from lighter materials than the ledgers. They attach directly to the connection points on the standards.

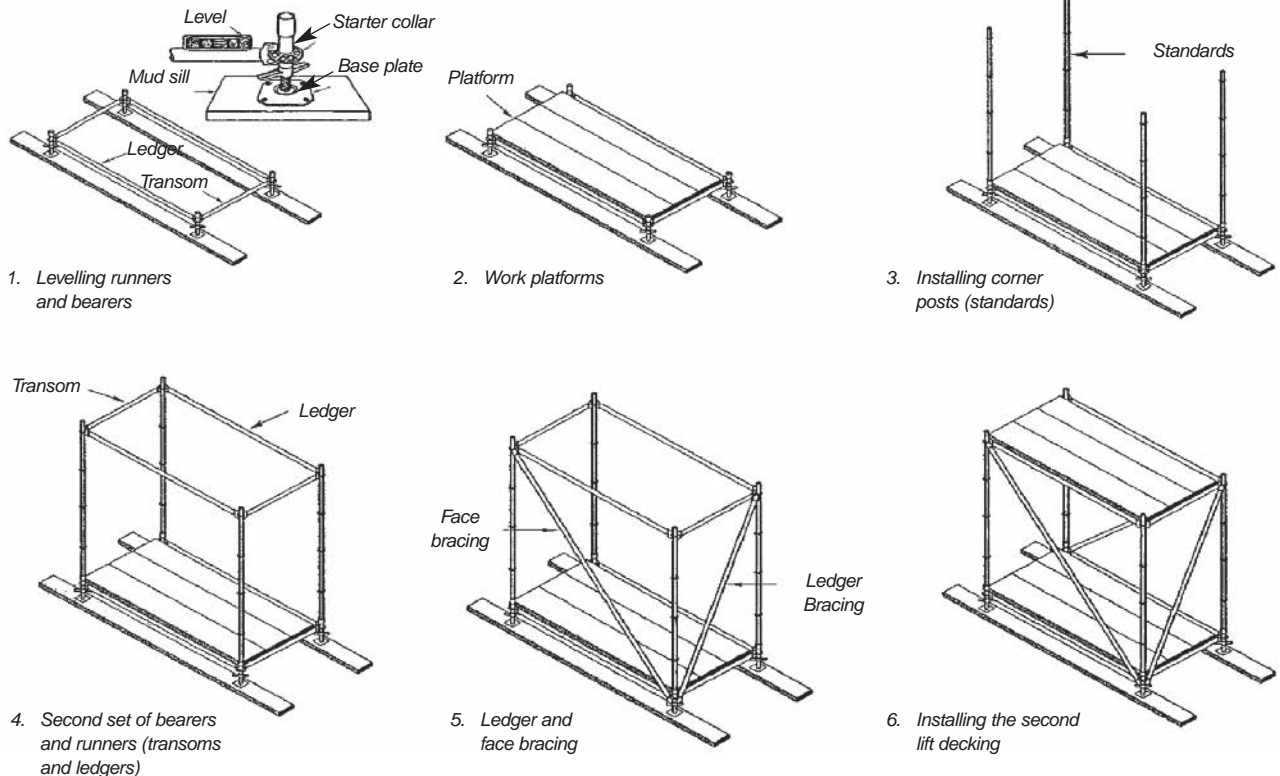


Figure 6.10
ERECTION SEQUENCE OF TYPICAL SYSTEMS SCAFFOLD

Certain manufacturers have developed advanced guardrail systems that can be installed for a level above the erector, providing fall protection for the worker accessing the next level.

The example shown in Figure 6.11 consists of a “T” shaped temporary guardrail which is attached to the permanent guardrails on the level underneath. When mounted, it extends the required distance past the deck above to form a guardrail. The erector can then work safely without being tied off and install the next level of standards, ledgers, and transoms.

6.5 DISMANTLING

Dismantling frame scaffolds is essentially erection in reverse. Each tier should be completely dismantled and the material lowered to the ground before beginning to dismantle the next tier.

If platform sections or planks have been left at each level during erection, as suggested above, it should be relatively easy to lower platform materials from above and deck in the current working platform completely. Extra platform material can be lowered to the ground. Using this procedure, workers will be operating most of the time from a fully decked-in platform. This makes for easier removal of braces and frames.

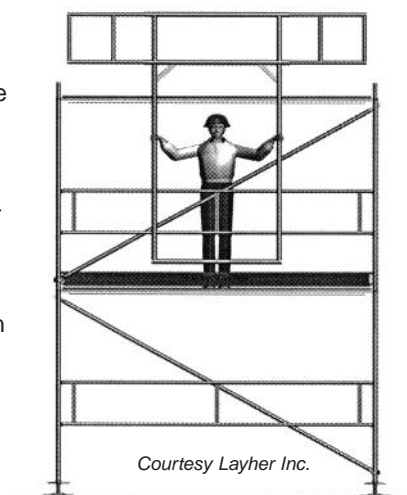
Dismantled materials should be lowered using a well wheel and hoist arm or by mechanical means. Dropping materials not only causes damage and waste, but also endangers workers below—and is illegal in most jurisdictions.

When scaffolds have been in the same location for a long time, pins and other components frequently rust, braces become bent, and materials such as mortar or paint often build up on the scaffold parts. All of these can prevent components from separating easily. Removing jammed or rusted scaffold components can be very hazardous. Tugging or pulling on stuck components can cause you to lose your balance and fall. Workers should wear a full body harness and lanyard tied off to a scaffold frame or lifeline before attempting to loosen stuck or jammed parts.

Dismantling tube-and-clamp and systems scaffolding must proceed in reverse order to erection.

Each tier should be completely dismantled as far as connections will allow before you begin dismantling the lower tier. You must dismantle them this way because the bracing for tube-and-clamp scaffold is not located in each bay as it is for frame scaffolding. The span or spans with front sway bracing should be the last to be dismantled on each tier.

Figure 6.11
ONE STYLE OF
ADVANCED GUARDRAIL SYSTEM



7 SCAFFOLD STABILITY

7.1 Three-to-One Rule

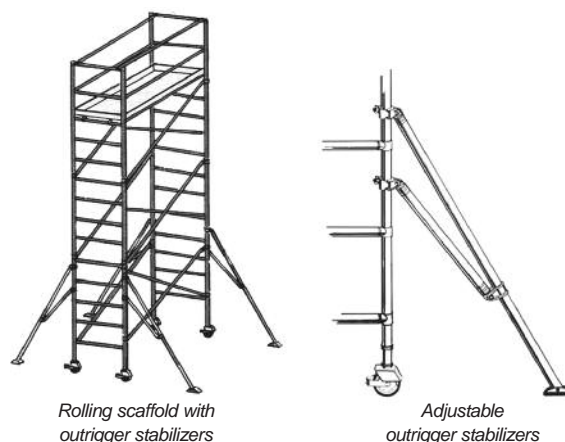
The ratio of height to least lateral dimension must not exceed 3 to 1 unless the scaffold is

- tied to a structure, as discussed in Section 7.6
- equipped with outrigger stabilizers (Figure 7.1) to maintain the ratio of 3 to 1
- equipped with suitable guy wires.

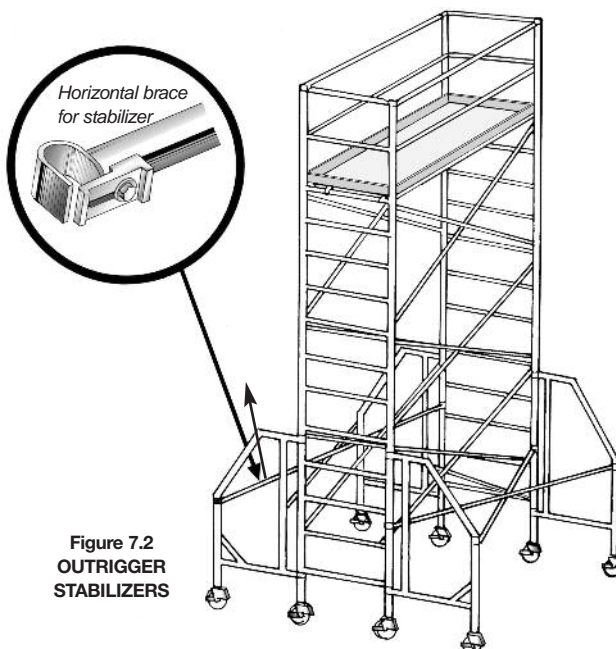
7.2 Outrigger Stabilizers

Scaffold manufacturers usually make outrigger stabilizers that can be attached to their equipment (Figure 7.1).

Figure 7.1
OUTRIGGER STABILIZERS



With devices of this type, ensure that the outrigger is adjusted so that vibration or dynamic loads on the platform will not move the stabilizer. Where stabilizers with castors are used the castors must rest firmly on a solid surface, with the brakes applied, and with the stabilizer secured in the extended position before workers use the platform (Figure 7.2). Many of these stabilizers fold up to allow movement through smaller openings and around obstructions (Figure 7.2).



7.3 Limitations to the Three-to-One Rule

The 3-to-1 rule applies only to the extent that outriggers are extended symmetrically about the scaffold tower. If the outriggers are extended only on one side, you prevent toppling only in that direction.

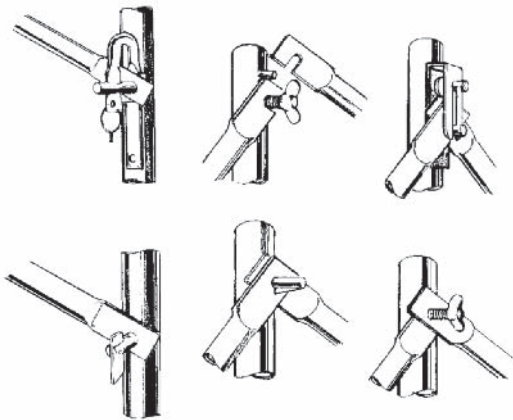
7.4 Damage

Most bracing systems for tubular frame scaffolds are manufactured from light materials and are easily damaged.

Do not use braces with kinks, bends, or deformations.

Such damage can weaken them significantly. The ends of braces are frequently damaged by dropping them on concrete or other hard surfaces during dismantling. Ends of braces are also frequently bent by forcing them onto the locking pin during erection. Constant bending can cause the ends to crack. You should inspect them before use and discard braces with cracked ends. You should maintain the locking device onto which the brace fits in good condition. It should move freely to accept and release the brace. Common securing devices are shown in Figure 7.3.

Figure 7.3
SECURING DEVICES FOR FRAME SCAFFOLD BRACES



7.5 Installation Problems and Symptoms

Ensure that bracing is secured in place. Otherwise, scaffold movement can dislodge the braces and reduce the stability of the scaffold. These devices must secure the braces in place but they must operate freely so that it is easy to erect and dismantle the scaffold. Many times a worker has lost balance and fallen when trying to release a jammed or rusted drop hook while dismantling a scaffold.

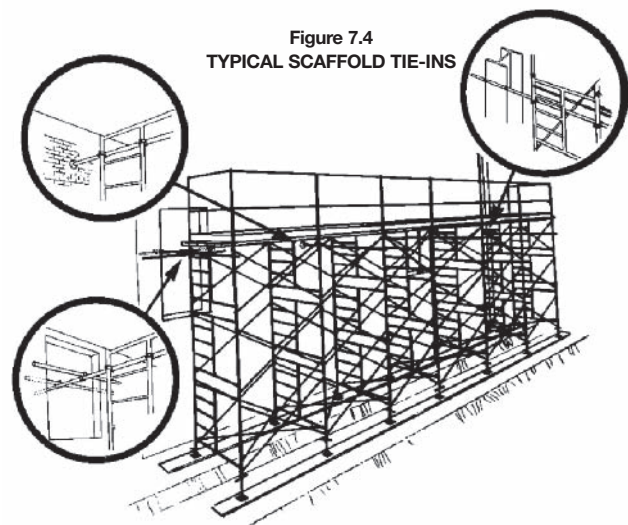
You should completely deck platforms used to install bracing. Trying to work from a platform one or two planks wide often results in a fall. In addition, it leads to greater damage to the ends of scaffold braces because they bend when they are not kept close to proper alignment during installation and removal.

If a brace does not easily drop onto pins something is wrong. The brace may simply be bent and should be discarded. Often, however, it means the scaffold is twisted and out of plumb. Braces should not be forced or hammered onto the pin. The condition causing this difficulty should be corrected so that the brace slides onto the pin easily. Adjusting screw jacks slightly will often solve this problem. However, you need to take care to ensure the scaffold is not adjusted out of plumb.

7.6 Tie-in Requirements

Scaffolds which exceed the 3-to-1 rule of height to least lateral dimension must be tied in to a building or structure. Tie-ins should be applied at every third frame vertically second frame horizontally for tubular frame scaffolds. Tie-ins for tube-and-clamp scaffolds should be applied at every second node vertically and every third standard horizontally.

These tie-ins must be capable of sustaining lateral loads in both tension (pull) and compression (push). Examples are shown in Figure 7.4.



Wind loads can affect tie-ins and bracing. These loads vary not only with speed but also with the exposure of the location and the height and shape of structures where the scaffold is erected. In addition, scaffolds which are going to be enclosed for winter construction or sandblasting will be subjected to significantly greater wind loads. If severe winds are expected it is recommended that a professional engineer be consulted for tie-in requirements.

8 PLATFORMS

Before you select the platform material, you need to assess the weight of the workers, tools, and materials to be supported. You must also take into consideration the spans being used in the scaffold.

8.1 Typical Loads and Requirements

Minimum platform capacities vary from jurisdiction to jurisdiction. In Ontario, the minimum platform capacity is a uniformly distributed load of 2.4 kN/m² (50 lb./sq. ft.) for construction-related work. This is usually sufficient for workers, their tools and equipment, as well as a moderate amount of light materials. It is not sufficient for heavy loads such as those used in masonry construction.

For masonry construction where the scaffold will support large pallets of concrete blocks, minimum capacity should be at least a uniformly distributed load of 7.2 kN/m² (150 lb./sq. ft.). This means that scaffolds with spans of 2.1 metres (7 feet) should be at least double-planked. Aluminum/plywood platforms should also have a layer of scaffold planks on top.

Table 8.1

Maximum loads on planks for scaffold platforms 5 feet in width

5'-0"

7'-0"

Layers of Planks	5'-0"			7'-0"		
	—	≡	≡≡	—	≡	≡≡
UNIFORM LOAD PER SQUARE FOOT	150 lbs.	No. 1			No. 1	
	100 lbs.	No. 1			No. 1	
	75 lbs.	No. 1			No. 1	
	50 lbs.	No. 1			No. 1	
4'X4' PALLET LOADS (POUNDS)	4000	SEL STR	No. 1		SEL STR	No. 1
	2900	No. 1			No. 1	
	2430	No. 1			SEL STR	No. 1
	1760	No. 1			No. 1	
	1520	No. 1			No. 1	

Notes

- Planks are **spruce-pine-fir species group (SPF)**.
- Planks are at least 1⁷/₈" thick and at least 9³/₄" wide.
- Grade is either number one (No. 1) or select structural (SEL STR).
- Allowable stresses conform with CSA Standard CAN3-086-1984 "Engineering Design in Wood."
- No stress increases are included for load sharing or load duration.
- Scaffold platforms are 5' wide and fully decked in.
- Loads indicated are **maximum** for grade and loading conditions. Shaded areas indicate that **no** SPF grades are capable of carrying the loads.

For weights of construction materials and allowable load-carrying capacities of planks at various spans, consult Table 8.1 and Table 9.1.

8.2 Aluminum/Plywood Platform Panels

Most manufacturers make their heavy-duty platforms capable of supporting a uniformly distributed load of 3.6 kn/m² (75 lb./sq. ft.) together with a concentrated load of 227 kg (500 lb.) spread over an area near the centre of the span. The load-carrying capacity of these platforms varies to some extent.

It is recommended that the rated load-carrying capacity be obtained from the supplier and marked on the platform panel if the manufacturer has not provided such information on the equipment already. The light-duty platforms available with much less capacity are not suitable for construction.

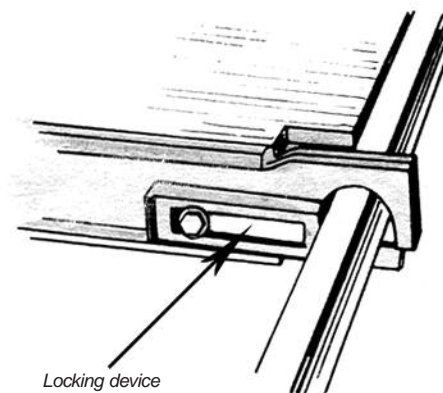


Figure 8.1
SECURING ALUMINUM/PLYWOOD PLATFORMS

The advantage of aluminum/plywood platform panels is that they are light and durable. Worn-out plywood can easily be replaced. However, they are expensive and the hooks on most models can be damaged if dropped from the scaffold repeatedly during dismantling. Check the platform hooks and fastening hardware regularly for looseness, cracking, and distortion. When used outdoors, these platforms should be secured to the scaffold frames using wind locks. Otherwise, when left unloaded, they can be blown off the scaffold by strong winds.

8.3 Laminated Veneer Lumber

This material is really a special type of exterior plywood with laminations oriented longitudinally rather than in two directions. The wood is usually spruce or Douglas fir, although other structural species can be used. The material is manufactured in large sheets of various thicknesses that can be sawn to the sizes required.

The use of laminated veneer lumber as a scaffold platform material is increasing. The strength varies from manufacturer to manufacturer depending on method of fabrication and species of wood used. Users of the material should ask suppliers to furnish rated working loads for the scaffold spans on which the lumber will be used. In general, the material will be stronger than sawn lumber scaffold planks of similar size and species. The strength is also more uniform than sawn lumber.

Like all lumber and plywood, laminated veneer lumber is subject to deterioration from weathering and rot. It must therefore be inspected periodically. Sections showing delamination, cracks, serious damage to several layers of lamination, fungi, or blisters should be discarded.

8.4 Sawn Lumber Planks

Rough sawn planks 48 mm x 248 mm (2 inches by 10 inches) or larger have been the standard scaffold platform material for many years. They are also the least expensive of the common platform materials. **Dressed lumber should never be used for scaffold platforms.**

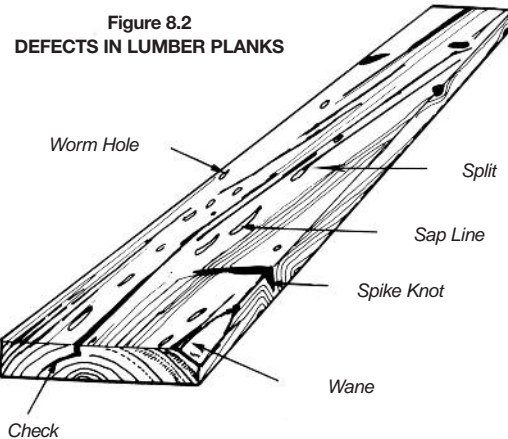
The proper use of planks on a scaffold or other work platform is governed by the Construction Regulation under Ontario's *Occupational Health and Safety Act*. The regulation specifies that wooden planks used on a scaffold must

- be number 1 grade spruce
- bear a legible stamp or be permanently identified as being number 1 grade spruce
- be at least 48 mm by 248 mm ($1\frac{7}{8}$ " x $9\frac{3}{4}$ ")
- be arranged so their span does not exceed 2.1 metres (7 feet)
- overhang their supports by no less than 150 mm (6") and no more than 300 mm (12")
- be laid tightly side by side across the full width of the scaffold at the working level
- be cleated or otherwise secured against slipping
- be capable of carrying any load likely to be applied and as a minimum be capable of carrying 2.4 kilonewtons per square metre (50lb./sq. ft).

It is recommended that planks should meet or exceed the requirements for select structural grades of the species group used, which should be either spruce-pine-fir (SPF) or Douglas fir. Although the SPF group has less strength,

it is usually lighter and therefore easier to handle than Douglas fir. Table 8.1 provides maximum loads based on unit stresses from Canadian Standards Association Standard 086.1-1994 "Engineering Design in Wood" for Number 1 and select structural SPF plank platforms. Sawn lumber planks must be stamped by the manufacturer identifying them as scaffold planks.

Since wood planks deteriorate they must be regraded and culled periodically. For most situations, visual grading is recommended. Scaffold planks must be inspected regularly because they deteriorate with use and age, and are subject to damage. Figure 8.2 illustrates defects to look for when inspecting planks. Cull out planks with large knots in the edge, spike knots, checks, waness, worm holes, and steeply sloping grain patterns. Planks with these defects should not be used as scaffold material and should be destroyed. Scaffold planks can also be weakened by dry rot. It is not easy to notice this condition in its early stages, especially if the exterior of the planks is weathered. Planks substantially infected with dry rot are usually lighter than sound planks of similar size and species. For this reason do not use planks which feel lighter than normal.



8.5 Reinforcing Wood Planks

Wood planks may be reinforced with metal nailer strips or plates. Research conducted by the Construction Safety Association of Ontario has indicated that the strength of weaker planks may be increased considerably by this technique but it should only be used to increase the strength of planks that are of the proper grade. Do not use this as a method of upgrading inferior grades for scaffold use.

The advantages of strengthening planks by this method are twofold:

- planks are not as likely to be cut up or used for purposes other than scaffold planks
- you have additional assurance that poorer quality planks undetected in the grading process will not break prematurely causing an accident.

WARNING: Nailer plates should not be placed over the portion of the plank resting on the scaffold support—unless cleats are used to prevent the plank from sliding—since there is little friction between the bearing surfaces.

Take care when handling planks reinforced in this way since sharp edges can cut your hands.

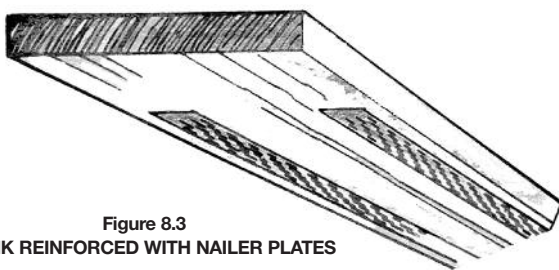


Figure 8.3
PLANK REINFORCED WITH NAILER PLATES

8.6 Securing Platforms to the Frame

Be sure to secure platforms against sliding or movement. Workers frequently fall from platforms because they did not first secure the platform materials. Aluminum/plywood combination platforms have hooks that prevent longitudinal movement but will slide sideways on the scaffold unless the platform is fully decked in.

Sawn lumber planks should be cleated on at least one end to prevent longitudinal movement (Figure 8.4). You can also prevent movement by wiring a plank (Figure 8.6). Unless you carefully apply it, the wire can present a tripping hazard on the platform. Again, the platform should be fully decked in to prevent sideways movement.

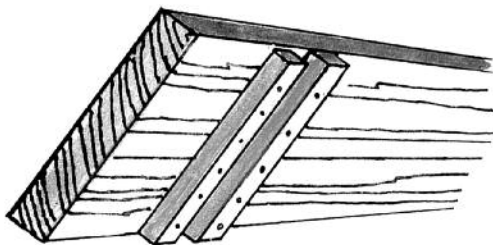
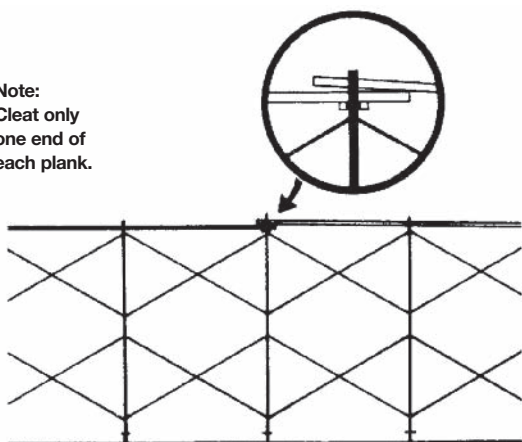


Figure 8.4
PLANK CLEATED TO PREVENT SLIDING

If you have overlapping planks, the cleated end should be resting on the scaffold support. Be aware that the overlapped section presents a tripping hazard (Figure 8.5).

Figure 8.5
OVERLAPPING PLANKS FOR MULTI-SPAN TOWERS

Note:
Cleat only
one end of
each plank.

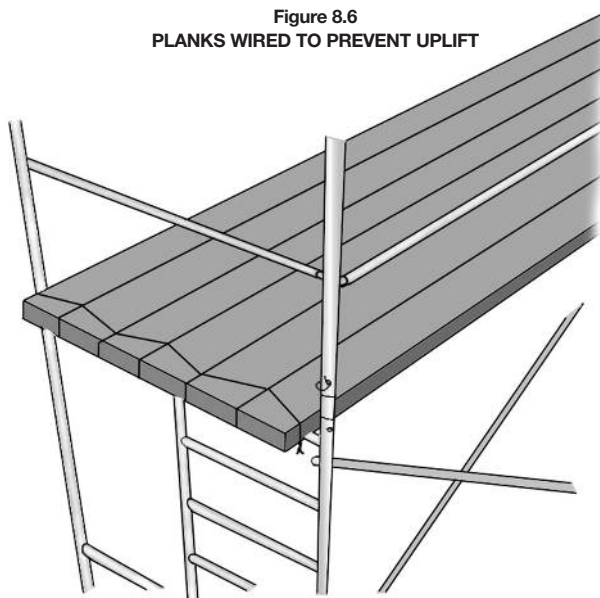


8.7 Wind Uplift

Wind can lift light platform materials from the scaffold if they are not secured. When you anticipate severe wind conditions or when you are using high scaffolds, you should secure platform materials such as aluminum/plywood panels to the scaffold. With some types of platform panels you can do this with wire or nails.

Others have a sliding locking device (Figure 8.1). These locking devices, however, can be easily damaged and are often difficult to apply and release.

Figure 8.6
PLANKS WIRED TO PREVENT UPLIFT



9 PROPER USE OF SCAFFOLDS

Much of this chapter deals with the erection and dismantling of various types of scaffolds. Frequently, the end user of the scaffold is not the person who erects it. In order for scaffolds to provide efficient access to work areas they must be used properly by all workers.

9.1 Ladders and Climbing

We discussed ladder access in Section 5.3. The ladder must be properly erected with rails projecting 1 metre (3 feet) above the platform of the scaffold. You should clear debris, extension cords, and tools away from areas around the top and bottom of ladders. Store materials away from these locations.

Falls often happen when workers are getting on or off the ladder at the platform level. Both hands must be free to hold guardrails or ladder rails. Do not carry tools or materials by hand when climbing ladders. Wear a tool belt and pouch and move material up or down by rope.

You should always place portable straight ladders with an adequate slope and secure them to the scaffold structure (Figure 5.5).

Always use three-point contact (Figure 9.1) when climbing ladders. This means using two hands and one foot, or two feet and one hand, to maintain contact with the ladder at all times. Always face the ladder when climbing and always keep your centre of gravity between the two ladder rails.

For more information, refer to the Ladders chapter of this manual.

9.2 Guardrails Missing or Removed

There may be situations where scaffolds must be used without guardrails. If the scaffold is more than one frame or tier in height and there are no guardrails, personnel on the platform must tie off with a full body harness and

Figure 9.1
THREE-POINT CONTACT



Note: Vertical ladders above 3 metres in height must have a safety cage beginning 2.2 metres above the ground or platform. The cage is omitted here for clarity.

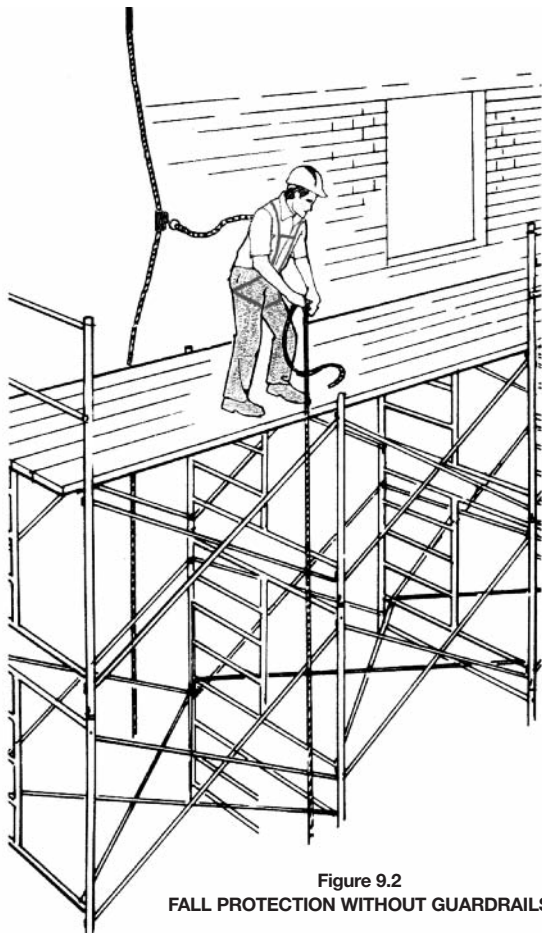


Figure 9.2
FALL PROTECTION WITHOUT GUARDRAILS

lanyard (Figure 9.2). Many falls and serious injuries occur when workers use platforms without guardrails. Any worker who removes a guardrail for any reason must replace it when the task is completed.

9.3 Standing on Objects Above the Platform

People working from the platform should have both feet on the platform. Standing on a barrel, box, stepladder, guardrail, or other object to gain extra height is extremely dangerous and is illegal in most jurisdictions, including Ontario. You should know the required height of the scaffold before erecting it, so you can obtain all the required material, including half frames when necessary.

9.4 Overloading

Overloading scaffold platforms in the masonry trades is one of the most frequent violations of good scaffold practice. Placing full pallets of bricks or concrete blocks on a single layer of 48 mm x 254 mm (2" x 10") scaffold planks is, in most cases, overloading the platform. You may have to double plank decks to support pallets of masonry materials. Place the pallets over the supports wherever possible. In addition, inspect planks used to support masonry materials for damage or for deterioration regularly and often. Table 8.1 indicates the load-carrying capacities of various grades of plank. Table 9.1 lists the approximate weights of common building materials. Bear in mind overloading may affect stability as well as load-carrying capacity.

Differential settlement is often a problem when you apply heavy loads to scaffolds resting on uncompacted soils. A scaffold tower 9 metres (30 feet) high that settles 25 millimetres (1 inch) on one side can move 150 millimetres (6 inches) at the top. Settlement puts stress on braces, tie-ins, and frame joints. Place heavy loads symmetrically on the platform to ensure that soil settlement is uniform.

Finally, the scaffold structure must be capable of carrying the load that you will apply. Both light-duty and heavy-duty frames are available on the market. Do not use light-duty frames where you have heavy loads. If you do not know the load-carrying capacity of the frames, consult the manufacturer or supplier. The load-carrying capacity of frames usually varies with the height of the towers.

9.5 Debris on Scaffold Decks

Scaffold decks are small, narrow, and confined. Store tools and materials in an orderly fashion. Do not allow debris and waste materials to collect on the platform. Put them in a container or remove them from the platform immediately. Set up a plan for dealing with waste materials. Simply throwing garbage off the scaffold is extremely dangerous—don't do it. If work on the scaffold is likely to result in debris falling, such as in masonry work, then cordon off the scaffold to prevent workers from entering the area.

Waste pieces of lumber, pipe, wire, miscellaneous metal, and small tools are tripping hazards which have caused

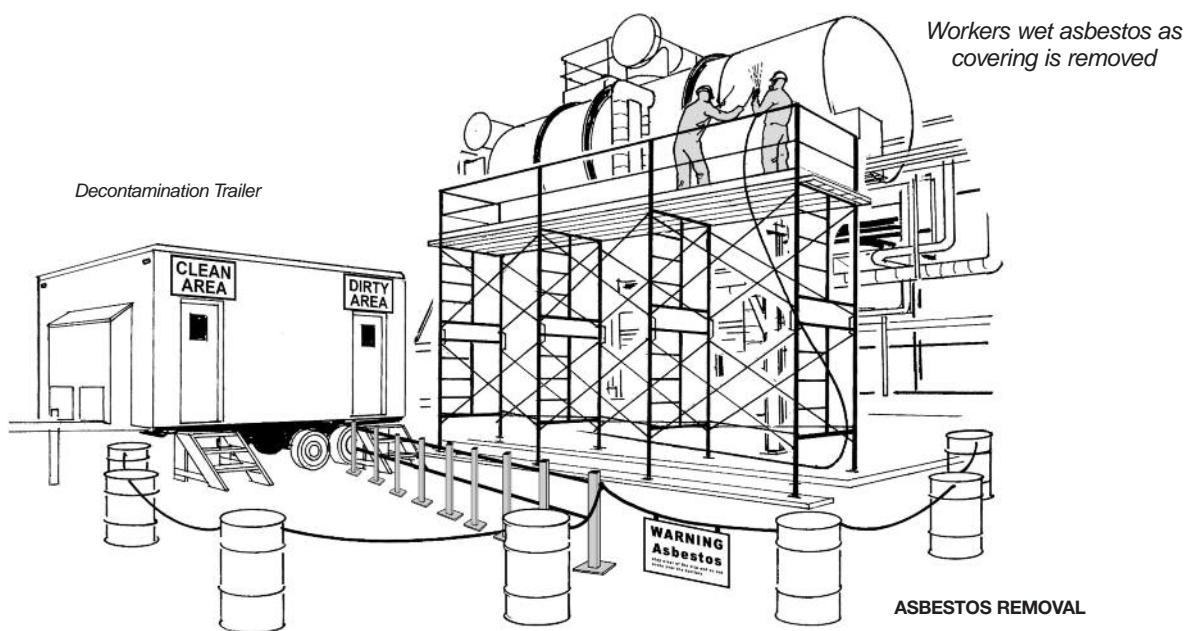


Table 9.1

APPROXIMATE WEIGHTS OF BUILDING MATERIALS

Material	Metric Unit Weight	Imperial Unit Weight
Aluminum	2643 kg/cu m	165 lb/cu ft
Iron (Wrought)	7769 kg/cu m	485 lb/cu ft
Steel	7849 kg/cu m	490 lb/cu ft
Nickel	8730 kg/cu m	545 lb/cu ft
Glass (plate)	2563 kg/cu m	160 lb/cu ft
Lumber (dry)		
Cedar (white)	352 kg/cu m	22 lb/cu ft
Douglas Fir	513 kg/cu m	32 lb/cu ft
Maple	689 kg/cu m	43 lb/cu ft
Red Oak	657 kg/cu m	41 lb/cu ft
Spruce	433 kg/cu m	27 lb/cu ft
Concrete	2403 kg/cu m	150 lb/cu ft
Granite	2803 kg/cu m	175 lb/cu ft
Brick	1922 – 2243 kg/cu m	120 – 140 lb/cu ft
Limestone, Marble	2643 kg/cu m	165 lb/cu ft
Sandstone	2082 kg/cu m	130 lb/cu ft
Steel Pipe (standard)		
1" I.D.	2.49 kg/m	1.68 lb/ft
2" I.D.	5.43 kg/m	3.65 lb/ft
3" I.D.	11.27 kg/m	7.58 lb/ft
4" I.D.	16.05 kg/m	10.79 lb/ft
Copper Pipe		
1" I.D.	2.71 kg/m	1.82 lb/ft
2" I.D.	6.28 kg/m	4.22 lb/ft
3" I.D.	13.02 kg/m	8.75 lb/ft
4" I.D.	19.20 kg/m	12.90 lb/ft
Aluminum Pipe (standard)		
1" I.D.	0.86 kg/m	0.58 lb/ft
1-1/2" I.D.	2.40 kg/m	1.61 lb/ft
2" I.D.	3.08 kg/m	2.07 lb/ft
3" I.D.	4.57 kg/m	3.07 lb/ft
Drywall (1/2" thick)	10.25 kg/m ²	2.10 lb/ft ²

many serious falls from scaffolds. You need an orderly work area to work safely on scaffolds.

9.6 Exposure to Hazardous Material

Frequently scaffolds are erected for work involving hazardous substances: e.g., refurbishing structures painted with lead-based paint. If you are sandblasting painted surfaces, lead can accumulate on planks and other components. Workers carrying out these activities must use appropriate personal protective equipment. The scaffold worker who has to dismantle the scaffold can also be at risk from the lead residue. Under these conditions you should do the following.

1. Clean components that are likely to be contaminated by lead dust, preferably by washing with a hose before dismantling begins.
2. Cap scaffolding frames and standards as the scaffold is being erected to prevent lead dust from accumulating inside and being subsequently released during the dismantling process.
3. If it is not possible to wash down the scaffolding before dismantling, then scaffold workers should wear properly fitting N100 filtering facepiece respirators while dismantling. The scaffold should then be washed before it is removed from the site.
4. Proper attention to personal hygiene is critical when dealing with lead. Workers must be instructed not to eat, drink, or smoke without washing their hands. A sign or notice indicating this should be conspicuous.
5. Workers should be provided with separate "clean" and "dirty" areas. Use the dirty area for changing out of contaminated clothing and the clean area for changing into uncontaminated clothing and eating. Washing facilities with clean water, soap, and individual towels should separate the two areas.
6. Scaffold workers should inform their physician if they are exposed to lead. The physician may want to monitor the level of lead in the person's blood to see if it is within normal parameters.

22 ELEVATING WORK PLATFORMS

Basic Types

There are two basic types of elevating work platforms—boom and scissor. Both types come in

- *on-slab models* for use on smooth hard surfaces such as concrete or pavement
- *rough-terrain models* for use on firm level surfaces such as graded and compacted soil or gravel.

Both types share three major components: base, lifting mechanism, and platform assembly.

Scissor-Type Machines

These are raised and lowered by hydraulic pistons and an expanding scissor mechanism. Platforms are available in various configurations with different capabilities for extension and movement. Some have extendable platforms or platforms that can rotate. Extendable platforms should be retracted before raising or lowering the device. Typical machines are illustrated in Figure 1.1.

On-slab units

- not designed for uneven or sloping ground
- normally have solid rubber tires
- generally powered by rechargeable DC battery
- some powered by internal combustion engine, either gasoline or propane
- most have “pothole protection”—a metal plate lowered close to the ground to afford some protection against inadvertent movement into depressions or debris.

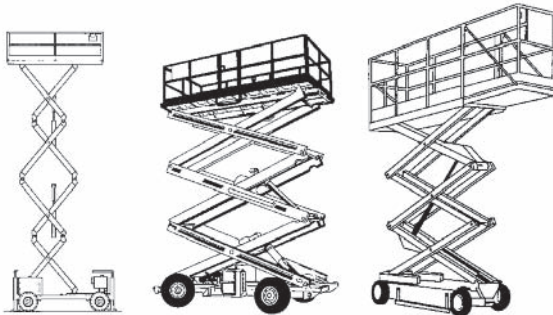


Figure 1.1: Scissor-type powered platforms

Rough-terrain units

- similar in design to on-slab machines
- built to handle rigorous off-slab challenges
- normally have wider wheel bases, larger wheels, and pneumatic tires
- some fitted with outriggers for extra stability
- usually powered by internal combustion engines, gasoline, diesel, or propane
- DC units also available but not common
- lifting mechanism is hydraulic.

Scissor-type machines range in capacity from 500 to several thousand pounds. They are available with platform heights often reaching 15 metres (50 feet) and beyond.

Scissor-type machines must be set up on stable level ground, even with outriggers deployed. A slight imbalance or instability is amplified when the machine is raised.

Figure 1.2 shows one example of controls. Although fixed to the platform, the controls are moveable from one side of the platform to the other. This enables the operator to see the path of travel.

The controls must be oriented correctly so that the operator does not inadvertently move the machine in the wrong direction. Many machines have colour-coded directional arrows on the chassis to aid the operator in moving the machine.

Controls

1. Emergency stop button
2. Choke
3. Stop/start switch
4. Run/idle switch
5. Lift up/down switch
6. Drive high range/low range switch
7. Forward/reverse joystick
8. Left/right steer switch
9. Traversing deck out/in switch
10. Outriggers up/down switch

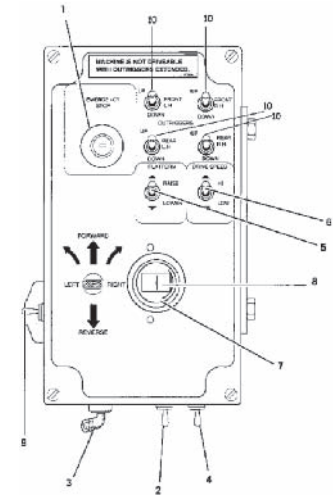


Figure 1.2: Example of controls on scissor-type platforms

Self-Propelled Boom-Supported Platforms

- normally fitted with rough-terrain undercarriages
- some smaller on-slab units
- platforms have lifting capacity of about 227 kg (500 pounds) or two workers
- lack capacity of scissor-type machines; not intended for lifting materials
- usually powered by an internal combustion engine, gasoline, diesel, or propane.

Booms

- telescopic, articulating, or combination of both
- raised and extended by hydraulic cylinders
- can reach up to 45 metres (150 feet)
- can extend well beyond the wheelbase.

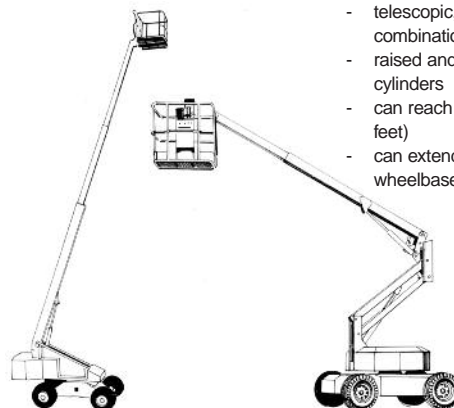


Figure 1.3: Boom-type powered platforms

Figure 1.4 shows one example of controls for a boom machine. Although controls are fixed in position, the operator may become disoriented by machine rotation and must remain aware of the direction of movement. Many machines have colour-coded directional arrows to help the operator move the machine in the right direction.

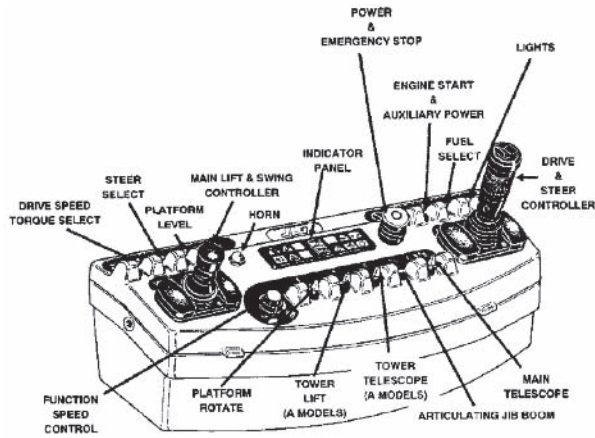


Figure 1.4: Example of boom-machine controls

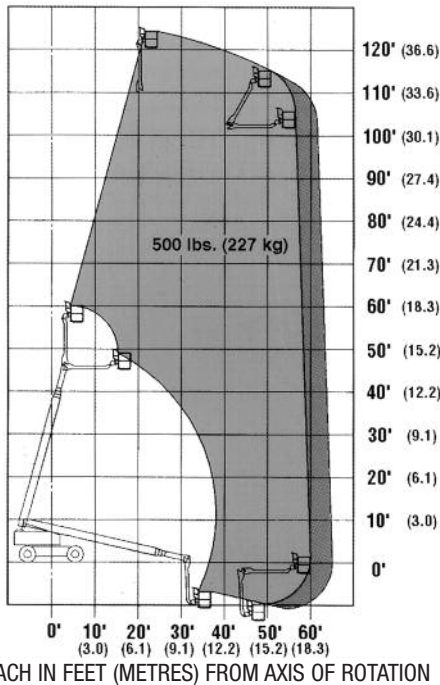


Figure 1.5: Reach chart for a 120-foot (36-metre) machine

As with mobile cranes, stability decreases with length of boom and boom angle as the centre of gravity moves in relation to the platform position. The machine will overturn if the centre of gravity moves outside the machine's base.

Machines come with load charts that show safe operating configurations. Machines with booms long enough to cause overturning at low boom angles are required to have radius-limiting interlocks to prevent operation in unstable configurations.

The reach chart shown in Figure 1.5 indicates the safe operating configurations for a machine with 36 metres (120 feet) of reach operating on a level surface.

The reach diagram in Figure 1.6 shows the safe operating envelope for a 10-metre boom machine.

Notice that the machine does not achieve its maximum height directly overhead. Nor does it achieve its maximum reach at ground level.

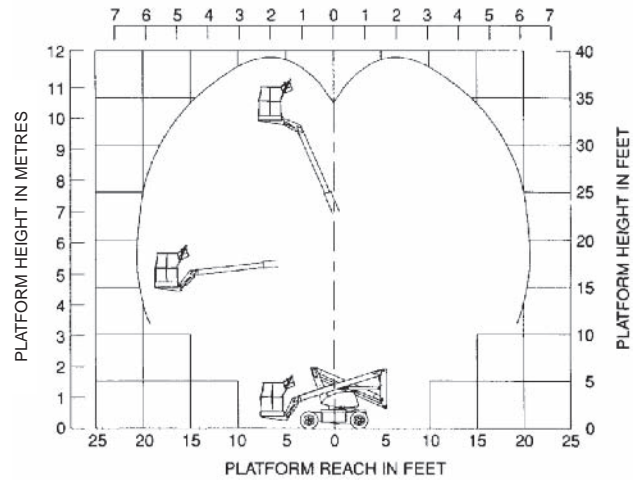


Figure 1.6: Reach diagram for a 10-metre articulating boom platform

Users must be familiar with the operating range of the individual make and model they are using. This knowledge is essential in order to position the machine correctly and reach the work location safely.

Non-Self-Propelled or Push-Arounds

As the name indicates, these units are not self-propelled and must be transported from one location to another with an independent power source or manually in the case of the smaller devices.

The machines are intended primarily for use on smooth, level, hard surfaces or on-slab conditions. Some trailer-mounted units are available.

Many of these devices can fold up to pass through a standard door and can be transported by pick-up truck. As a result they are suitable for maintenance or renovation work.

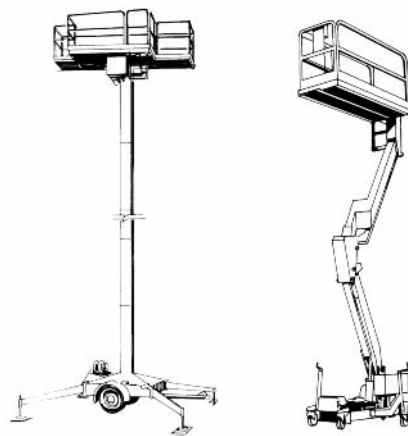


Figure 1.7: Push-around powered platforms

Push-Arounds

- Raising mechanism normally powered by gasoline or propane engine or by electric motors, either AC or DC
- normally raised and lowered by hydraulic cylinders
- platform capacities vary from 300 to 1000 pounds or more but are generally less than 500 pounds
- devices with capacity less than 500 pounds are **not recommended** for construction—better suited to maintenance activities

- platforms don't usually exceed 11 metres (36 feet) in height
- as platform is raised, risk of overturning increases
- extra care required when operating at maximum height.

Selection

Elevating work platforms are designed for different uses. It is essential to select the right machine for the job.

Typical Mistakes

- using an on-slab machine on rough terrain
- using a unit undersized with respect to height, reach, and lifting capacity
- lifting large materials that overhang the platform
- using a scissor lift where the reach of a boom-type machine is needed
- extending the platform with planks, ladders, or other devices because the machine can't reach the required height.

Factors to Consider

Capacity – Does the machine have the lifting capacity, the reach, and the height to complete the task?

Surface conditions – Are the surface conditions hard or soft, sloped or level? Will the ground have an effect on the type of machine selected?

Platform size and configuration – Do you need a regular or extendable platform? Is rotation required? Are there space restrictions to consider?

Mobility – Is a boom type better suited than a scissor lift to the task at hand?

Material to be lifted – Will the machine be able to lift the size and weight of material required for the job?

Access – Will the machine be able to travel around the workplace safely? Are there obstructions or depressions that will restrict the use of certain machines?

Operator skill or training – Are the people on site competent to operate the machine? If a propane-powered engine is used, has the operator received propane training?

Work environment – If the work is to be done indoors or in a poorly ventilated area, will an electrically powered machine be required?

Basic Hazards

The following are some basic hazards.

Machine tipping or overturning

Many factors cause instability—sudden stops, depressions, drop-offs, overreaching, overloading, etc. Overturning and tipping result in many fatalities and injuries.

Overriding safety features

Disarming features such as the tilt or level warning and the deadman switch can prevent operators from knowing when they are in a dangerous situation. Overriding the deadman switch has resulted in a fatality; so has malfunction of the tilt warning.

Overhead powerline contact

Contacting overhead wires can cause electrocution. This can happen with any type of machine—and with the loads carried by or overhanging the machine.

Makeshift extensions

When the machine can't reach the working height desired, don't compensate by using scaffold planks, ladders, blocks of wood, or other makeshift arrangements. Such practices lead to falls and machine instability.

Overloading the platform

EWPs overloaded or loaded unevenly can become unstable and fail. Boom-type machines are especially sensitive to overloading. Always stay within the operating range specified by the manufacturer.

Failure to cordon off

- EWPs have been struck by other construction equipment or oncoming traffic when the work area is not properly marked or cordoned off.
- Workers have been injured when they inadvertently entered an unmarked area and were struck by falling material, tools, or debris.
- In unmarked areas, workers have also been injured by swinging booms and pinched by scissor mechanisms.

Accidental contact

Many EWPs have blind spots. Moving the machine or platform may cause contact with workers or with obstacles. Use a designated signaller on the ground to guide the operator when the path of travel isn't clear or access is tight.

Improper maintenance or modifications

EWPs should be maintained by competent workers in accordance with manufacturer's instructions. No modifications should be made to the machine without the manufacturer's approval.

Improper blocking during maintenance

Failing to block, or improperly blocking the machine, boom, or platform can cause serious crushing injuries and property damage.

Improper access

Don't enter or leave the platform by climbing the scissors or the boom. Don't use extension ladders to gain access. Ladders exert lateral loads on the platform that can cause overturning. For the safest access, lower the machine completely.

Moving with platform raised

Lower the platform before moving the machine unless 1) the machine is designed to move with platform raised and 2) the supporting surface is smooth and level. Slight dips and drops are amplified when the platform is raised and can cause the machine to overturn.

Improper refuelling

Take care when refuelling. Gasoline, for instance, should be kept in approved containers and dispensed to prevent spills and sparking.

Pinch points

Clothing, fingers, and hands can get caught in scissor mechanisms. As platforms are raised, machines may sway. Workers can be pinched between guardrails and the structure. Position the platform so that work takes place above guardrail height.

Regulations and Responsibilities

The construction regulation (Ontario Regulation 213/91) includes the following requirements:

- Elevating work platforms must be engineered and tested to meet the relevant standard for that equipment [section 144(1)(a)]. Standards include
 - CSA B354.1: non-self-propelled elevating work platforms
 - CSA B354.2: self-propelled elevating work platforms
 - CSA B354.4: boom-type elevating work platforms.
- The devices must be checked each day before use by a trained worker [section 144(3)(b)].
- The owner or supplier must keep a log of all inspections, tests, repairs, modifications, and maintenance [section 145(2)].
- The log must be kept up to date and include names and signatures of persons who performed inspections and other work [section 145(3)].
- A maintenance and inspection tag must be attached near the operator's station and include the date of the last maintenance and inspection and the name and signature of the person who performed the work [section 146].
- Workers must be given oral and written instruction before using the platform for the first time. Instruction must include items to be checked daily before use [section 147].
- All workers on the platform must wear a full body harness or a safety belt attached to the platform while the platform is being moved [section 148(e)].

The health and safety responsibilities of all parties on a construction site are outlined in the “green book”—the *Occupational Health and Safety Act and Regulations for Construction Projects*.

Because elevating work platforms are often rented from an equipment supplier, there is confusion as to the responsibilities of the parties involved. Generally, the responsibilities can be summarized in the following way.

The owner or supplier must ensure that the machine

- is in good condition
- complies with regulations
- is maintained in good condition
- conforms to the appropriate CSA Standard
- includes the correct load rating charts if required.

The employer and supervisor on the project must

- ensure that the operator is competent
- ensure that the machine has the correct load rating capacity for the job
- maintain the equipment and all its protective devices
- maintain a log book for each platform
- ensure that workers use appropriate personal protective equipment
- keep the manufacturer's operating manual on site
- train workers on each class of equipment being used.

The worker or operator of the equipment must

- receive adequate training to be fully competent
- only operate the machine when competent
- operate the machine in a safe manner and as prescribed by the manufacturer and the company's

- health and safety policy
- inspect the equipment daily before use
- perform function tests before use
- report any defects to the supervisor
- read, understand, and obey the manufacturer's safety rules, including the operating manual and warning decals.

When a defect is reported to the supervisor, the equipment must be taken out of service until the repairs are completed and the equipment is inspected and approved for use.

Stability and Tipping

In general, EWP's are well manufactured and are safe to use within their specific limitations. As with any equipment or tool, there are do's and don'ts to follow.

One of the most dangerous hazards in operating EWP's is tipping over. This can be caused by one or several of the following factors:

- sudden movement of the unit or parts of the unit when elevated
- sudden stopping when elevated
- overloading or uneven loading of the platform
- travelling or operating on a slope or uneven terrain
- changing the weight distribution of the machine by replacing parts with others of a different weight or adding attachments not approved by the manufacturer
- holes or drop-offs in the floor surface causing one wheel to drop suddenly
- operating the equipment in windy conditions (refer to the operator's manual for safe operating conditions).

It is important that users understand what makes a platform stable and what causes it to overturn. To understand stability, one must understand the concept of centre of gravity, tipping axis (or tipping point), and forces that shift the centre of gravity.

Stability is resistance against tipping over. Stability depends on the location of the centre of gravity in relation to the tipping axis.

Centre of Gravity

Every object has a centre of gravity. It is the point where the object's weight would be evenly distributed or balanced. If a support is placed under that point, the object would be perfectly balanced.

The centre of gravity is usually located where the mass is mostly concentrated. However, the location doesn't always remain the same. Any action that changes the

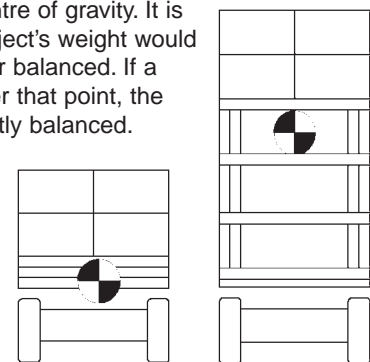


Figure 4.1 Centre of gravity on scissor lifts

machine's configuration—such as raising the platform, extending the boom, or travelling on a slope—can change the location of the centre of gravity.

Figure 4.1 shows how raising a scissor-type platform affects the centre of gravity.

Tipping Axis and Area of Stability

When an EWP turns over, it tips around an axis or point. This is called the tipping axis or tipping point. EWPs typically have four tipping axes – front, back, left, and right.

Each EWP has its own area of stability. This varies from platform to platform and from model to model. In most cases, the area of stability is bound by the four tipping axes (or the four tires or outriggers). The platform is stable as long as the centre of gravity remains inside the area of stability. This is the key to safe operation.

Figure 4.2 shows how lowering the boom angle affects the centre of gravity. In this example the centre of gravity moves towards the platform but remains inside the area of stability.

When the centre of gravity shifts beyond the area of stability, the machine will tip over. Some factors that can cause a shift beyond the stability area are overloading, moving on excessively sloped ground, a sudden drop of one wheel, and shock loading.

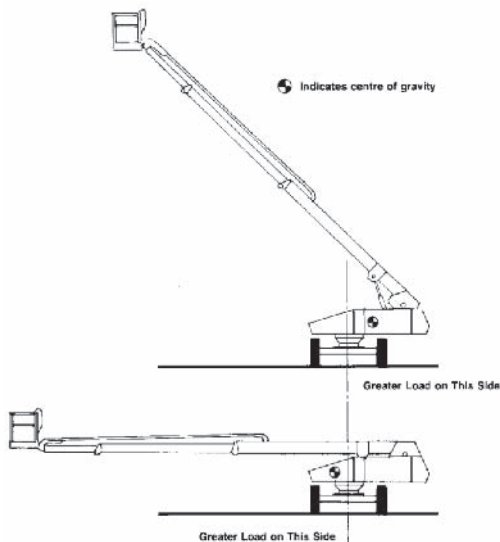


Figure 4.2: Centre of gravity for a boom-supported machine

Raising the platform also raises the EWP's centre of gravity. When a scissor lift is situated on a slope, and the platform is raised, the platform's centre of gravity will move toward the tipping axis. If the centre of gravity moves beyond the tipping axis, the platform will overturn.

Boom-supported EWPs work in the same way. When the boom is extended outward, the centre of gravity moves outwards towards the tipping axis. The EWP will overturn if the boom is extended such that the centre of gravity moves beyond the axis. Boom-type machines have an interlocking system that prevents the machine from moving into an unstable configuration.

Factors Affecting Stability

Dynamic Forces

Dynamic forces are forces generated by movement or change of movement. For example, applying the brakes suddenly or travelling too fast around corners can cause instability – as in a car or van. Sudden stops while raising or lowering the platform can also cause instability.

Travelling

Travelling the platform over rough or uneven ground can also cause instability.

Figure 4.3 shows how a tire dropping 100 mm can cause the boom to sway 600 mm. It is important to lower the platform fully or to retract telescoping sections while travelling, particularly on uneven surfaces.

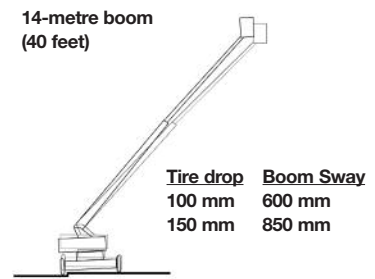


Figure 4.3: Effect of uneven ground on boom sway

Equipment Inspection

All components which bear directly on the safe operation of the EWP and can change from day to day must be inspected daily. Inspection is mostly visual – done in a quick but thorough manner.

Users must check the operator's manual for a complete list of pre-operational checks.

Minimum Requirements

Before climbing into the platform, check

- ✓ Tires for proper pressure and wheels for loose or missing lug nuts
- ✓ Steer cylinder, linkage, and tie rods for loose or missing parts, damage, and leaks
- ✓ Hydraulic hoses, lift cylinder(s), and connections for leaks or loose connections (for example, a small pool of hydraulic fluid)
- ✓ Fuel supply – adequate fuel, filler cap in place, no damage, leaks, or spills
- ✓ Hydraulic oil for leaks and fluid level, battery for fluid level and state of charge
- ✓ Proper connection of all quick-disconnect hoses
- ✓ Structural components for damage, broken parts, cracks in welds, including scissor arms, outrigger arms, and pads
- ✓ Ladder or steps for damage and debris (ladder must be firmly secured to the platform and relatively free of grease, mud and dirt)
- ✓ Beacon and warning lights for missing and defective lenses or caps
- ✓ Ground controls (manual and powered)—including emergency stop switch and platform lower/lift switch—for proper function and damaged and missing control sticks/switches
- ✓ Decals and warning signs to make sure they're clean, legible, and conspicuous.

On the platform, check

- ✓ Platform assembly for loose and missing parts, missing or loose lock pins and bolts
- ✓ Platform floor for structural damage, holes, or cracked welds and any dirt, grease, or oil that can create a hazard
- ✓ Operator's manual to make sure it's in place
- ✓ Extendable platform deck for ease of extension/retraction and proper function of locking position of platform
- ✓ Guardrails to make sure they're in place
- ✓ Access gate for ease of movement, missing parts, latch, and locking capabilities
- ✓ All fall protection anchorage points
- ✓ All control mechanisms for broken or missing parts
- ✓ All emergency controls for proper function—stopping, descending, master OFF switch
- ✓ All safety devices such as tilt and motion alarms for malfunction
- ✓ Swivels for freedom of rotation
- ✓ Scissors for smooth movement up and down
- ✓ Brakes for stopping capabilities
- ✓ Horn for proper function.

Manuals, Signs, and Decals

Section 144(8) of the construction regulation (Ontario Regulation 213/91) specifies the signs that are required on an EWP.

Signs clearly visible to the operator at the controls must indicate

- the rated working load
- all limiting operating conditions, including the use of outriggers, stabilizers, and extendable axles
- the specific firm level surface conditions required for use in the elevated position
- such warnings as may be specified by the manufacturer
- other than for a boom-type elevating work platform, the direction of machine movement for each operating control
- the name and number of the National Standards of Canada standard to which the platform was designed and
- the name and address of the owner.

In addition to the above, the CSA standards for EWPs require the following signs:

- the make, model, serial number, and manufacturer's name and address
- the maximum platform height
- the maximum travel height, if not equal to the maximum platform height

- the nominal voltage rating of the batteries, if battery-powered
- a warning to study the operating manual before using the equipment
- a notice outlining the required inspections
- diagrams or description of the various configurations in which the platform can be used
- the capacity in each configuration
- a statement as to whether or not the platform is insulated
- warnings against replacing, without the manufacturer's consent, components critical to the machine's stability—for example, batteries or ballasted tires with lighter weight components (the minimum weights of such components must be specified).

Many of these signs are vital to the operation of the machine and the protection of workers. All signs and decals must be kept clear of dust and grease so they can be easily read. Torn or damaged signs must be replaced. A typical warning sign is shown in Figure 5.1.

CSA standards also require that the manufacturer provide a manual containing the following information:

- description, specifications, and capacities of the platform
- the operating pressure of the hydraulic or pneumatic system that is part of the work platform
- instructions regarding operation and maintenance, including recommended daily, weekly, and monthly inspection checklists
- information on replacement parts.

The manual must be stored on the platform in a weather-proof storage container.

Safe Practices

Specific Requirements

For the specific EWP they will use, operators must be familiar with

- the manufacturer's operating manual
- the manufacturer's warning and caution signs on the machine
- the location of all emergency controls and emergency procedures
- the daily maintenance checks to perform.

General Guidelines

- Always check for overhead powerlines before moving the machine or operating the platform. You must observe the minimum permitted distances from overhead powerlines (see table, next column). When equipment operates within reach of (and could therefore encroach on) the minimum distance from a powerline, make arrangements with the owner of the utility to have the powerline de-energized. Otherwise,



Figure 5.1

the constructor is required to have written procedures in place to prevent equipment from encroaching on the minimum distance. Copies of the procedures must be available for every employer on the project. See section 188 of the Construction Regulation for further requirements.

- Allow for movement or sway of the lines as well as the platform. Be aware of overhanging tools or equipment.

Voltage Rating of Powerline	Minimum Distance
750 to 150,000 volts	3 metres (10 feet)
150,001 to 250,000 volts	4.5 metres (15 feet)
over 250,000 volts	6 metres (20 feet)

- Wear a full body harness and tie off to a designated tie-off point while the machine is moving.
- Do not leave the machine unattended without locking it or otherwise preventing unauthorized use.
- Don't load the platform above its rated working load (RWL). Wherever possible, keep the load below 2/3 of the RWL.
- Make sure that all controls are clearly labeled with action and direction.
- Keep guardrails in good condition and ensure that the gate is securely closed before moving the platform.
- Shut off power and insert the required blocking before maintenance or servicing.
- Deploy stabilizers or outriggers according to the manufacturer's instructions.
- Don't remove guardrails while the platform is raised.
- Position the boom in the direction of travel where possible.
- Keep ground personnel away from the machine and out from under the platform.
- Don't access the platform by walking on the boom.
- Don't try to push or move the machine by telescoping the boom.
- Do not use the machine as a ground for welding.
- Don't use a boom-supported platform as a crane.
- Don't operate the equipment in windy conditions. For safe wind speeds refer to the operator's manual for the specific make and model you are using.
- Do not place the boom or platform against any structure to steady either the platform or the structure.
- Secure loads and tools on the platform so that machine movement won't dislodge them.
- Make sure that extension cords are long enough for the full platform height and won't get pinched or severed by the scissor mechanism.
- Use three-point contact and proper climbing techniques when mounting or dismounting from the machine (Figure 6.1).

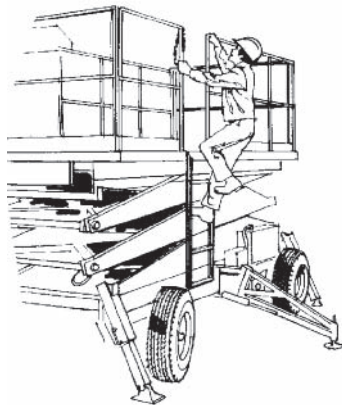


Figure 6.1: Three-point contact

Never operate equipment on which you have not been trained or which you are not comfortable operating. The safety of you and others on site depends on the competent, knowledgeable operation of equipment.

Work Area Inspection

Before operating the EWP, check the work area for

- ✓ drop-offs or holes in the ground
- ✓ slopes
- ✓ bumps or floor obstructions
- ✓ debris
- ✓ overhead obstructions
- ✓ overhead wires, powerlines, or other electrical conductors
- ✓ hazardous atmospheres
- ✓ adequate operating surface—ground or floor
- ✓ sufficient ground or floor support to withstand all forces imposed by the platform in every operating configuration
- ✓ wind and weather conditions.

23 SUSPENDED ACCESS EQUIPMENT

CONTENTS

1. Introduction
2. Equipment types, limitations, and applications
3. Components and rigging
4. Set-up and operation
5. Fall protection
6. Checklists

1 INTRODUCTION

Suspended access equipment of various kinds has been used in construction and restoration for many years. With the increase in high-rise construction there has been a corresponding increase in the number and diversity of applications for this equipment. Unfortunately, there has also been an increase in the number of injuries and fatalities.

In an average year, two fatalities and over 100 lost-time injuries are connected with suspended access equipment in Ontario construction and window cleaning.

This chapter covers the main types of suspended access equipment used in construction, restoration, and maintenance work. It explains the fundamental requirements for set-up, rigging, and use; the necessary provisions for fall arrest; and the importance of assessing each job carefully in order to select the equipment most suitable for safe, efficient operation.

2 EQUIPMENT TYPES, LIMITATIONS, AND APPLICATIONS

Equipment discussed in this section is restricted to factory-built stages, work cages, and bosun's chairs such as the types shown in Figure 1.

Unusual or non-conventional arrangements of equipment should be reviewed by a professional engineer to ensure compliance with applicable standards, regulations, and good practice. In some cases, the services of a professional engineer are required under the Construction Regulation (Ontario Reg. 213/91).

2.1 Special Requirements

Tiered stages and setups where the suspended platform and associated suspended equipment weigh more than 525 kilograms (1,157 lb.) must be designed by a professional engineer.

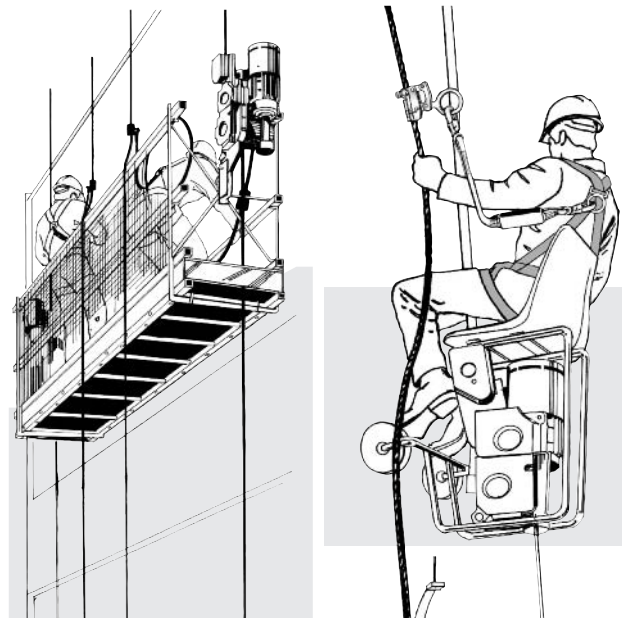
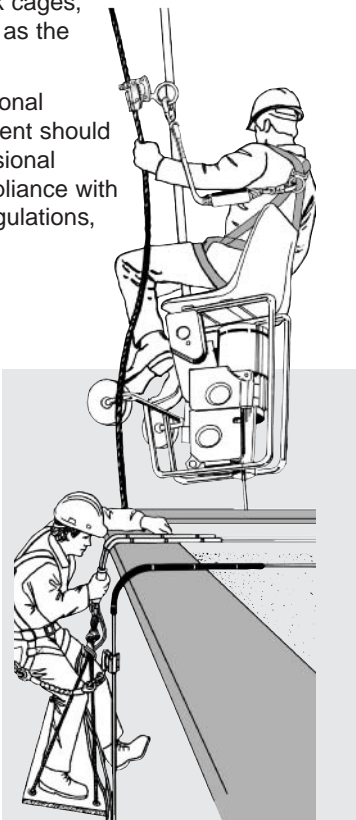
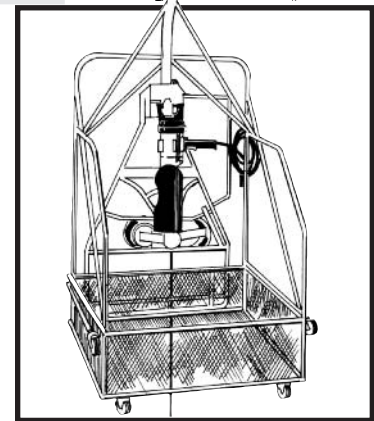


Figure 1
Types of Equipment
Described in this Section



A copy of the design drawings must be kept on the project. In addition, a professional engineer must inspect the suspended scaffold before use and confirm in writing that it has been erected in accordance with the drawings.

2.2 Manual Traction Climber Equipped Stage (Figure 2)

For many years this was the predominant type of suspended access equipment in the industry. More recently it has been replaced by various types of powered climbers, especially where considerable movement is required or heights are greater than 100 feet.

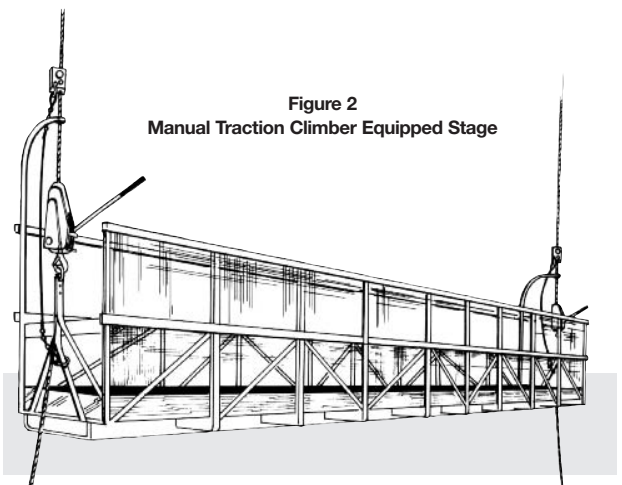


Figure 2
Manual Traction Climber Equipped Stage

This type of equipment is, however, quite suitable for moderate heights where the stage will remain in approximately the same position for a reasonable period of time and where only limited climbing is required.

2.3 Drill-Powered Traction Climber Equipped Stage (Figure 3)

The climbers on these devices are powered by specially designed electric drills. One advantage is that they operate on a 120-volt power supply. This eliminates the requirement for special 220-volt wiring commonly required on larger powered climbers. A disadvantage is that the rate of climb is somewhat slower than for other types of powered climbers.

Drills powering the climbers can be easily removed and stored when not in use, eliminating some of the weather damage and vandalism that occur when other climbing devices are left outdoors.

2.4 Powered Traction Climber Equipped Stage (Figure 4)

This is the most common type of powered climber in use today. Its fast rate of climb makes it ideal where vertical distances are large or frequent movement is required. Usually powered by a 220-volt power source, the unit may require installation of a temporary electrical supply depending on location.

Because of the relatively fast rate of ascent and descent (up to 35 ft/min), operators must take care that the stage does not catch on obstructions such as architectural features and overload the suspension system. This caution, of course, applies to all devices but is most important where climbers operate at greater speeds.

Figure 3
Drill-Powered Traction Climber Equipped Stage

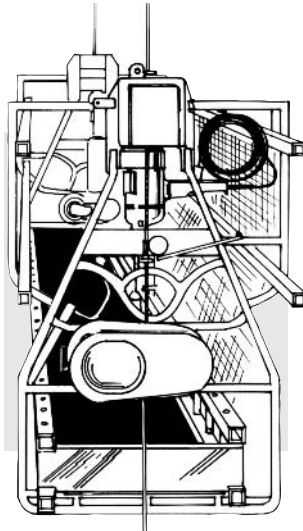


Figure 4
Powered Traction Climber Equipped Stage

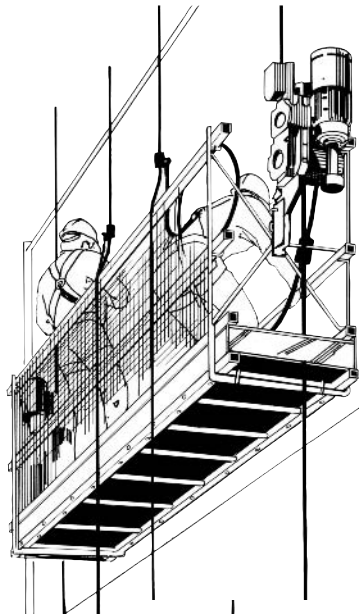
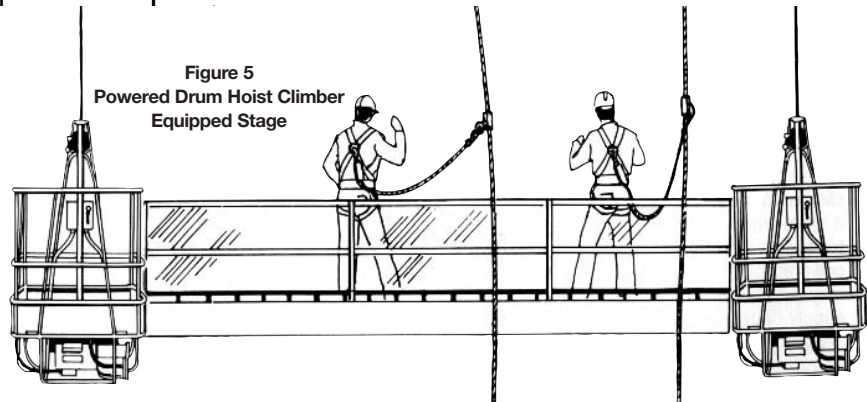


Figure 5
Powered Drum Hoist Climber Equipped Stage



2.5 Powered Drum Hoist Climber Equipped Stage (Figure 5)

This equipment is common in the industry today. One advantage is that the suspension lines are wound up on the drum of a hoist rather than extending to the ground. This keeps the free ends of suspension lines from crossing, catching on the building, entangling, or otherwise hindering safe operation. This feature improves the safety of the equipment. Although not common, other types of climbers can be equipped with a reel to provide the same feature.

2.6 Bosun's Chair (Figure 6)

Bosun's (or boatswain's) chairs were used for centuries on ships.

Originally equipped with a rope fall, the chairs required considerable physical effort to be raised and lowered.

Today with descent control devices or powered climbers, bosun's chairs can be used for various purposes in construction, repair, maintenance, and inspection.

In some cases, it may be safer and more efficient to use work cages equipped with powered climbers.

Whether equipped with a descent control device or power climber, all bosun's chairs must use wire rope support cables if

- the distance from the fixed support to the work platform will exceed 90 metres (295 feet)
- corrosive substances are used in the vicinity of the support cables, or
- grinding or flame-cutting devices are used in the vicinity of the support cables.

As with all suspended access equipment, a fall-arrest system (Figure 7) is essential with a bosun's chair. The system must be used at all times when a person is getting on, working from, or getting off the chair.

For more information on fall arrest, see the chapter on Personal Fall Protection in this manual.

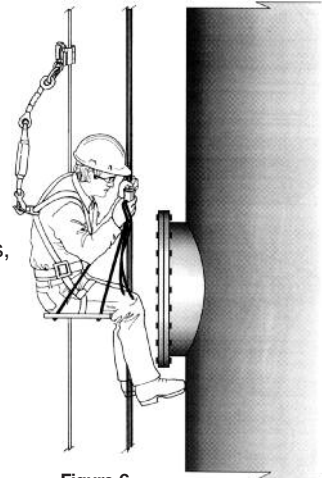


Figure 6

2.7 Bosun's Chair with Descent Control Device

(Figure 8)

This arrangement is commonly used in the window cleaning trade. It is very useful in situations where workers must progressively descend from one level to another. It cannot be used to climb. The main advantage of descent control devices is that they are light to carry or move and simple to rig.

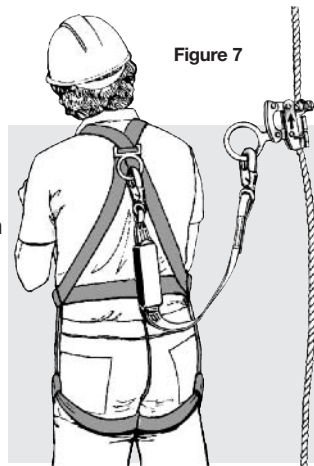
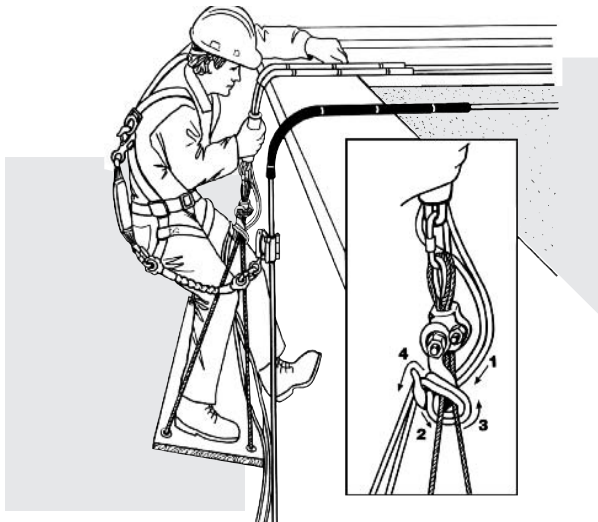


Figure 7

Figure 8
Bosun's Chair with Descent Control Device



It is standard practice for such devices to be reeved with two suspension lines. The reason is that the ropes are easily damaged and the second suspension line provides added safety. A second suspension line is mandatory for window cleaning applications.

2.8 Bosun's Chair with Powered Climber

(Figure 9)

These devices are fitted with a seat attached to a powered climber unit. They are often used for work which requires a considerable amount of travel in restricted areas where powered work cages would be cumbersome. They are compact in size and generally lighter than work cages. Inspection work is a typical application for these devices.

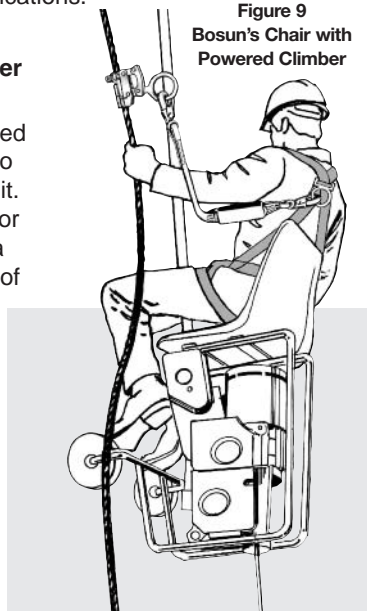


Figure 9
Bosun's Chair with Powered Climber

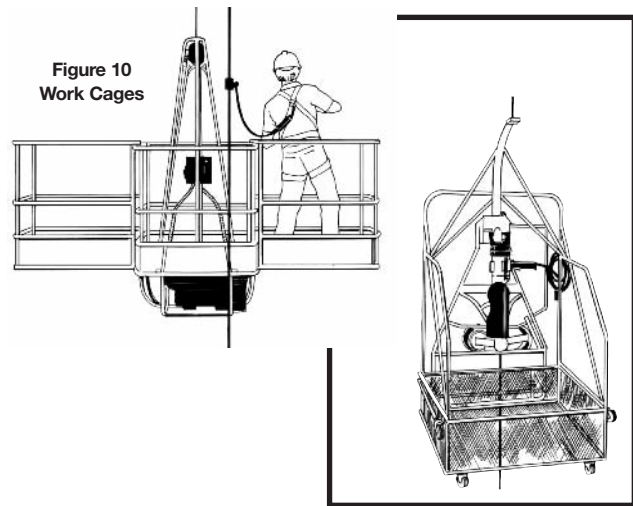


Figure 10
Work Cages

2.9 Work Cage with Powered Climber (Figure 10)

In construction, work cages are often used in place of bosun's chairs for both safety and efficiency. These devices are usually equipped with powered climbers similar to those used for stages. Some of the devices fold up for easy transport. Others may be equipped with platform extensions providing a wider working area.

3 COMPONENTS AND RIGGING

3.1 Planning and Selection of Equipment

When starting a new job on an unfamiliar site, always inspect the roof and work area before deciding on the equipment required.

The following are some of the points to check during inspection.

- Building height—you need this to determine the length of suspension lines and lifelines.
- Location, type, and capacity of permanent roof anchors.
- If there are no permanent anchors, what provisions are required to adequately anchor support cables as well as travel-restraint and fall-arrest system?
- Area available for set-up.
- Location of any electrical hazards.
- Roof capacity—is it capable of supporting all of the required equipment?
- Is there a parapet wall? Has it been designed to accommodate a parapet clamp outrigger system or will outrigger beams have to be set up on stands above the wall elevation to protect it from damage?
- How much overhang will be required for outrigger beams?

Once you have determined these and other site-specific conditions, select the suspended access equipment and fall-arrest system that will best accommodate the job.

Always ensure that the proposed set-up and equipment will meet the requirements of the Construction Regulation (O. Reg. 213/91) under the *Occupational Health and Safety Act*.

3.2 Platforms


Platforms of various types are illustrated in Figures 3, 4, and 5. Load ratings of platforms and platform combinations are available from manufacturers. Typical platforms have 500-lb or 750-lb ratings. The platform must be capable of supporting all loads to which it is likely to be subjected without exceeding the manufacturer's rated working load. The load includes air or water hoses and similar equipment suspended from the stage. We strongly recommend that only stages rated for 750 lb or greater be used on construction projects.


Each platform should be equipped with

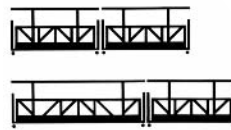
- an adequate guardrail system that includes
 - a securely attached top rail between 0.9 metres (36 inches) and 1.1 metres (43 inches) above the work platform
 - a securely attached mid-rail
 - toeboards
- wire mesh
- a skid-resistant platform
- adequately sized, securely attached stirrups.

On many platforms, the front guardrail (closest to the building face) can be lowered to accommodate the work being done.

It's good practice to use front guardrails in the fully raised position at all times. You must use them when the stage is more than 75 mm (3 inches) from the building facade. If the stage is less than 75 mm from the facade and properly secured to the face of the structure, you can lower the front guardrails.

 Stock platforms are available from most suppliers from 4 feet to 32 feet long in increments of 2 feet.

 Various combinations of shorter modular platforms are designed to be connected together (Figure 11). Use only manufacturer-designed connection methods.

 To ensure that the stage remains close to the facade during work, it must be secured to the building wherever possible, unless the stage is being raised or lowered.


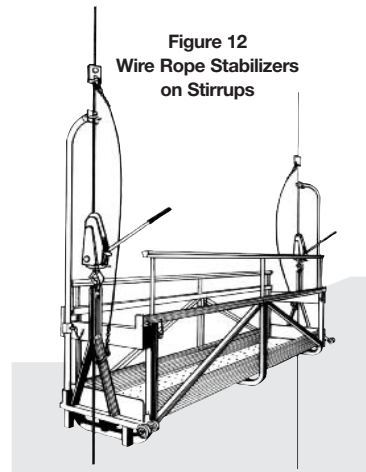
 The wire mesh [38 mm x 38 mm (1 1/2" x 1 1/2")] should be in good condition and fastened in position to cover the area from top rail to toeboard.

Figure 11
Typical Platform Modules

This will prevent debris and tools from falling off the platform and injuring personnel below.

Various platform accessories are available from suppliers to improve safety and operation. For example, guides or wire rope stabilizers attached to the stirrups (Figure 12) will reduce platform sway.



with the advice of the supplier and in accordance with manufacturers' recommendations.

of the platform (Figure 13) facilitate horizontal movement. Bumper or guide rollers attached to the front of the platform provide clearance around small obstacles and protect the building face from the platform. Special adjustable roller or castor systems are available for platforms used on sloping surfaces (Figure 14). This type of set-up should only be used

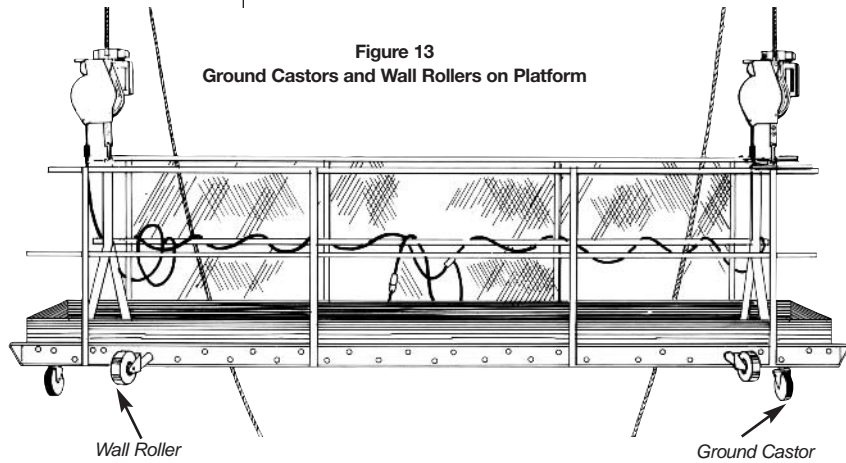


Figure 13
Ground Castors and Wall Rollers on Platform

Stirrups must be securely attached to the platform. This is usually done with a threaded rod or bolts. These should be equipped in turn with lock nuts or drilled and fitted with locking pins.

A suspended stage must be anchored to the building wherever possible, unless the stage is being raised or lowered. Newer buildings are equipped with mullion guides. Devices attached to the stage slide up and down the guides to reduce lateral movement. Mullion guides are usually not found on older buildings or buildings under construction.

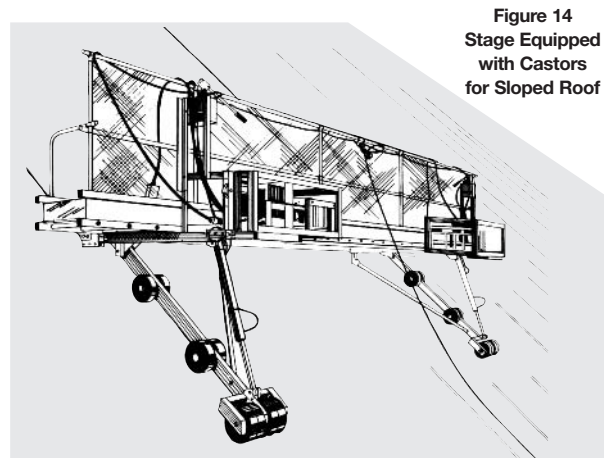


Figure 14
Stage Equipped with Castors for Sloped Roof

Most platform structures are manufactured from aluminum components for strength, light weight, and easy handling. However, aluminum platforms are not recommended where caustic or acidic materials and fumes may be encountered. In these instances special provisions must be made to protect the platform from the particular hazardous substance. Where aluminum platforms are exposed to caustic or acidic conditions, they should be rinsed off with clean water regularly and inspected regularly for signs of degradation or damage. Aluminum stages may be given a protective coating.

Components of the platform such as the main structure, handrails, and stirrups should be inspected regularly and any damage promptly repaired. Only competent persons should repair the platform structure. Welding repairs should be done only by a certified welder with the manufacturer's approval using proper equipment and procedures. Connector bolts, brackets, and shackles should be checked for wear and torque regularly and often.

3.3 Outrigger Beams

Various types of outrigger beams are in common use. Most beams are steel while others are aluminum. They have two or sometimes three sectional components to keep them light and portable.

The outrigger beam should be rated to withstand four times the maximum load applied without exceeding its ultimate unit stress. These beams are not indestructible, however, and should be used only in accordance with the manufacturer's or supplier's table of counterweights and allowable projections beyond the fulcrum for various suspension line loads. Adequate legible instructions for the use of counterweights must be affixed to the outrigger beam.

It must be understood that **outrigger beams have maximum allowable projections beyond the fulcrum due to strength limitations.** Consult the manufacturer or supplier if this information is not provided on the equipment.

Sectional outrigger beams must have a means of preventing pins from loosening and falling out (Figure 15). Otherwise, pins can work loose with movement of the stage and action of the climbers.

Beams should be free of any damage, dings or kinks since these can reduce structural capacity considerably.

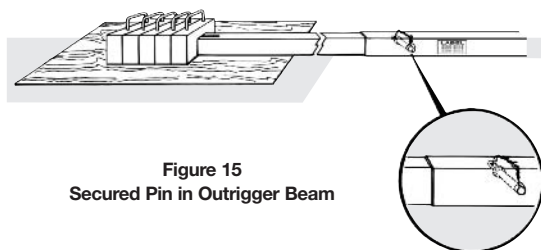


Figure 15
Secured Pin in Outrigger Beam

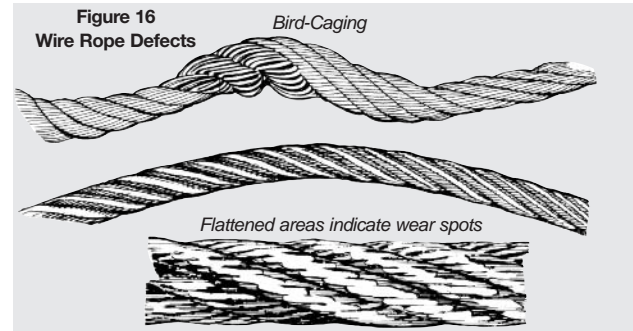
3.4 Counterweights

Counterweights range from 50 to 60 lb. each. Only manufactured counterweights compatible with the outrigger beam should be used. The counterweights should have a means of being secured in place on the beam. An adequate number of counterweights should be available to provide the counterweight capacity required for the

beam projection beyond the fulcrum, as discussed in Section 4.3.

3.5 Wire Rope

For suspension lines on any type of climbing equipment use only wire rope of the type, size, construction, and grade recommended by the manufacturer of the climbing unit. The minimum size of steel wire rope used for climbing devices on suspended access equipment is 7.8 mm (5/16 inch) diameter.



Take care to ensure that the solid core wire rope intended for some traction climbers is not replaced by fibre core wire rope. The compressibility of the fibre core can cause the rope to slip through the traction climber. Manual traction climbers use a wire rope of relatively stiff construction (usually 6 x 17). Powered climbers use a more pliable wire rope construction (usually 6 x 19 or 6 x 31).

Wire ropes should be free of kinks, birdcaging, excessive wear, broken wires, flat spots, or other defects (Figure 16).

When brazing the end of wire ropes, cut the core back 3 or 4 inches short to allow for movement in the rope and easier threading through the climber.

Wire ropes may be used as static lines or tieback lines for outrigger beams. In either case, the wire rope must be properly secured to adequate anchorage.

The use of secondary safety devices commonly known as "block stops" simplifies the installation of wire rope tiebacks. These devices must be installed, used, inspected, and maintained according to manufacturer's instructions.

Cable clips used with wire rope tiebacks or static lines should be the right size and number, torqued up tightly, and correctly installed (Figure 17).

Cable clips must never be used on fibre or synthetic rope unless the procedure is authorized by the rope manufacturer.

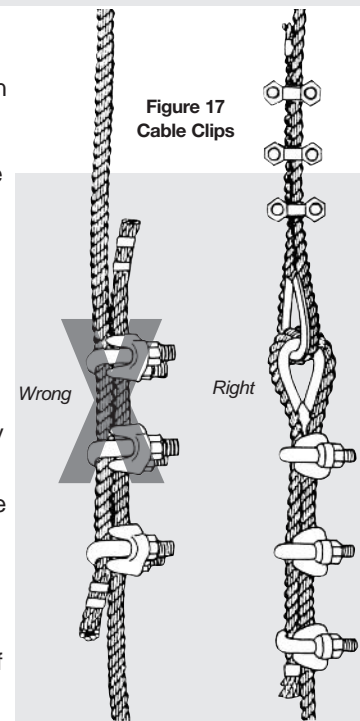


Figure 17
Cable Clips

Table 1 specifies the number of cable clips required for various types and sizes of wire rope commonly used for tiebacks and static lines. Although U-bolt clips are the most common, double saddle clips (sometimes called J-clips or fist grips) do not flatten the wire rope and are more appropriate to this application.

Note: Cable clips are not recommended for use on suspension lines. Loops in suspension lines should have thimbles and be either spliced or secured with a mechanically swaged fitting.

Table 1

INSTALLATION OF WIRE ROPE CLIPS			
Rope Diameter (inches)	Minimum Number of Clips	Amount of Rope Turn Back From Thimble (inches)	Torque in Foot-Pounds Unlubricated Bolts
5/16	3	11-1/2	30
3/8	3	11-1/2	45
7/16	3	11-1/2	65
1/2	3	11-1/2	65
9/16	3	12	95
5/8	3	12	95
3/4	4	18	130
7/8	4	19	225

Wire ropes used with suspended access equipment must have a safety factor of 10 against failure (the manufacturer's catalogue breaking strength). This applies to all wire ropes used in rigging the equipment, including suspension lines and tiebacks.

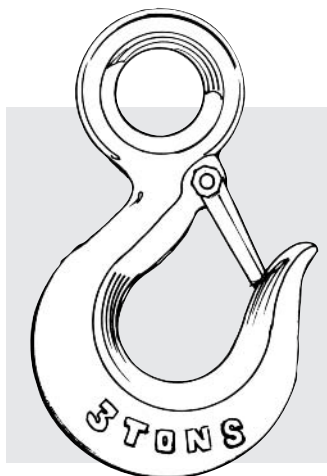
Wire rope suspension lines supporting a stage used for electric welding must be protected from the danger of welding current passing through them. This can be done by using an insulated thimble on the suspension line/outrigger beam connections and covering the climber and suspension lines in the vicinity of the stage with an insulating material such as a rubber blanket. The ground connection for the material being welded should be as close as possible to the welding zone. The deck and rails of the stage should be covered with insulating rubber and the stage should have rubber bumpers.

3.6 Rigging Hardware

Rigging hardware for use with suspended access equipment should be capable of supporting at least 10 times the maximum load to which it may be subjected. This applies to all hooks, shackles, rings, bolts, slings, chains, wire rope, and splices.

Shackles and hooks should be forged alloy

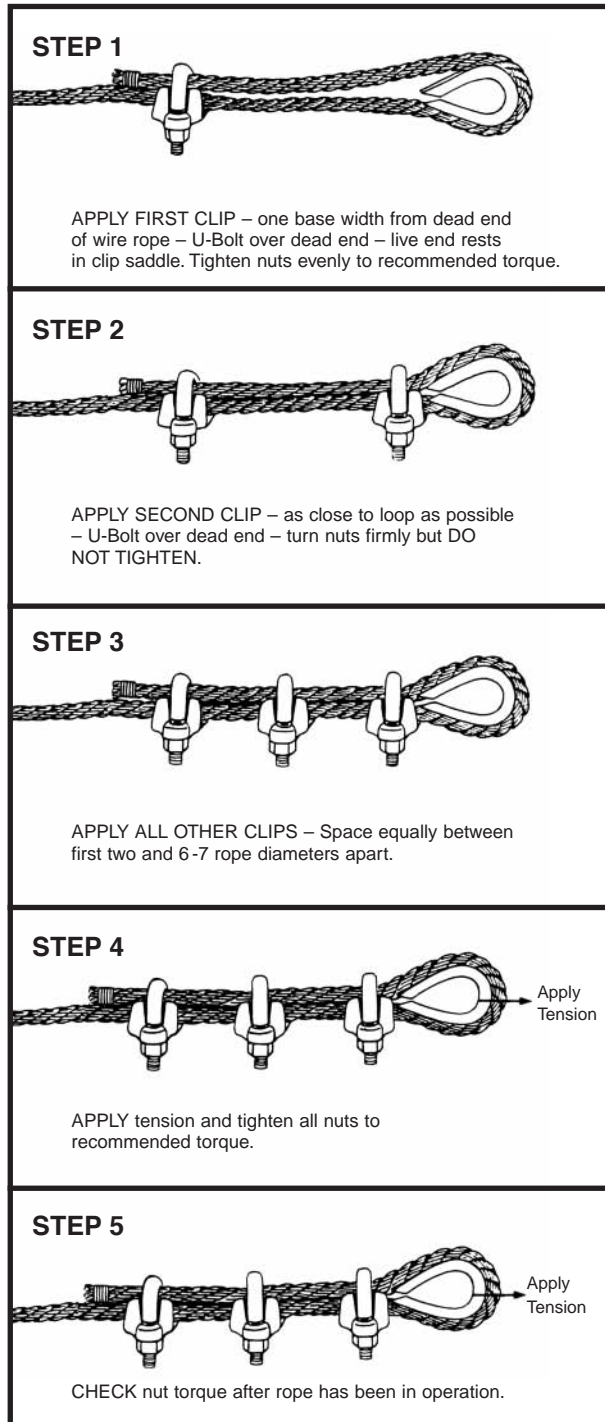
Figure 18
Forged Alloy Hook with Stamped Capacity



steel (Figure 18). The capacity of these devices for normal hoisting purposes is usually based on a safety factor of 5 and should be stamped on the device. For use with suspended access equipment, this capacity must be divided by two to ensure a safety factor of 10.

3.7 Manual Traction Climbers

The mechanical action of these devices is similar to hand-over-hand pulling on a rope. While one mechanism pulls, the other changes position to pull in turn. The jaws of the device grip the wire without damaging it. They are self-locking. As the load increases, their grip increases—the greater the load the tighter the grip.



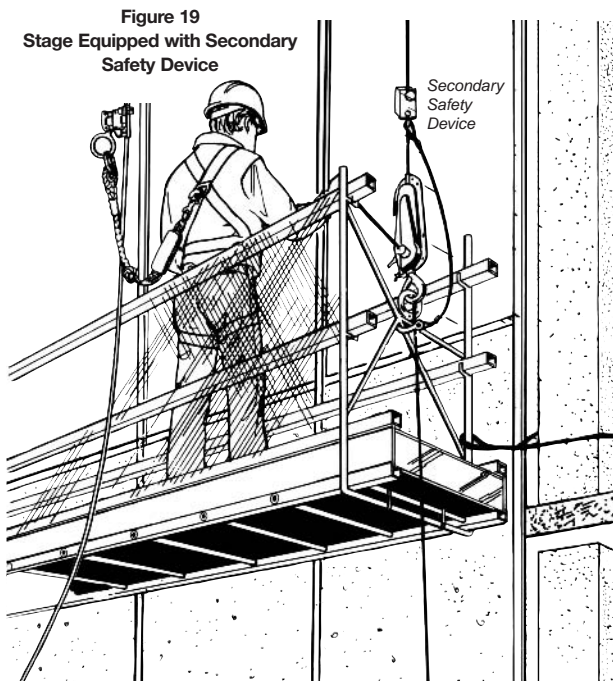
Lifting capacity varies with the size of the device. Check the manufacturer's literature to ensure that the capacity is adequate for the load. A maximum load rating for pulling and maximum load rating for hoisting will usually be specified in the literature. Use the load rating for **hoisting**.

Only the size, type, construction, and grade of wire rope specified by the manufacturer should be used with these climbers. Maintenance is usually limited to daily inspection and periodic cleaning. Field personnel should not try to repair these devices. Repairs should be left to an authorized dealer with factory trained personnel.

3.8 Secondary Safety Devices

A secondary safety device is a wire rope grabbing device that provides protection in case the wire rope connection or primary hoisting system fails. Figure 19 illustrates how the device is mounted on each wire rope above the hoist with a whip or sling connected to the stirrup of the stage. These devices may also be a fixed component on powered climbers.

As these devices advance on the wire rope their jaws open slightly to let the rope pass through. When a sharp downward pull is exerted, the jaws automatically close on the rope and grip it with a degree of tightness determined by the load.



3.9 Powered Climbers

Powered climbers come in a variety of sizes with different climbing speeds, power requirements, and safety devices. The majority are powered by electricity. Some operate at 115 volts, 60 Hertz, while others operate at 220 volts, 60 Hertz. Air- and hydraulic-powered systems are also available.

Most powered climbers have automatic overspeed brakes for situations where descent takes place too quickly. Most also have a manual system for lowering the stage in case

of power failure or other emergency. Workers using the stage should be fully instructed in the operation and purpose of these devices.

Manufacturers usually list a safe working load either on the device or in their literature. Along with this information the climbing speed will usually be noted. Climber lifting capacities range from 304 to 1,134 kg (750 to 2,500 lb.) and climbing speeds vary from 0.178 to 0.76 metres per second (15 to 35 ft/min). You must not exceed the rated working load of either of the two climbers on your stage. To ensure that you are not overloading the climbers, take the combined total of

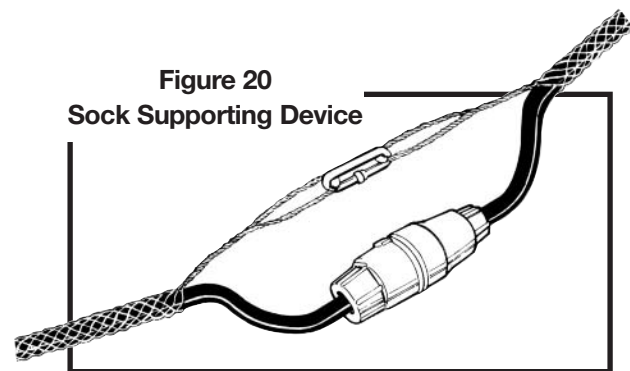
- a) half of the weight of the stage, motors, climbers, and power cables
- plus**
- b) the full weight of all the people, working materials, tools, equipment, and anything else that the stage may carry.

This combined total must not exceed the manufacturer's rated working load of each of your climbers taken alone.

Before selecting an electrically powered climbing device for a particular application, determine what circuits are available at the site. If circuits do not meet the voltage and amperage required, temporary wiring will be necessary to accommodate the climbers. Where the wiring runs are long, voltage drops may be so large that a portable step-up transformer is needed to maintain current levels so that the motor will not overheat.

Also consider the amount of climbing necessary for the job. Climbing speeds vary with the size of the climber. Small climbers carrying loads up near their safe working load limits over large distances may overheat and automatically cut off power. Workers should be advised why such situations can occur. It is usually because of improper climber selection, an inadequate circuit for the supply of power, or a cable too small for the length of run.

Power supply cables or cords must have wire heavy enough to minimize voltage drop in the line. Most supply cable is either 10 or 12 gauge 3 wire cab tire (neoprene rubber protected) depending on size of climber motors and length of run. Twist-lock outdoor male and female connectors should be used. "Sock" supporting devices should be used to relieve the strain on connections for long vertical cable runs (Figure 20).



3.10 Lifelines

Vertical lifelines must meet or exceed the requirements for performance, durability, impact strength, and elasticity specified in the current version of CAN/CSA Z259.2.

There must be an individual lifeline for each worker on a stage, platform, or chair. Each lifeline must have a separate anchor. Do not attach lifelines to the same anchor point as outrigger beam tiebacks.

Each lifeline must be long enough to reach the ground or a working level where a worker can exit from the equipment onto a solid, flat, level surface. Each lifeline must also have a means of preventing a rope grab from running off the end of the rope.

Before each use, lifelines should be inspected for damage from abrasion and chafing. When in use they should be protected from such damage.

Protection is necessary where lifelines are tied or anchored and where they extend over a wall, roof, or structural framing, as illustrated in Figure 21. Provide for protection when preparing for the job.

Lifelines must never be used to raise or lower material and equipment. When work is done, lifelines must be lowered to the ground, not dropped or thrown from the roof.

3.11 Fall-Arrest Equipment

Full body harnesses (not safety belts) must be used for all applications involving suspended access equipment. These devices transfer fall-arrest loads to the lower parts of the body such as thighs and buttocks instead of the mid-torso area containing a number of vital organs. The thighs and buttocks are not only more capable of sustaining the fall-arrest loads, but can also more comfortably and safely support the person awaiting rescue.

Lanyards must meet or exceed the requirements of the

current version of CAN/CSA-Z259. It is recommended that lanyards be fitted with locking snap hooks (Figure 22) or be spliced to rope grabs. Following this recommendation will reduce the risk of rollout (see section 5.5 in this chapter).

Shock absorbers must be used in any fall-arrest system. Shock absorbers should be manufactured to CSA Standard Z259.11-M92 and carry the CSA label. Shock absorbers may be attached to harnesses and lanyards with locking snap hooks in D-rings. It should be noted that shock absorbers can add as much as 1.2 metres (4 feet) to the fall distance before the fall is arrested.

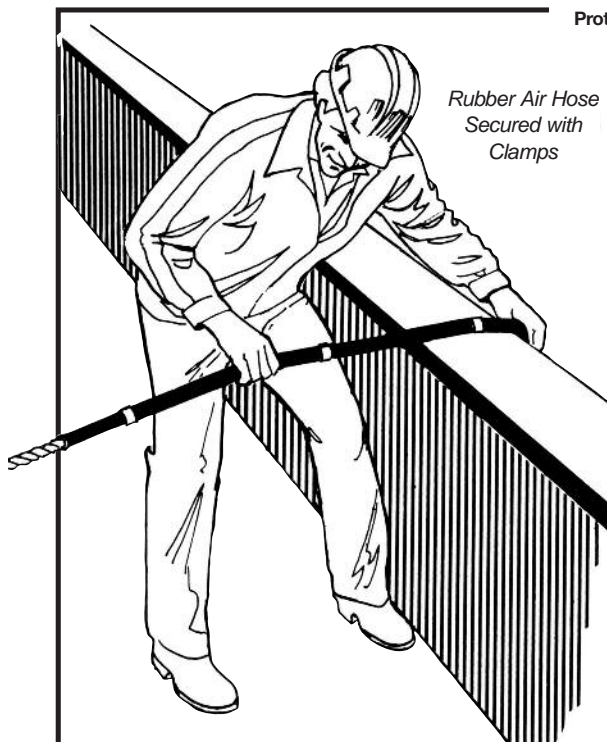
Fibre rope lifelines are not recommended where caustic or acidic solutions or sprays will be used, as in building cleaning, or where sparks from welding or cutting can cause damage. In such situations use wire rope lifelines. When using a wire rope lifeline, a shock absorber, connected between the "D" ring of the full body harness and the lanyard, or an integrated shock absorbing lanyard, must always be used to keep the forces on the body resulting from a fall arrest within acceptable and safe limits.

In addition, wire rope lifelines should be insulated whenever electric welding is taking place.

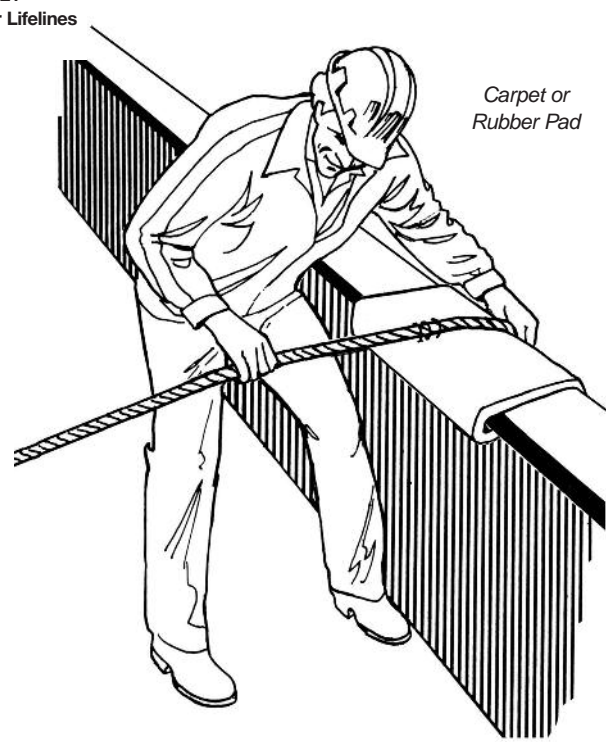


Figure 22
Locking
Snap Hook

Figure 21
Protection for Lifelines



Rubber Air Hose
Secured with
Clamps



Carpet or
Rubber Pad

4 SET-UP AND OPERATION

4.1 Two Independent Means of Support

A fundamental concept in the use of suspended access equipment is that there must be two independent means of support for workers on the equipment.

One independent means of support is the suspension system of the stage or bosun's chair (Figure 23). This usually consists of climbers, suspension lines, outrigger beams and counterweights or parapet clamps, and tiebacks secured to adequate anchorage.

The second independent means of support for the worker on a typical two-point suspension single stage is a fall-arrest system (Figure 24). This consists of a full body harness, lanyard, rope grab, and lifeline secured to adequate anchorage.

An alternative method for providing a second independent

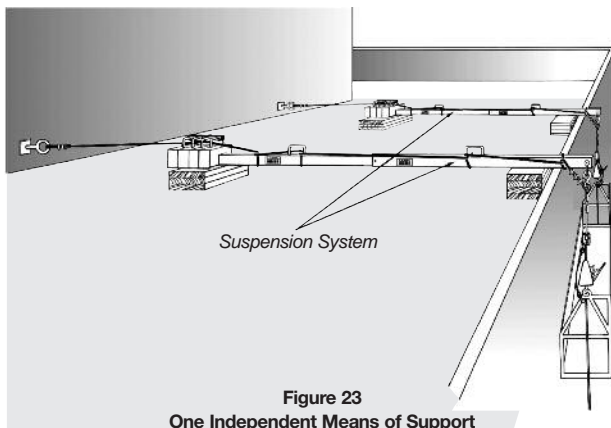


Figure 23
One Independent Means of Support

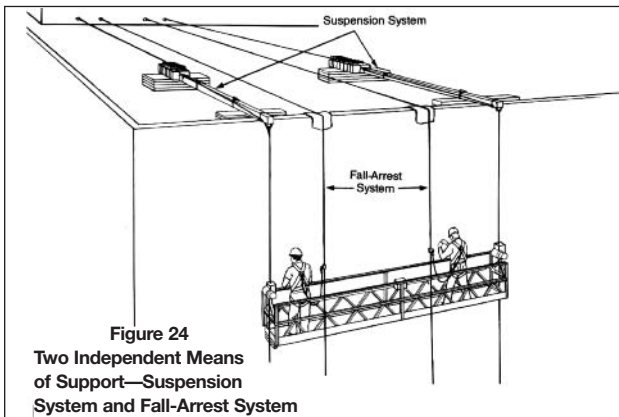


Figure 24
Two Independent Means of Support—Suspension System and Fall-Arrest System

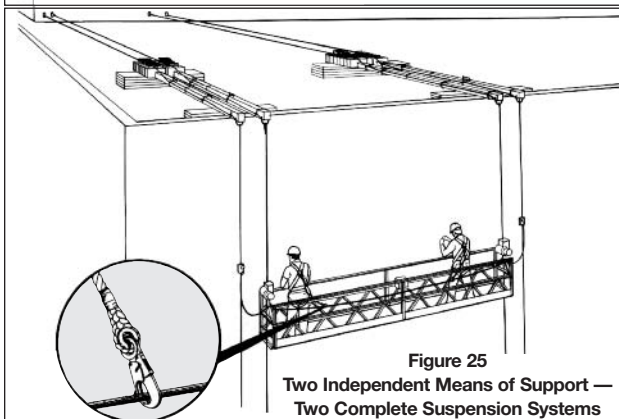


Figure 25
Two Independent Means of Support—Two Complete Suspension Systems

means of support is a second complete and independent suspension system (Figure 25). In this case, the worker should tie off directly to one of the stirrups or to a properly designed horizontal lifeline securely fastened to both stirrups.

This type of secondary suspension system must be designed by a professional engineer.

In practice two complete suspension systems are not used unless the application involves a tiered stage (Figure 26). In this case workers on the lower stage could not adequately be protected by a lifeline if the upper stage were to fall. Therefore the arrangement must be supported by two independent support systems. Workers on the lower stage must tie off to the stage they are on or the one above. Workers on the upper stage may tie off to the stage they are on or a lifeline.

Tiered stages must not be used unless the system is designed for the specific application by a professional engineer familiar with this type of equipment. The system must be rigged according to the design. Drawings of the design should be kept on-site for easy reference and inspection. In addition, the rigging should be checked by a professional engineer before the first drop is made.

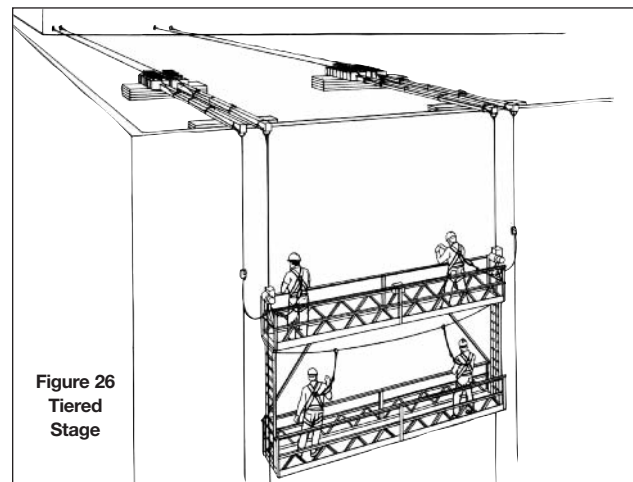


Figure 26
Tiered Stage

4.2 Outrigger Beams, Counterweights, and Tiebacks

Outrigger beams may be used for either stages or bosun's chairs. Procedures for both are essentially the same and in both cases the instructions on counterweight requirements and overhang limitations must be affixed to the outrigger beam being used.

Beams must be

- counterweighted to maintain a 4-to-1 safety factor against overturning or failure
- tied back to adequate anchorage as shown in Figure 27
- firmly attached to the counterweights
- free of damage, dings, or kinks
- light enough to be manually handled and transported.

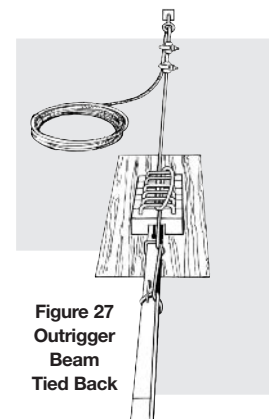


Figure 27
Outrigger Beam Tied Back

4.3 Loads and 4-to-1 Safety Factor

The dynamic loads involved and the unforgiving nature of suspended equipment require that the outrigger beam/counterweight arrangement must have a safety factor of 4 against overturning.

This means that the tipping tendency holding the beam from overturning must be at least 4 times the tipping tendency created by the suspension line load acting on the beam.

4.3.1 Suspension Line Load with Powered Climbers

For both suspended stages and bosun's chairs operated by powered climbers, the line load used to calculate the number of counterweights is the same as the manufacturer's rated capacity of the climber. The information plate on the climber should provide this information. The rated capacity must match the load limit information on the outrigger beams.

Powered climbers operating at speeds up to 35 feet per minute can load up very quickly if the stage or chair gets caught on an obstruction. In this situation the line load will reach the capacity of the climber before it automatically cuts out.

4.3.2 Suspension Line Load with Manual Climbers

Stages and bosun's chairs with manual climbers do not move nearly as quickly as powered climbers so there is no need to consider the capacity of the climber as the maximum possible suspension line load. We recommend the following criteria for establishing these loads on manually powered systems.

Two-point Suspended Stages: Calculate the weight of people, tools, and material expected to be on or suspended from the stage plus the weight of the stage, suspension lines, and climbers. Consider this load to be at least 1,000 lb. Then take 1,000 lb or the total weight of the suspended system— whichever is **greater**—as the suspension line load for calculation purposes. Consider this the load on **each** suspension line.

For example, if a stage weighs 200 lb, 2 workers weigh 400 lb, and climbers and other gear weigh 200 lb, the total load is 800 lb. In this case we recommend that each suspension line be rigged for 1,000 lb of line load. If the load had been 1,200 lb we would recommend rigging for a suspension line load of 1,200 lb **after checking with the supplier to ensure that the equipment is capable of taking such a load.**

Bosun's Chairs: Calculate the weight of the person, tools, materials, chair, suspension line and climber, but not less than 350 lb. The greater value then becomes the suspension line load for calculation purposes.

4.3.3 Calculation of Counterweight Load

Each outrigger beam should have an information label attached to it. This label will state the number of counterweights you need for a given loading and overhang situation. This information applies only to that beam, and to the counterweights provided by the manufacturer for use with that particular system. If the label is missing, you must not attempt to calculate the number of counterweights needed unless you know all the characteristics of that beam and of the counterweights being used.

The first operation in calculating the proper counterweight load is determining the appropriate suspension line load as discussed in 4.3.1 and 4.3.2.

For calculating the proper counterweight load, Figure 28a describes a formula for people with a good understanding of mathematics and the "law of the lever."

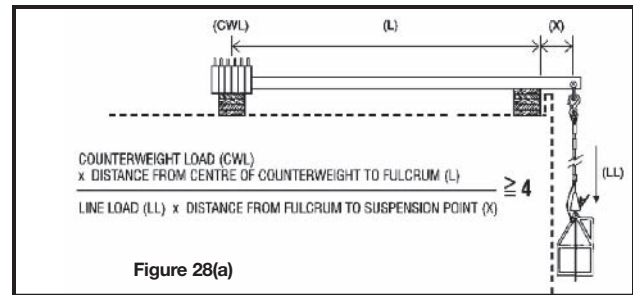


Figure 28(a)

We can also look at the problem in terms of what we have "working **against** us" versus what we need "working **for** us."

What we have working against us are the suspension line load and its distance from what we call the "fulcrum" or the tipping point. What we have working for us are the counterweights and the distance from the tipping point to the centre of the weights (Figure 28b).

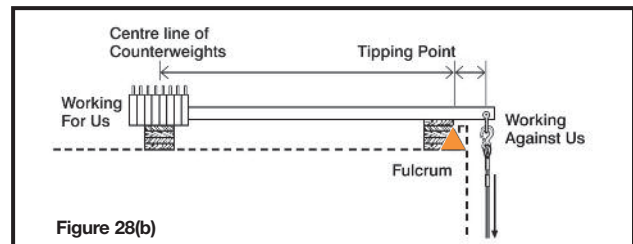


Figure 28(b)

Because of dynamic loads and the unforgiving nature of the equipment, we need to build in a safety factor. The safety factor is 4. We need 4 times as much for us as we have against us (Figure 28c).

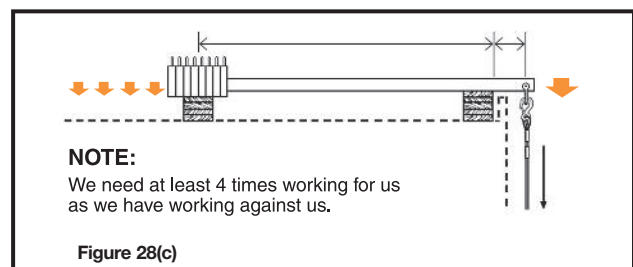


Figure 28(c)

A dynamic load is greater than a static or stationary load. We have all caught something dropped to us. The article is heavier when we catch it than when we simply hold it. The increase is due to the article moving. Its load when moving is called the dynamic load. This is one more reason why we need a safety factor.

The law of the lever says that the "tipping effect" or "moment" is equal to the load multiplied by the length of the lever. We have all used a pry bar to move heavy objects. The longer the bar the easier it is to move the heavy object, or the heavier the person on the bar the easier it is to move the object. This concept and the safety factor of 4 form the basis for our calculation.

If we assume our line load is 1,000 lb and the suspension point is located 1 foot beyond the outrigger beam's tipping point (Figure 28d), then the tipping force (moment) is:

$$1,000 \text{ lb} \times 1 \text{ foot} = 1,000 \text{ lb ft}$$

To resist this tipping force of 1,000 lb ft and at the same time ensure a built-in safety factor of 4, we need to have 4 times this value, that is, 4,000 lb ft, working for us.

If overall beam length is 12 feet, then the section working for us to resist tipping force extends from the tipping point to the far end, that is,

$$12 \text{ feet} - 1 \text{ foot} = 11 \text{ feet.}$$

However, in our calculation we can only consider the distance from the fulcrum or tipping point to the centre of the counterweights.

Let's assume that there are 400 lb of 50-lb counterweights each 1/2 foot in width. In Figure 28d you can see that the lever arm from the fulcrum to the **centre** of the counterweights can only be 11 ft – 2 ft = 9 ft. What we have working for us is: 400 lb x 9 ft = 3,600 lb ft.

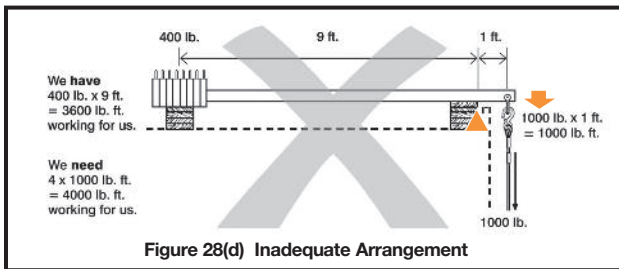


Figure 28(d) Inadequate Arrangement

This is less than the 4,000 lb ft we require. We will have to change something. We cannot change the suspension line load but we can change some of the other conditions.

If we reduce the distance that the suspension point extends out from the tipping point to 9 inches (.75 ft) the value of what we have working against us is:

$$1,000 \text{ lb} \times .75 \text{ ft} = 750 \text{ lb ft}$$

What we now need working for us is:

$$4 \times 750 = 3,000 \text{ lb ft}$$

If we keep the same number of counterweights, the lever arm working for us becomes 9.25 feet long. It gained 3 inches (0.25 feet) when the other side was reduced 3 inches (Figure 28e). We now have:

$$400 \text{ lb} \times 9.25 \text{ ft} = 3,700 \text{ lb ft}$$

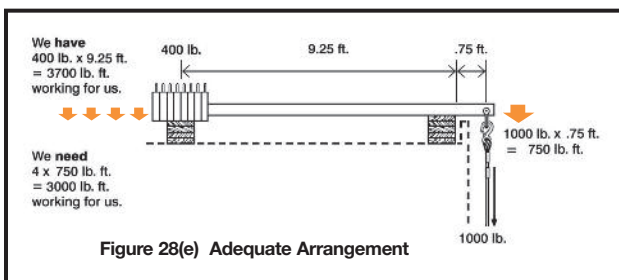


Figure 28(e) Adequate Arrangement

This would be satisfactory since 3,700 lb ft exceeds what we actually need (3,000 lb ft). See what a difference a few inches can make in this calculation!

Remember—the load line must remain vertical. This affects whether or not the beam projection can be reduced and by how much.

Another approach is to add more counterweights. If we add two more, our counterweights total 500 lb. However, our lever arm is reduced by 6 inches since the centre of the counterweights has shifted.

What we have working against us is still the same:

$$1,000 \text{ lb} \times 1 \text{ ft} = 1,000 \text{ lb ft}$$

What we need working for us is still:

$$4 \times 1,000 \text{ lb ft} = 4,000 \text{ lb ft}$$

What we have working for us is:

$$500 \text{ lb} \times 8.5 \text{ ft} = 4,250 \text{ lb ft}$$

Again, this would be satisfactory. We have more working for us than we actually need (Figure 28f).

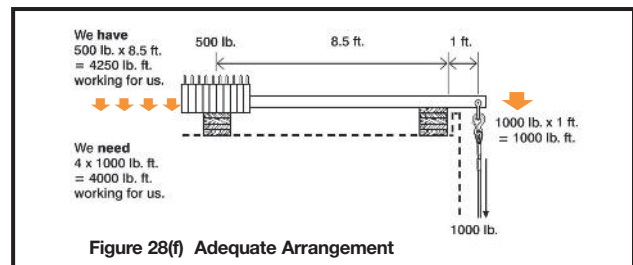


Figure 28(f) Adequate Arrangement

Before deciding whether or not to add more counterweights, keep in mind that every manufactured steel outrigger beam has a defined limit to the number of counterweights that can be placed and secured on it. This limit should be indicated on the beam label.

4.4 Counterweights

Counterweights vary in size and design from manufacturer to manufacturer. This is the main reason why one manufacturer's tables for counterweights cannot be used with another manufacturer's equipment.

Counterweights should be securely attached to the outrigger beam so that the vibration or movement of the beam will not dislodge or move them. Typical counterweight securing systems are shown in Figures 29 and 30.

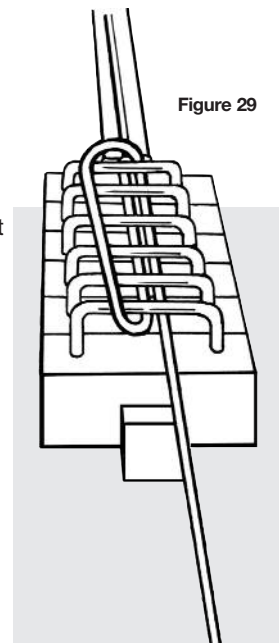


Figure 29

4.5 Roof Loads

Counterweights can overload roofs of light material such as metal roof deck. Most roofs are designed for the weight of the roof plus the design snow load which may range between 45 and 80 lb per sq/ft for areas in Ontario. Loads exerted by counterweights can be considerably greater than this and should be spread over a larger area by using plywood or planks (Figure 30). This also helps to reduce damage to built-up bituminous roofing.

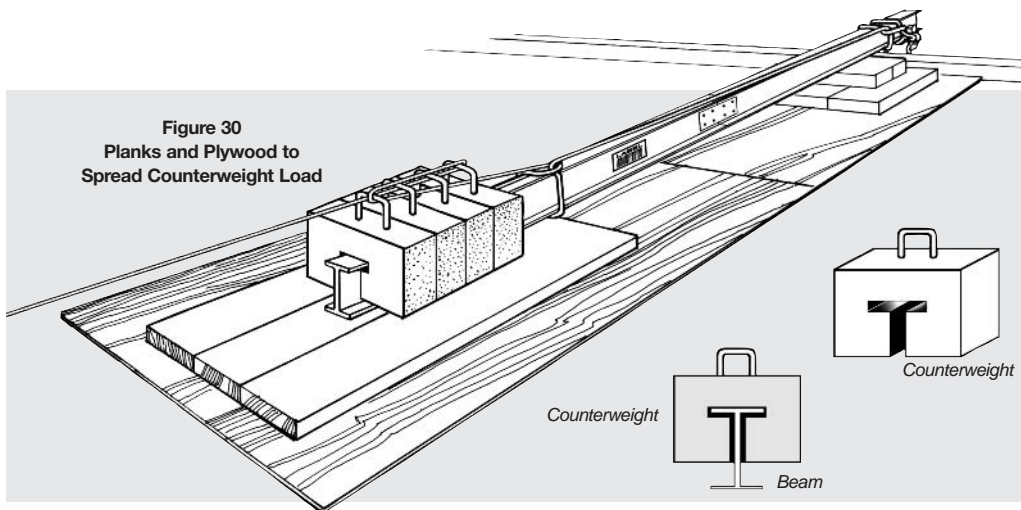


Figure 30
Planks and Plywood to Spread Counterweight Load

It is especially important to spread the loads on scaffold legs or the special support structure over a large area of the roof. Otherwise damage to the roofing material and possibly the deck itself may occur. Note planks and plywood under scaffold legs in Figure 31.

A scaffold system, or other specialized manufactured support system used to raise outrigger beams

4.6 Parapet Walls

Parapet walls often present an obstruction to outrigger beams that must be overcome by the use of scaffolding or a special support structure (Figures 31 and 32).

Note: The fulcrum is the point supported by the scaffold or support structure—not the edge of the roof.

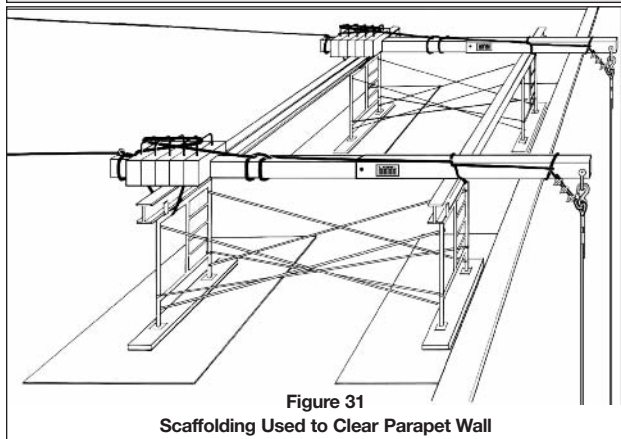


Figure 31
Scaffolding Used to Clear Parapet Wall

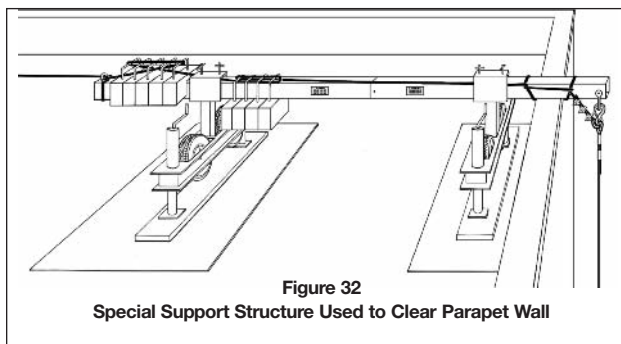


Figure 32
Special Support Structure Used to Clear Parapet Wall

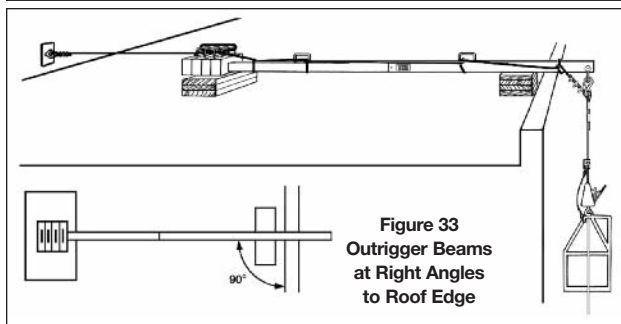


Figure 33
Outrigger Beams at Right Angles to Roof Edge

above the level of the parapet wall, must be designed by a professional engineer. A copy of the design drawings must be used to erect and inspect the system according to the engineer's design and must be kept on site as long as the system is in place.

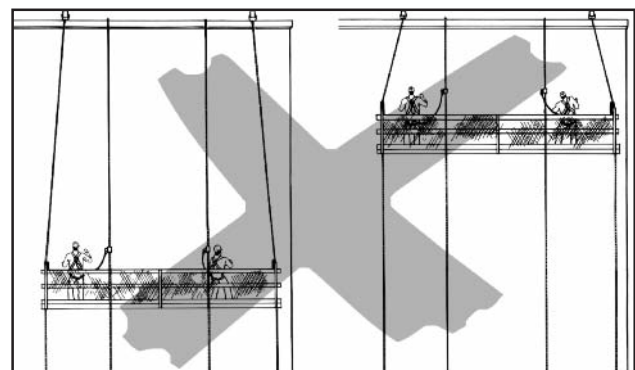
4.7 Outrigger Beams

Outrigger beams should be placed at right angles to the edge of the roof wherever possible (Figure 33).

If it's not possible to set up outrigger beams at right angles to the edge, the beams must be adequately secured or braced to resist any lateral movement while the system is in use.

Suspension points on the beams must be the same distance apart as stirrups on the stage. Position beams to ensure that spacing is the same. Failure to do so has resulted in many serious accidents.

Figure 34 illustrates what happens when the proper distance between outrigger beams is not maintained. The difficulty becomes serious as the stage nears the roof. At this point, sideways forces can move the outrigger beam, often causing a serious accident.



As the stage goes up, the angle of suspension lines increases, causing dangerous side loads.

Figure 34
Improper Spacing of Outrigger Beams

The pins on sectional outrigger beams must be properly installed and secured (Figure 15).

Wiring the pin in position or securing the nut on the pin with a cotter pin is also important. If the pin is not

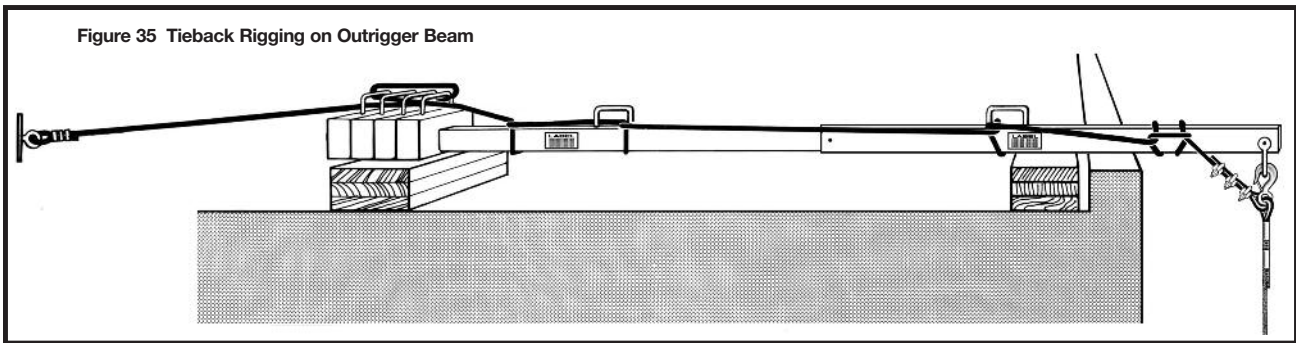


Figure 35 Tieback Rigging on Outrigger Beam

secured, vibration can easily dislodge it and make the beam come apart. This is especially important where manual climbers are used because the uneven jacking action of the climbers can apply intermittent loads to the beam and easily shake out a loose pin. This requirement also applies to shackle pins and eyebolts used on outrigger beam systems.

4.8 Tiebacks

Tiebacks should extend from the thimble of the suspension line back along the outrigger beam, with at least one half-hitch tied around the beam through the handles on each section. Tiebacks should then loop around the counterweight handles if they are so equipped, and then extend on back to an adequate anchorage (Figure 35).

Wire ropes are recommended for tiebacks with all suspended access systems. Fibre rope tiebacks are considered suitable for stages equipped with manual traction climbers. If fibre rope tiebacks are used, they should be 3/4-inch diameter polypropylene. Tiebacks for bosun’s chairs should be 5/8 inch diameter polypropylene rope. Other manufactured rope that equals or exceeds the impact resistance, elasticity, and UV protection of 16-millimetre (5/8 inch) diameter polypropylene rope can also be used. Nylon is not recommended because it stretches too much and manila rope is not recommended because it is much more subject to deterioration.

Wire rope used for tiebacks should be at least equal in size to the wire rope used for the climber. After wire rope has been used for tiebacks it should not be used for suspension line because of damage and deformation from cable clips, bends, and hitches.

Wire ropes should be fastened with cable clips in the correct manner (Figure 17) and recommended number (Table 1). Polypropylene rope should have either a spliced loop and thimble with a safety hook or shackle or be tied using a round turn and half-hitches (Figure 36) or a triple bowline knot (Figure 37). Knots may reduce the safe working load of the ropes depending on the means of securing and are therefore a less desirable alternative. Protect fibre rope from sharp bends. Figure 38 shows one method.

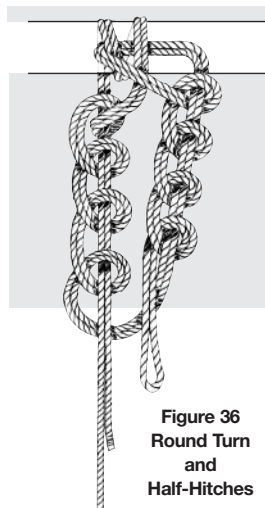


Figure 36 Round Turn and Half-Hitches

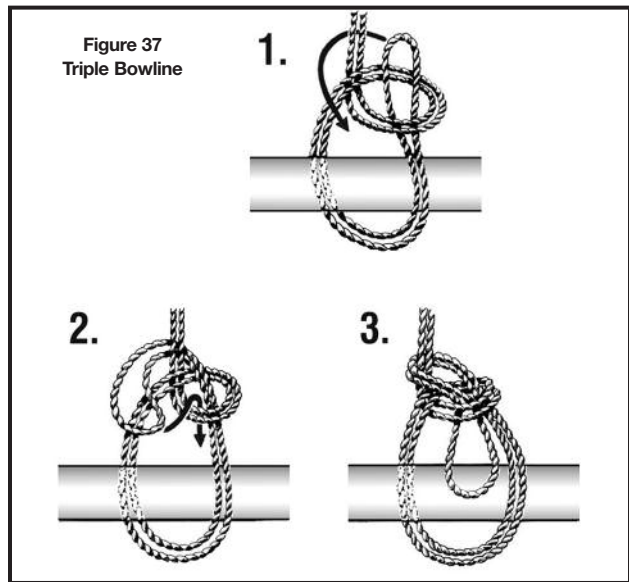
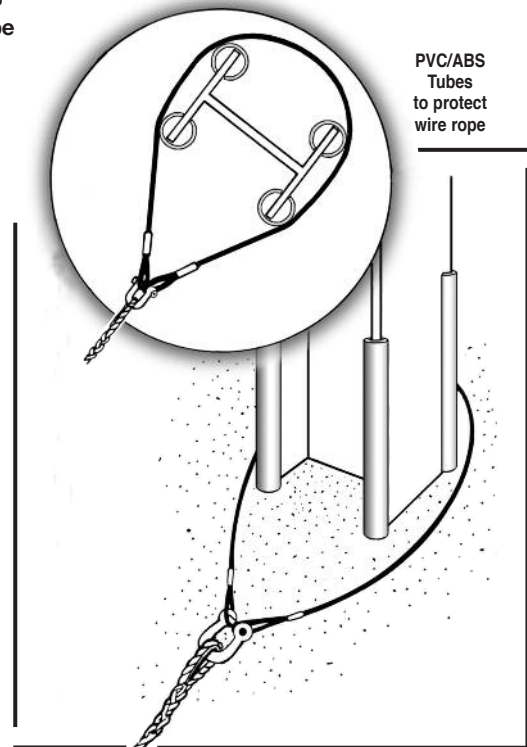


Figure 37 Triple Bowline

Where scaffolds are used for support structures, the tieback line should also be looped around the top of the scaffold (Figure 31).

Figure 38 Wire Rope Sling to Protect Fibre Rope



PVC/ABS Tubes to protect wire rope

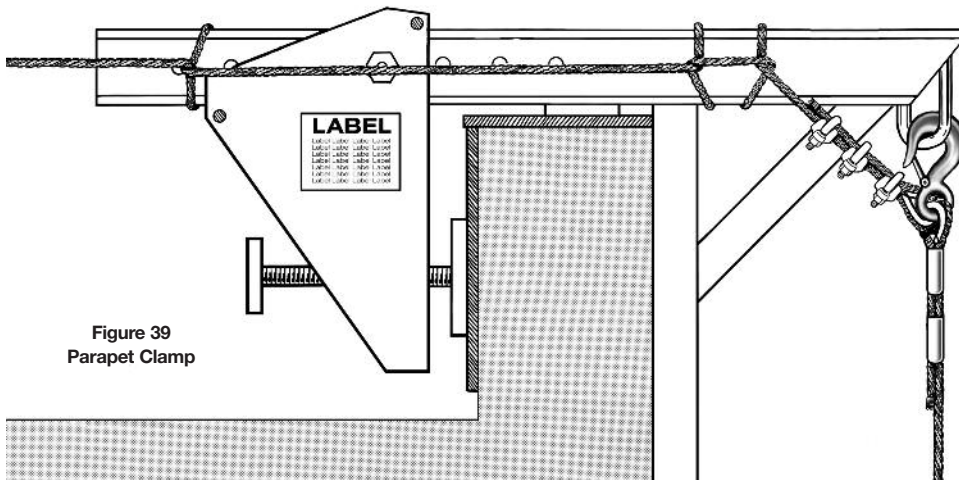


Figure 39
Parapet Clamp

4.9 Adequate Anchorage for Tiebacks

Adequate anchorage for tiebacks includes

- the base of large HVAC units
- columns on intermediate building floors or stub columns on roofs
- designed tieback systems such as eye bolts and rings
- large pipe anchorage systems (12-inch diameter or greater)
- large masonry chimneys
- roof structures such as mechanical rooms
- parapet clamps attached to reinforced concrete parapet walls **on the other side of the building.**

Never tie back to

- roof vents or “stink pipes”
- roof hatches
- small pipes and ducts
- metal chimneys
- TV antennas
- stair or balcony railings.

4.10 Parapet Clamps (Figure 39)

Where parapet walls are constructed of **reinforced concrete** or **reinforced masonry**, parapet clamps may be used. Before using any type of parapet clamp, obtain confirmation from the owner of the project that the parapet has been constructed with sufficient strength and performance characteristics to support the intended clamp.

Clamps must always be installed according to the manufacturer’s drawings and written instructions. Ensure that clamps are securely fastened to the parapet wall and tied back to an adequate anchorage in a manner similar to tiebacks for standard outrigger beams.

5 FALL PROTECTION

A fundamental concept in the use of the suspended access equipment is that **there must be two independent means of support for each worker using the equipment.**

The first means of support is the access equipment itself. The second is provided by an appropriate fall protection system consisting of a full body harness, lanyard, shock absorber, rope grabbing device, and lifeline, as illustrated

in Figure 40.

A fundamental concept in the use of any type of fall protection system is that it must be fully rigged, in place, properly adjusted, and worn by all workers

- while they are setting up and taking down the suspension equipment and working within 2 metres (6 feet) of the perimeter edge;
- while they are getting on and off the suspended access equipment; and

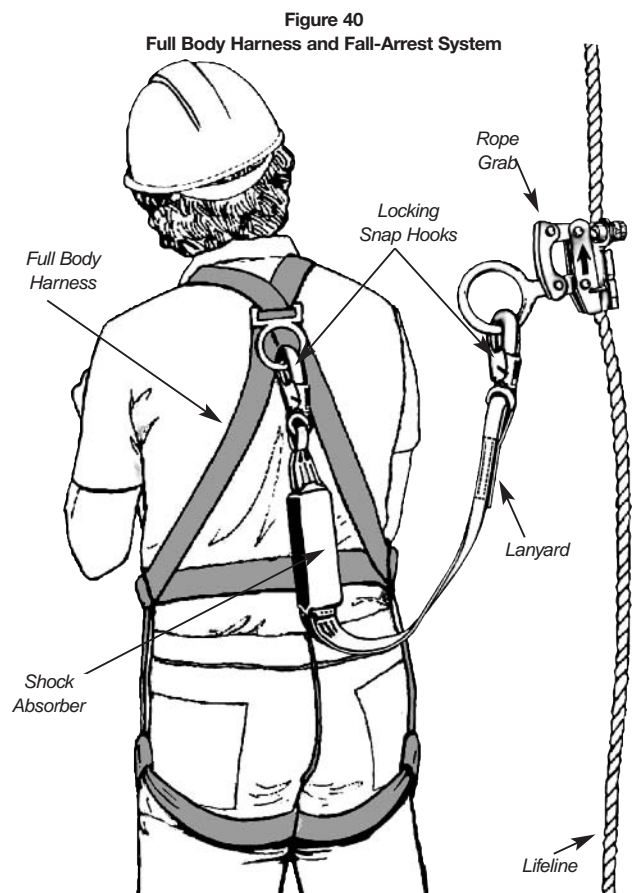


Figure 40
Full Body Harness and Fall-Arrest System

- at all times while they are on the equipment.

5.1 Fall Protection Planning

The pre-job inspection must determine not only the suspended access equipment to be used but also the proposed fall protection system.

When assessing fall protection requirements, check the following points.

- Is there a parapet wall higher than 1 metre (3 feet) around the roof perimeter?
- Are engineered anchors installed on the roof? How many are there? Where are they located? How far are

they from the set-up area?

- If there are no engineered anchors, are any existing structures big and strong enough to serve as anchors? An adequate anchor should be capable of supporting the weight of a small car (about 3,600 pounds).
- Are there any sharp edges requiring lifelines to be protected?

Fall protection planning must include

- type of fall protection equipment to be used
- type, length, and number of lifelines required
- travel restraint or warning barriers to be used when setting up or dismantling the suspended access system on the roof
- fall protection procedures to follow while setting up, getting on, getting off, working from, and dismantling the suspended access equipment.

Finally, all horizontal and vertical work surfaces where the suspended access equipment will be assembled, operated, and dismantled must be evaluated to determine escape, rescue, and other emergency procedures in the event of mechanical failure or breakdown.

5.1.1 Fall-Arrest Rescue Planning

Before any fall-arrest equipment is used on a construction project, the employer is legally required to have in place a written procedure outlining how to rescue a worker involved in a fall arrest. This procedure is in addition to those required by law to cover general emergency response on a project.

A worker hanging in harness after a fall arrest must be rescued and brought to a stable work surface, platform, or ground within 30 minutes. Left suspended for more than 30 minutes, the worker may experience increasing discomfort, nausea, dizziness, and fainting. If left suspended for a prolonged period of time, the worker may have heart and breathing difficulties and may even die.

To ensure timely, effective rescue, an employer may create generic procedures to cover all potential fall rescue requirements for the company's typical work.

The employer must then

- provide staff training in the procedures
- ensure that the procedures are reviewed and modified as necessary to meet specific job conditions
- provide staff training in these modified, site-specific procedures.

Use the following checklist to prepare rescue procedures for workers involved in fall arrest.

- Is there a safe practical means of self-rescue? Can a worker involved in fall arrest reach a work platform, ground, or other safe place? Is any special equipment or training necessary for self-rescue?
- How will the worker communicate his or her predicament to other workers?
- What is the procedure when workers see a co-worker hung up in fall arrest? Who should be notified and how? What

information needs to be conveyed? What should be done before help arrives?

- In an arrested fall from the highest point on the project, can the worker be reached by ground? Is there an adequate ladder or other device for rescue? Where is the equipment stored and who has access to it?
- Can a suspended worker be rescued from a level above or below? Is access unobstructed? Is a key necessary? Is there a way of quickly removing a window or other feature to reach the worker?
- If a suspended worker can't be reached from ground, another level, or a work platform, what specialized rescue equipment is needed? Are workers trained to use this equipment?
- What procedures are in place to rescue a suspended worker who is unconscious, injured, or otherwise unable to assist rescuers?
- What service, private or public, is available to aid in high-reach rescue? Has the service been notified and supplied with project information such as location, access, size, height, and available anchorage? Is the phone number of the service posted where everyone can see it? Have employees been advised to contact the service when high-reach rescue is needed?

5.2 Fall Protection Systems

There are two main types of fall protection systems:

- 1) fall prevention
- 2) fall arrest.

5.2.1 Fall Prevention Systems

Fall prevention is a system that prevents a worker from gaining access to a known fall hazard. A guardrail is one example.

Fall prevention is primarily used around areas on the roof where workers set up or take down the suspension system. It can also be used to protect personnel working on balconies or similar structures.

A parapet wall 0.9 metres (3 feet) high or higher surrounding a roof provides fall prevention. This is equivalent to having a guardrail around the perimeter. Workers can work near the edge of the roof without additional protection as long as they don't reach over or beyond the parapet wall. Otherwise they must wear appropriate fall protection equipment and be properly tied off (Figure 41).

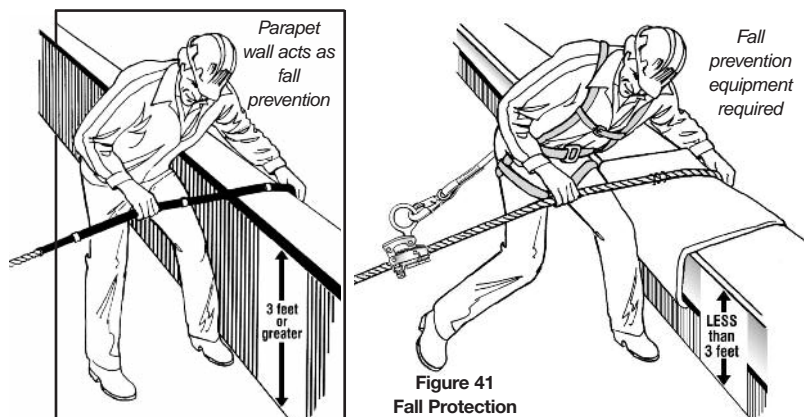


Figure 41
Fall Protection

A bump line or warning barrier can be set up 2 metres (6 feet) from any perimeter edge. Inside this cordoned-off area, workers do not require fall protection equipment. The barrier acts as a physical boundary by keeping unprotected workers away from the perimeter.

Where no bump or warning line is used, or where the work requires workers to be less than 2 metres (6 feet) from the edge, a travel-restraint system is required. This has all the same components as a fall-arrest system—full body harness, shock absorber, lanyard, rope grab, and adequately anchored lifeline (see 5.2.2). The difference between the two systems is how they are used.

The lifeline in a travel-restraint system must have a positive stopping device or knot tied in it to prevent the rope grab from travelling beyond that point. The device or knot must be positioned so that the distance back to the anchor point, plus the combined length of the rope grab, lanyard, and D-ring on the harness, is less than the distance from the anchor point to the edge of the work surface. With the system arranged in this way, a worker falling toward the edge will be stopped before going over the edge.

5.2.2 Fall-Arrest Systems

Workers getting on, getting off, or working from suspended access equipment must wear a fall-arrest system and be properly tied off to an adequately anchored lifeline. This also applies to workers working on balconies or similar structures without other means of fall protection.

A fall-arrest system must include

- a **full body harness** that meets or exceeds the

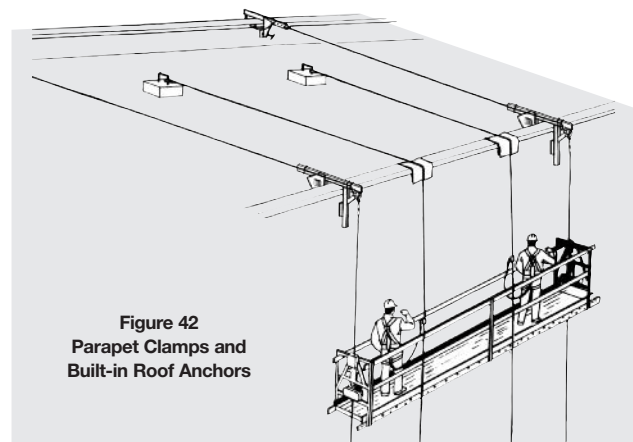


Figure 42
Parapet Clamps and
Built-in Roof Anchors

- current CSA standard
- a **shock absorber** that meets or exceeds the current CSA standard and is attached to the D-ring on the harness
- a **lanyard** that meets or exceeds the current CSA standard and is connected to the free end of the shock absorber and properly connected to the connecting ring of a rope grab
- a **rope grab** properly attached to an adequate vertical lifeline
- a **vertical lifeline** that meets or exceeds the current CSA standard and is properly secured to an adequate anchor

- an independent **anchor** which has been designed by a professional engineer for that purpose or which a competent worker can reasonably consider strong enough to support the weight of a small car (about 3,600 pounds).

In cases where the second means of support consists of a second, properly designed, fully rigged, and complete suspension system, workers can tie off directly to the suspended access equipment, as per design specifications for that particular system.

5.2.3 Fall Protection Training

Employers must ensure that any worker who may use a fall protection system is properly trained in its use and given adequate oral and written instructions by a competent person.

Training should include, but not be limited to,

- basic inspection, care, and maintenance of personal fall protection equipment
- proper methods of assembling, putting on, and adjusting equipment
- how to protect, handle, and secure lifelines
- safe versus unsafe anchor points
- procedures for tying off
- explanation of all work procedures that require fall protection
- explanation of company policy regarding mandatory use of fall protection on the job.

Employers must keep written records of all employees trained in fall protection.

5.3 Lifelines

Each lifeline must be tied back to an adequate anchorage. In practice, adequate anchorage is usually a matter of judgment rather than calculated capacity. As a rule of thumb, the anchorage should be capable of sustaining the weight of a small car.

On new construction, lifelines usually can be secured to exposed structural components such as beams or columns. On existing buildings adequate anchorage includes the points itemized in section 4.9.

Each lifeline must be tied off to an adequate anchor point separate and independent from the anchor points used for other lifelines and for tiebacks (Figure 42). Where there aren't enough independent anchor points to meet this requirement, an anchoring system must be designed by a professional engineer.

5.4 Protection for Lifelines

Lifelines must be protected from abrasion or chafing and from sharp corners which can break the lines under heavy shock loads.

A spliced eye and thimble, complete with a safety hook, is the recommended connection device. However, where the rope must be tied to the anchorage it is recommended that the rope be doubled back and tied with either a round turn and half-hitches (Figure 36) or a triple bowline knot (Figure 37).

Figure 43
Lifeline Secured to Counterweight at Ground Level

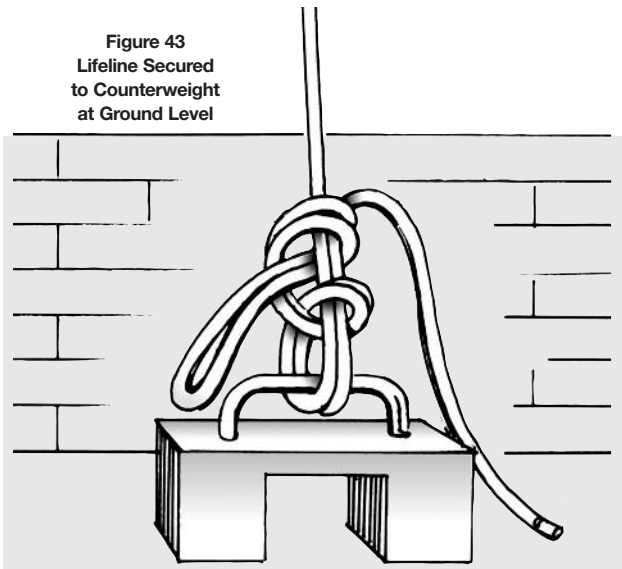
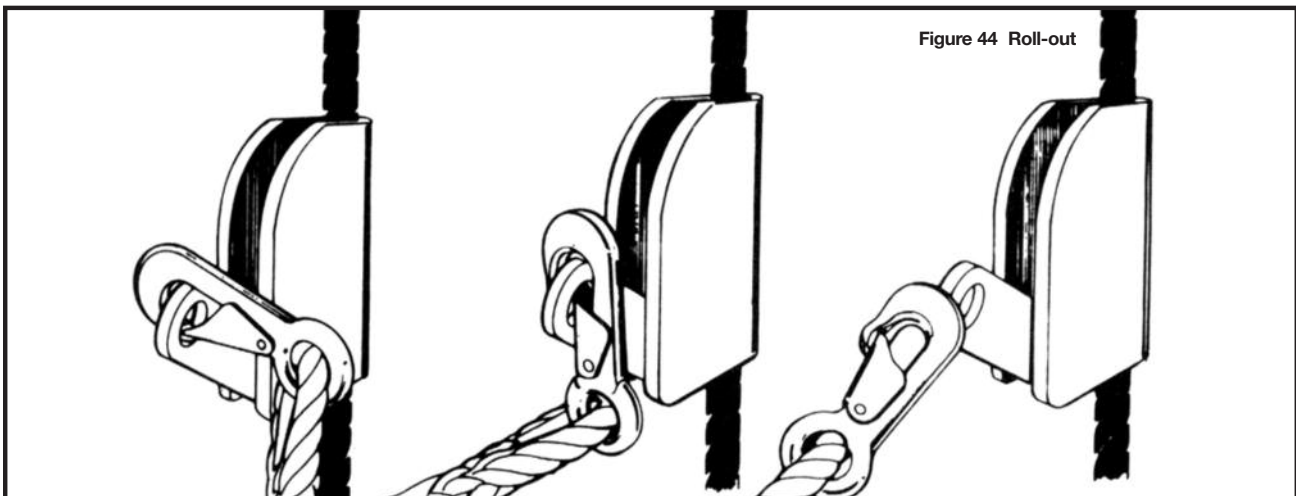


Figure 44 Roll-out



Although tying to the anchorage with knots is necessary in some situations, it is not recommended where the spliced eye and safety hook can be used. Knots may reduce the load-carrying capacity of the rope significantly.

Lifelines must also be protected from abrasion where they pass over a parapet wall or the edge of a roof. A rubber hose clamped to the lifeline to hold it in position is an effective means of providing protection. Rubber mats or carpeting also provide protection but should be fixed to the lifeline or be wide enough to allow for considerable shifting of the lifeline because of wind or worker movement below (Figure 21).

The lifelines should be reasonably taut. Loose coils on the roof should be lined out. Lifeline anchors should be perpendicular to the roof edge at the point where the lifelines drop over. The anchor point should be a reasonable distance from the roof edge—preferably 3 metres (10 feet) or more. This will allow the rope to absorb more energy in the event of a fall arrest at the roof edge.

Lifelines must also be protected from entanglement in traffic on the ground below or in construction equipment such as tower cranes. This can be done by tying the lifeline to the structure at ground level or weighting it down with counterweights (Figure 43). Always allow enough slack for the movement of workers on the stage.

5.5 Lanyards and Rope Grabs

Lanyards should be attached to the lifeline by a rope grab. The rope grab should meet the requirements of CSA Standard Z259.2.1.

Rope grabs and lanyards should be attached by a locking snap hook, a karabiner looped through a spliced loop and thimble, or a loop and thimble spliced into the rope grab ring. These methods will prevent “roll-out.”

Roll-out can occur when a regular snap hook attached to a small ring in the connection system releases itself under load (Figure 44). Small rings are sometimes found on older rope grabs.

5.6 Full Body Harness

With suspended access equipment, it is a legal requirement in Ontario to wear a full body harness—not a safety belt. The harness absorbs fall-arrest loads at the thighs and buttocks rather than the upper abdomen and chest where many of the body’s vital organs are located.

Lanyards should be attached to shock absorbers which should, in turn, be attached to the full body harness. The attachment should be a locking snap hook or a spliced hook loop and thimble. Looping a splice around a D-ring is **not** recommended.

The fall-arrest system must be in place and properly rigged, with attachments suitably adjusted, **before** the worker gets on the suspended access equipment. The worker must wear the fall-arrest system and be properly tied off at all times when getting on, using, or getting off the suspended access equipment.

6 Checklists

The following list identifies points which should be checked before anyone uses suspended access equipment.

- Operator knowledgeable and competent to operate the equipment involved?
- All required components available, properly rigged, and in good condition?
- Failsafe devices such as rope grabs, secondary safety devices, and overspeed controls installed and operating?
- Power supplies for climbers adequate, grounded, and secured?
- All tiebacks for outrigger beams, parapet clamps, and lifelines properly secured to adequate anchorage capable of supporting 10 times the applied load?
- Adequate number of counterweights securely attached to outrigger beams?
- Fibre ropes protected from chafing and abrasion?
- Emergency rescue arrangements planned, prepared, and communicated to everyone involved?
- Access to and from the work area planned and arranged?

The answer to each of these questions should be yes.

SUSPENDED ACCESS EQUIPMENT

DAILY CHECKLIST

WEEK ENDING _____

Planning Checklist Items

Jobsite _____ Location _____ Contact _____ Position _____ Log Book _____
 Competent Person _____ Roof Sketch _____ Access _____ Control _____ Storage _____
 Equipment Requirements _____ Personnel Req'd _____ Training Req'd _____ WHMIS _____ Work Plan _____
 Public Protection _____ Hoarding/Barricade _____ Signage _____ Inspection _____ Building Height _____
 Type of Work _____ Restoration _____ Caulking _____ Cleaning _____ Other _____
 Building Height _____ Obstructions _____ Landing Area _____ Anchorage _____ Adjacent Powerlines _____

Support Checklist Items

BEAMS	M	T	W	Th	F	SWINGSTAGES	M	T	W	Th	F	FALL-ARREST SYSTEM
Length of Overhang						Power Cable & Yoke						Daily or Frequent Checks
Number of Weights						110v Box						Separate Anchor Point
Connecting Pins, Lock Wire						Support Cables						Knot
Support Cable & Hooks						Cradles/Stirrups						6 Feet from Edge
Parapet Clamps						Motor Mounts						CSA Rope Grab
Beam Supports						Motor Daily Checks						CSA Lanyard
Beam Label						Overspeed Check						CSA Shock Absorber
TIEBACKS						GROUND CHECK						CSA Body Harness
Through Thimble						Fence/Barricades						Lifeline
Through Handles						Free of Garbage						Rope Protection
Through Weights						Equipment Secured						Locking Snap Hooks
Block/Drop Stops						Cladding/Hoarding						Trained in Using
Wire Rope Clips						Walkthrough Scaffolding						Line Ground Protection
Clevises/Shackles						SCAFFOLDING						Lines Perpendicular
Anchoring Points						Lock Pins						
Knots						Vertical Braces						
Clear Path to Edge						Horizontal Braces						
Edge Protection						Guardrails						
POWER CABLE						Planks						
Tied Back						Base Plates						
Edge Protection						Tie-Off						
Plugs Secure & Dry						Access Ladder						
						HOUSEKEEPING						
						Cleanup						
						Storage						

24 RIGGING

Tradespeople who are not professional riggers must nonetheless rig loads at times on the job. Carpenters, for instance, are often involved not only in handling but in hoisting and landing material. When in doubt about rigging, consult an experienced rigger or a professional engineer. Information in this chapter covers only the basics of rigging.

Inspection

Use this checklist to inspect rigging components regularly and before each lift.

Manila Rope	
<i>Manila rope is not recommended for construction use and is illegal for lifelines and lanyards.</i>	
Dusty residue when twisted open	Wear from inside out. Overloading. If extensive, replace rope.
Broken strands, fraying, spongy texture	Replace rope.
Wet	Strength could be reduced.
Frozen	Thaw and dry at room temperature.
Mildew, dry rot	Replace rope.
Dry and brittle	Do not oil. Wash with cold water and hang in coils to dry.

Polypropylene and Nylon Rope	
Chalky exterior appearance	Overexposed to sunlight (UV) rays. Possibly left unprotected outside. Do not use. Discard.
Dusty residue when twisted open	Worn from inside out. If extensive, replace.
Frayed exterior	Abraded by sharp edges. Strength could be reduced.
Broken strands	Destroy and discard.
Cold or frozen	Thaw, dry at room temperature before use.
Size reduction	Usually indicates overloading and excessive wear. Use caution. Reduce capacity accordingly.

Wire Rope (Figure 87)	
Rusty, lack of lubrication	Apply light, clean oil. Do not use engine oil.
Excessive outside wear	Used over rough surfaces, with misaligned or wrong sheave sizes. Reduce load capacity according to wear. If outside diameter wire is more than 1/3 worn away, the rope must be replaced.
Broken wires	Up to six allowed in one rope lay, OR three in one strand in one rope lay, with no more than one

	at an attached fitting. Otherwise, destroy and replace rope.
Crushed, jammed, or flattened strands	Replace rope.
Bulges in rope	Replace, especially non-rotating types.
Gaps between strands	Replace rope.
Core protrusion	Replace rope.
Heat damage, torch burns, or electric arc strikes	Replace rope.
Frozen rope	Do not use. Avoid sudden loading of cold rope.
Kinks, bird-caging	Replace rope. Destroy defective rope.

Polypropylene and Nylon Web Slings	
Chalky exterior appearance	Overexposed to sunlight (UV) rays. Should be checked by manufacturer.
Frayed exterior	Could have been shock-loaded or abraded. Inspect very carefully for signs of damage.
Breaks, tears, or patches	Destroy. Do not use.
Frozen	Thaw and dry at room temperature before use.
Oil-contaminated	Destroy.

Wire Rope Slings	
Broken wires	Up to six allowed in one rope lay or three in one strand in one rope lay with no more than one at an attached fitting. Otherwise, destroy and replace rope.
Kinks, bird-caging	Replace and destroy.
Crushed and jammed strands	Replace and destroy.
Core protrusion	Replace and destroy.
Bulges in rope	Replace and destroy.
Gaps between strands	Replace and destroy.
Wire rope clips	Check proper installation and tightness before each lift. Remember, wire rope stretches when loaded, which may cause clips to loosen.
Attached fittings	Check for broken wires. Replace and destroy if one or more are broken.
Frozen	Do not use. Avoid sudden loading of cold ropes to prevent failure.

Sharp bends	Avoid sharp corners. Use pads such as old carpet, rubber hose, or soft wood to prevent damage.
-------------	--

Chain Slings	
Use only alloy steel for overhead lifting.	
Elongated or stretched links	Return to manufacturer for repair.
Failure to hang straight	Return to manufacturer for repair.
Bent, twisted, or cracked links	Return to manufacturer for repair.
Gouges, chips, or scores	Ground out and reduce capacity according to amount of material removed.
Chain repairs are best left to the manufacturer. Chain beyond repair should be cut with torch into short pieces.	

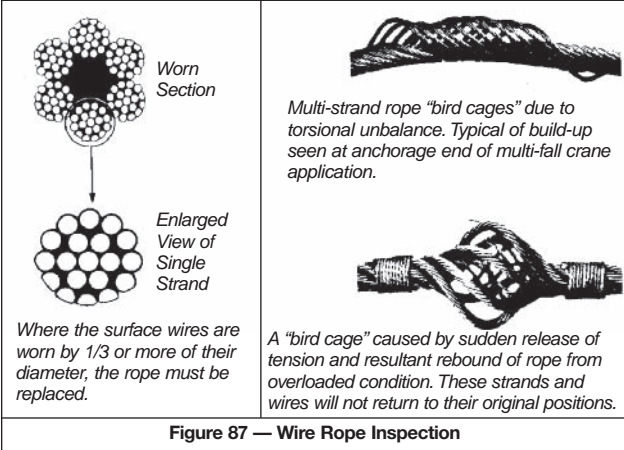
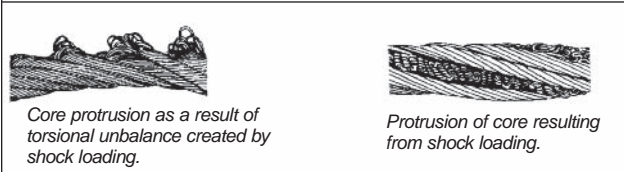
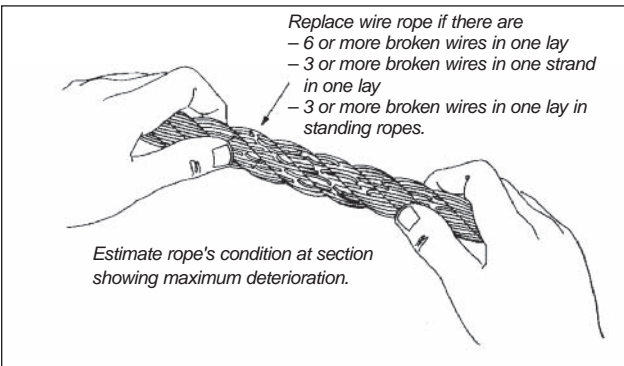


Figure 87 — Wire Rope Inspection

Hardware

Know what hardware to use, how to use it, and how its working load limits (WLLs) compare with the rope or chain used with it.

All fittings must be of adequate strength for the application. Only



Figure 88

forged alloy steel load-rated hardware should be used for overhead lifting. Load-rated hardware is stamped with its WLL (Figure 88).

Inspect hardware regularly and before each lift. Telltale signs include

- wear
- cracks
- severe corrosion
- deformation/bends
- mismatched parts
- obvious damage.

Any of these signs indicates a weakened component that should be replaced for safety. Figure 89 shows what to check for on a hook.

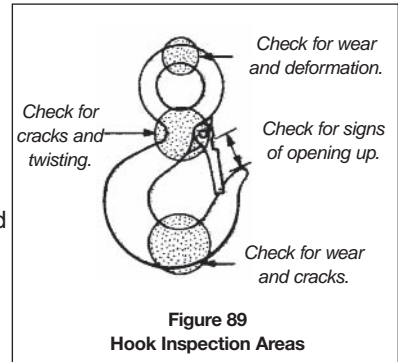


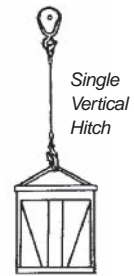
Figure 89 Hook Inspection Areas

Sling Configurations

The term “sling” includes a wide variety of configurations for all fibre ropes, wire ropes, chains, and webs. The most commonly used types in construction are explained here.

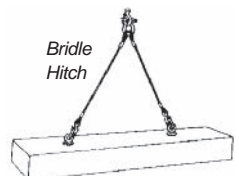
Single Vertical Hitch

The total weight of the load is carried by a single leg. This configuration must not be used for lifting loose material, long material, or anything difficult to balance. This hitch provides absolutely no control over the load because it permits rotation.



Bridle Hitch

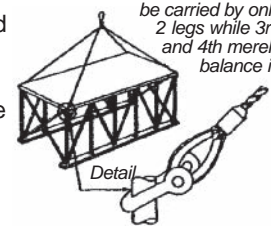
Two, three, or four single hitches can be used together to form a bridle hitch. They provide excellent stability when the load is distributed equally among the legs, when the hook is directly over the centre of gravity of the load, and the load is raised level. The leg length may need adjustment with turnbuckles to distribute the load.



Caution: Load may be carried by only 2 legs while 3rd and 4th merely balance it.

Single Basket Hitch

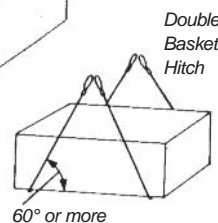
This hitch is ideal for loads with inherent stabilizing characteristics. The load is automatically equalized, with each leg supporting half the load. Do not use on loads that are difficult to balance because the load can tilt and slip out of the sling.



Single Basket Hitch

Double Basket Hitch

Consists of two single basket hitches passed under the load. The legs of the hitches must be kept far enough apart to provide balance without opening excessive sling angles.



Double Basket Hitch

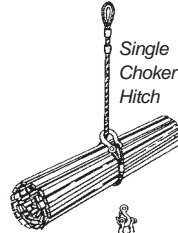
Double Wrap Basket Hitch

A basket hitch that is wrapped completely around the load. This method is excellent for handling loose materials, pipes, rods, or smooth cylindrical loads because the rope or chain exerts a full 360-degree contact with load and tends to draw it together.



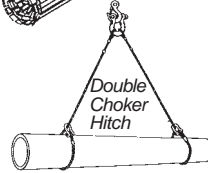
Single Choker Hitch

This forms a noose in the rope and tightens as the load is lifted. It does not provide full contact and must not be used to lift loose bundles or loads difficult to balance.



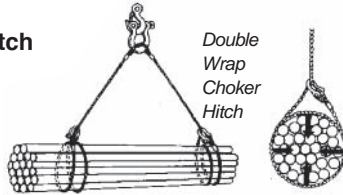
Double Choker Hitch

Consists of two single chokers attached to the load and spread to provide load stability. Does not grip the load completely but can balance the load. Can be used for handling loose bundles.



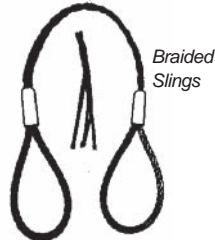
Double Wrap Choker Hitch

The rope or chain is wrapped completely around the load before being hooked into the vertical part of the sling. Makes full contact with load and tends to draw it together. If the double wrap choker is incorrectly made and the two eyes are placed on the crane hook, the supporting legs of the sling may not be equal in length and the load may be carried by one leg only. Do not run the sling through the hook, permitting an unbalanced load to tip.



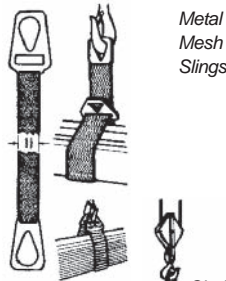
Braided Slings

Fabricated from six or eight small diameter ropes braided together to form a single rope that provides a large bearing surface, tremendous strength, and flexibility in all directions. They are very easy to handle and almost impossible to kink. Especially useful for basket hitches where low bearing pressure is desirable or where the bend is extremely sharp.



Metal (Wire or Chain) Mesh Slings

Well adapted for use where loads are abrasive, hot, or tend to cut fabric or wire rope slings.



Chain Slings

Made for abrasion and high temperature resistance. The only chain suitable for lifting is grade 80 or 100 alloy steel chain. Grade

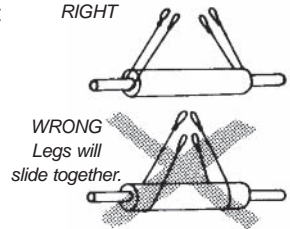


80 chain is marked with an 8, 80, or 800. Grade 100 is marked with a 10, 100, or 1000. The chain must be embossed with this grade marking every 3 feet or 20 links, whichever is shorter – although some manufacturers mark every link. Chain must be padded on sharp corners to prevent bending stresses.

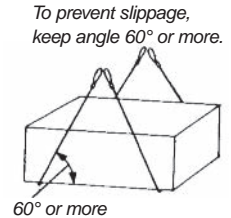
Wire Rope Slings

The use of wire rope slings for lifting materials provides several advantages over other types of slings. While not as strong as chain, it has good flexibility with minimum weight. Outer wires breaking warn of failure and allow time to react. Properly fabricated wire rope slings are very safe for general construction use.

On smooth surfaces, the basket hitch should be snubbed against a step or change of contour to prevent the rope from slipping as the load is applied. The angle between the load and the sling should be approximately 60 degrees or greater to avoid slippage.



On wooden boxes or crates, the rope will dig into the wood sufficiently to prevent slippage. On other rectangular loads, the rope should be protected by guards or load protectors at the edges to prevent kinking.








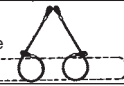
Loads should not be allowed to turn or slide along the rope during a lift. The sling or the load may become scuffed or damaged. Use a double choker if the load must turn.

Hooking Up

- Avoid sharp bends, pinching, and kinks in rigging equipment. Thimbles should be used at all times in sling eyes.
- Never wrap a wire rope sling completely around a hook. The tight radius will damage the sling.
- Make sure the load is balanced in the hook. Eccentric loading can reduce capacity dangerously.
- Never point-load a hook unless it is designed and rated for such use (Figure 91).
- Never wrap the crane hoist rope around the load. Attach the load to the hook by slings or other rigging devices adequate for the load.
- Avoid bending the eye section of wire rope slings around corners. The bend will weaken the splice or swaging.
- Avoid bending wire rope slings near any attached fitting.
- Understand the effect of sling angle on sling load (Figure 92) and pull angle on beam load (Figure 93).

Rig the load with its centre of gravity directly below the hook to ensure stability. The crane hook should be brought over the load's centre of gravity before the lift is started. Crane hook and load line should be vertical before lifting. Weights of common materials are listed in Tables 7 to 11.

WIRE ROPE SLINGS						
6 x 19 Classification Group, Improved Plow Steel, Fibre Core						
MAXIMUM WORKING LOAD LIMITS - POUNDS (Design Factor = 5)						
Rope Diameter (Inches)	Single Vertical Hitch	Single Choker Hitch	Single Basket Hitch (Vertical Legs)	2-Leg Bridle Hitch & Single Basket Hitch With Legs Inclined		
						
				60°	45°	30°
3/16	600	450	1,200	1,050	850	600
1/4	1,100	825	2,200	1,900	1,550	1,100
5/16	1,650	1,250	3,300	2,850	2,350	1,650
3/8	2,400	1,800	4,800	4,150	3,400	2,400
7/16	3,200	2,400	6,400	5,550	4,500	3,200
1/2	4,400	3,300	8,800	7,600	6,200	4,400
9/16	5,300	4,000	10,600	9,200	7,500	5,300
5/8	6,600	4,950	13,200	11,400	9,350	6,600
3/4	9,500	7,100	19,000	16,500	13,400	9,500
7/8	12,800	9,600	25,600	22,200	18,100	12,800
1	16,700	12,500	33,400	28,900	23,600	16,700
1-1/8	21,200	15,900	42,400	36,700	30,000	21,200
1-1/4	26,200	19,700	52,400	45,400	37,000	26,200
1-3/8	32,400	24,300	64,800	56,100	45,800	32,400
1-1/2	38,400	28,800	76,800	66,500	54,300	38,400
1-5/8	45,200	33,900	90,400	78,300	63,900	45,200
1-3/4	52,000	39,000	104,000	90,000	73,500	52,000
1-7/8	60,800	45,600	121,600	105,300	86,000	60,800
2	67,600	50,700	135,200	117,100	95,600	67,600
2-1/4	84,000	63,000	168,000	145,500	118,800	84,000
2-1/2	104,000	78,000	208,000	180,100	147,000	104,000
2-3/4	122,000	91,500	244,000	211,300	172,500	122,000

If used with Choker Hitch multiply above values by 3/4. 

Notes: Table values are for slings with eyes and thimbles in both ends, Flemish Spliced Eyes and mechanical sleeves. Eyes formed by cable clips – reduce loads by 20%.

Caution: This table contains sample values for the purposes of illustration only. Refer to the manufacturer of the equipment you're using for precise values.

Figure 91
Point Loading



Capacity Severely Reduced

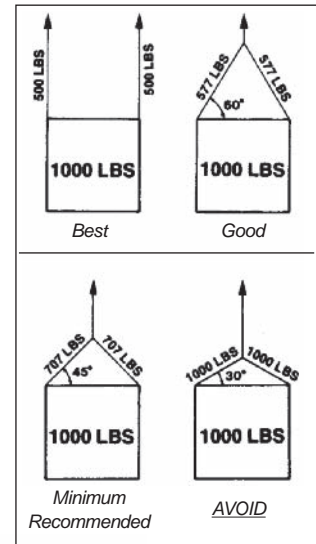


Figure 92
Effect of Sling Angle on Sling Load

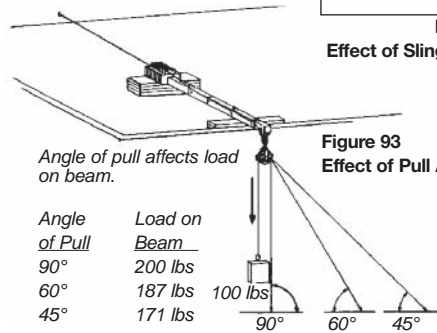
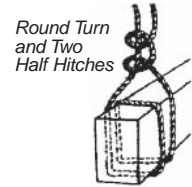


Figure 93
Effect of Pull Angle on Beam Load

Basic Knots and Hitches

Every worker should be able to tie the basic knots and hitches that are useful in everyday work.

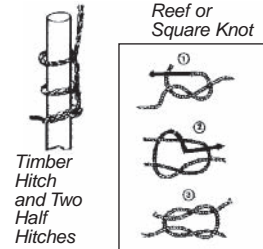


Round Turn and Two Half Hitches

Used to secure loads to be hoisted horizontally. Two are usually required because the load can slide out if lifted vertically.

Timber Hitch and Two Half Hitches

A good way to secure a scaffold plank for hoisting vertically. The timber hitch grips the load.



Reef or Square Knot

Can be used for tying two ropes of the same diameter together. It is unsuitable for wet or slippery ropes and should be used with caution since it unties easily when either free end is jerked. Both live and dead ends of the rope must come out of the loops at the same side.

Two Half Hitches

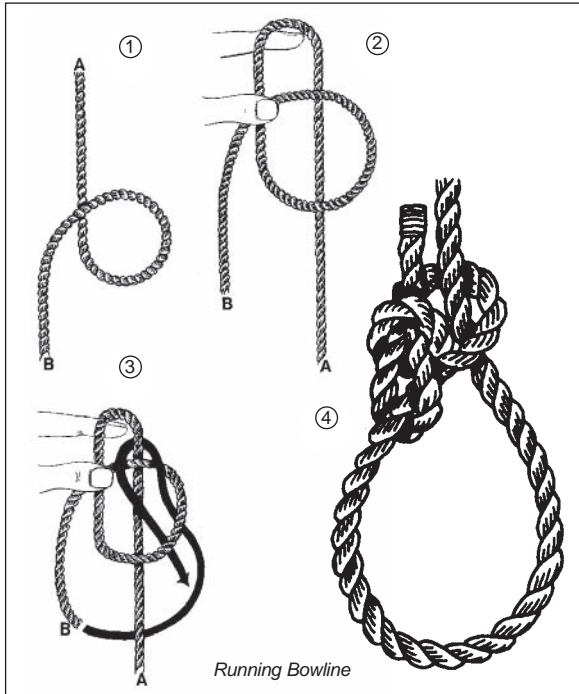
Two half hitches, which can be quickly tied, are reliable and can be put to almost any general use.



Running Bowline

The running bowline is mainly used for hanging objects with ropes of different diameters. The weight of the object determines the tension necessary for the knot to grip.

Make an overhand loop with the end of the rope held toward you (1). Hold the loop with your thumb and fingers and bring the standing part of the rope back so that it lies behind the loop (2). Take the end of the rope in behind the standing part, bring it up, and feed it through the loop (3). Pass it behind the standing part at the top of the loop and bring it back down through the loop (4).

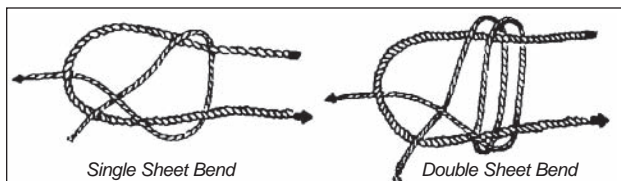
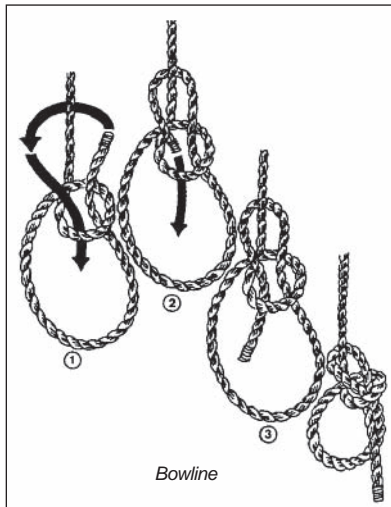


Bowline

Never jams or slips when properly tied. It is a universal knot if properly tied and untied. Two interlocking bowlines can be used to join two ropes together. Single bowlines can be used for hoisting or hitching directly around a ring or post.

Sheet Bend

Can be used for tying ropes of light or medium size.



WEIGHTS OF MATERIALS (Based On Volume)			
Material	Approximate Weight Lbs. Per Cubic Foot	Material	Approximate Weight Lbs. Per Cubic Foot
METALS		TIMBER, AIR-DRY	
Aluminum	165	Cedar	22
Brass	535	Fir, Douglas, seasoned	34
Bronze	500	Fir, Douglas, seasoned	40
Copper	560	Fir, Douglas, wet	50
Iron	480	Fir, Douglas, glue laminated	34
Lead	710	Hemlock	30
Steel	480	Pine	30
Tin	460	Poplar	30
MASONRY		Spruce	
Ashlar masonry	140-160	LIQUIDS	
Brick masonry, soft	110	Alcohol, pure	49
Brick masonry, common (about 3 tons per thousand)	125	Gasoline	42
Brick masonry, pressed	140	Oils	58
Clay tile masonry, average	60	Water	62
Rubble masonry	130-155	EARTH	
Concrete, cinder, taydite	100-110	Earth, wet	100
Concrete, slag	130	Earth, dry (about 2050 lbs. per cu. yd.)	75
Concrete, stone	144	Sand and gravel, wet	120
Concrete, stone, reinforced (4050 lbs. per cu. yd.)	150	Sand and gravel, dry	105
ICE AND SNOW		River sand (about 3240 lbs. per cu. yd.)	
Ice	56	VARIOUS BUILDING MATERIALS	
Snow, dry, fresh fallen	8	Cement, portland, loose	94
Snow, dry, packed	12-25	Cement, portland, set	183
Snow, wet	27-40	Lime, gypsum, loose	53-64
MISCELLANEOUS		Mortar, cement-time, set	103
Asphalt	80	Crushed rock (about 2565 lbs. per cu. yd.)	90-110
Tar	75		
Glass	160		

Table 7

Caution: This table contains sample values for the purposes of illustration only. Refer to the manufacturer of the material you're using for precise values.

DRYWALL WEIGHTS

	8'	10'	12'
Non-Fire Rated			
1/2"	58 lbs.	72 lbs.	86 lbs.
5/8"	74 lbs.	92 lbs.	110 lbs.
Fire-Rated			
1/2"	64 lbs.	80 lbs.	96 lbs.
5/8"	77 lbs.	96 lbs.	115 lbs.

Table 8

Caution: This table contains sample values for the purposes of illustration only. Refer to the manufacturer of the material you're using for precise values.

STEEL STUDS AND TRIMS - WEIGHTS

STUD SIZE--.018 THICKNESS	Pcs./Bdl.	Lbs. (per 1,000 Lin. Ft.)
1 5/8 All Lengths	10	290
2 1/2 All Lengths	10	340
3 5/8 All Lengths	10	415
6 (.020) All Lengths	10	625
TRACK SIZES--.018 THICKNESS		
1 5/8 Regular Leg	10	240
2 1/2 Regular Leg	10	295
3 5/8 Regular Leg	10	365
6 (.020) Regular Leg	10	570
1 5/8 2 Leg	12	365
2 1/2 2 Leg	6	415
3 5/8 2 Leg	6	470
DRYWALL FURRING CHANNEL		
Electro-Galvanized	10	300
DRYWALL CORNER BEAD		
1 1/4 x 1 1/4	Various	120
RESILIENT CHANNEL		
Electro-Galvanized	20	210
DRYWALL TRIMS		
1/2 Door & Windows L.	20	100
5/8 Door & Window L.	20	100
3/8 Casing Bead J.	20	110
1/2 Casing Bead J.	20	120
5/8 Casing Bead J.	20	130
DRYWALL ANGLE		
1 x 2 Drywall Angle	10	200

Table 9

Caution: This table contains sample values for the purposes of illustration only. Refer to the manufacturer of the material or equipment you're using for precise values.

WEIGHTS OF MATERIALS (Based On Surface Area)

Material	Approximate Weight Lbs. Per Square Foot	Material	Approximate Weight Lbs. Per Square Foot
CEILING (Per Inch of Thickness)		FLOORING (Per Inch of Thickness)	
Plaster board	5	Hardwood	5
Acoustic and fire resistive tile	2	Sheathing	2.5
Plaster, gypsum-sand	8	Plywood, fir	3
Plaster, light aggregate	4	Wood block, treated	4
Plaster, cement sand	12	Concrete, finish or fill	12
ROOFING		DECKS AND SLABS	
Three-ply felt and gravel	5.5	Mastic base	12
Five-ply felt and gravel	6.5	Mortar base	10
Three-ply felt, no gravel	3	Terrazzo	12.5
Five-ply felt, no gravel	4	Tile, vinyl 1/8 inch	1.5
Shingles, wood	2	Tile, linoleum 3/16 inch	1
Shingles, asbestos	3	Tile, cork, per 1/16 inch	0.5
Shingles, asphalt	2.5	Tile, rubber or asphalt 3/16 inch	2
Shingles, 1/4 inch slate	10	Tile, ceramic or quarry 3/4 inch	11
Shingles, tile	14	Carpeting	2
PARTITIONS		MISCELLANEOUS	
Steel partitions	4	Windows, glass, frame	8
Solid 2" gypsum-sand plaster	20	Skylight, glass, frame	12
Solid 2" gypsum-light agg. plaster	12	Corrugated asbestos 1/4 inch	3.5
Metal studs, metal lath, 3/4" plaster both sides	18	Glass, plate 1/4 inch	3.5
Metal or wood studs, plaster board and 1/2" plaster both sides	18	Glass, common	1.5
Plaster 1/2"	4	Plastic sheet 1/4 inch	1.5
Hollow clay tile 2 inch	13	Corrugated steel sheet, galv.	5.5
3 inch	16	- 12 ga.	5
4 inch	18	- 14 ga.	4
5 inch	20	- 16 ga.	3
6 inch	25	- 18 ga.	2.5
6 inch	24	- 20 ga.	2
Hollow slag concrete block 4 in 6 in	35	- 22 ga.	1.5
Hollow gypsum block 3 inch	10	Concrete, reinforced, per inch	12.5
4 inch	13	Concrete, gypsum, per inch	5
5 inch	15.5	Concrete, lightweight, per inch	5-10
6 inch	16.5	MISCELLANEOUS	
Solid gypsum block 2 inch	9.5	Windows, glass, frame	8
3 inch	13	Skylight, glass, frame	12
MASONRY WALLS (Per 4 Inch of Thickness)		Corrugated asbestos 1/4 inch	3.5
Brick	40	Glass, plate 1/4 inch	3.5
Glass brick	20	Glass, common	1.5
Hollow concrete block	30	Plastic sheet 1/4 inch	1.5
Hollow slag concrete block	24	Corrugated steel sheet, galv.	5.5
Hollow cinder concrete block	20	- 12 ga.	5
Hollow haydite block	22	- 14 ga.	4
Stone, average	55	- 16 ga.	3
Bearing hollow clay tile	23	- 18 ga.	2.5
		- 20 ga.	2
		- 22 ga.	1.5
		Wood Joists - 16" ctrs. 2 x 12	3.5
		2 x 10	3
		2 x 8	2.5
		Steel plate (per inch of thickness)	40

Table 10

Caution: This table contains sample values for the purposes of illustration only. Refer to the manufacturer of the material you're using for precise values.



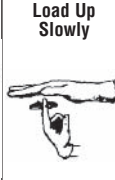
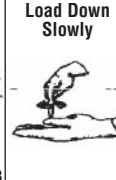




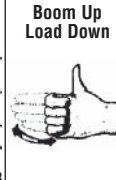
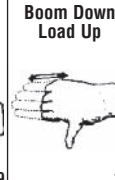

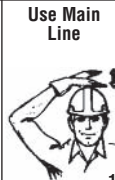




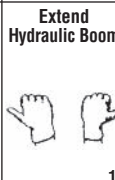
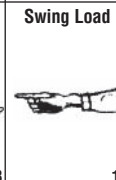
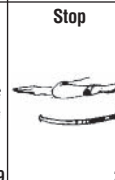



SUSPENDED CEILING GRID SYSTEMS-WEIGHTS

Systems	Qty./Ctn. (Lin. Ft.)	Lbs./Ctn. (Lbs.)
NON-FIRE RATED GRID SYSTEM		
1 1/2 x 144" Main Runner	240	58
1 x 48" Cross Tee	300	55
1 x 24" Cross Tee	150	28
1 x 30" Cross Tee	187.5	35
1 x 20" Cross Tee	125	23
1 x 12" Cross Tee	75	14
FIRE-RATED GRID SYSTEM		
1 1/2 x 144" Main Runner	240	70
1 1/2 x 48" Cross Tee	240	70
1 1/2" x 24" Cross Tee	120	35
WALL MOULDINGS		
Wall Mould 3/4 x 15/16 x 120"	400	49
Reveal Mould 3/4 x 3/4 x 1/2 x 3/4 x 120"	200	36
ACCESSORIES		
Hold-Down Clips (for 5/8" tile)	500 pcs.	3
BASKETWEAVE & CONVENTIONAL		
5' x 5' MODULE - NON RATED		
1 1/2 x 120" Main Member	200	49
1 1/2 x 60" Cross Tee	250	61
Wall Mould 3/4 x 15/16 x 120"	400	57
THIN LINE GRID SYSTEM - NON-RATED		
Main Runner 1 1/2 x 144"	300	65
Cross Tee 1 1/2 x 48"	300	65
Cross Tee 1 1/2 x 24"	150	33
Wall Mould 15/16 x 9/16 x 120"	500	62
Reveal Mould 1 x 3/8 x 3/8 x 9/16 x 120"	300	48
Main Runner 1 1/12 x 144"	300	65
Cross Tee 1 1/2 x 48"	300	65
Cross Tee 1 1/2 x 24"	150	33
Wall Mount 15/16 x 9/16 x 120"	500	62

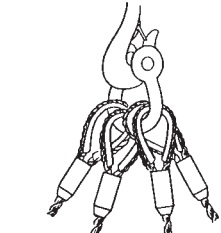
Table 11

Caution: This table contains sample values for the purposes of illustration only. Refer to the manufacturer of the material or equipment you're using for precise values.

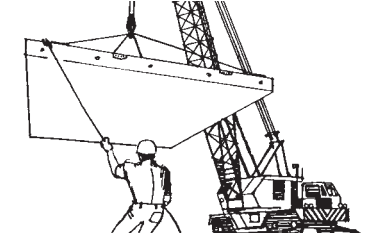
HAND SIGNALS FOR HOISTING OPERATIONS

Load Up  1	Load Down  2	Load Up Slowly  3	Load Down Slowly  4	Boom Up  5
Boom Down  6	Boom Up Slowly  7	Boom Down Slowly  8	Boom Up Load Down  9	Boom Down Load Up  10
Everything Slowly  11	Use Whip Line  12	Use Main Line  13	Travel Forward  14	Turn Right  15
Turn Left  16	Shorten Hydraulic Boom  17	Extend Hydraulic Boom  18	Swing Load  19	Stop  20
Close Clam  21	Open Clam  22	Dog Everything  23	No response should be made to unclear signals.	

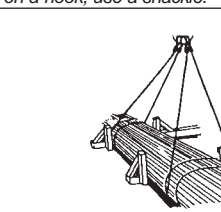
Rigging Safety Tips



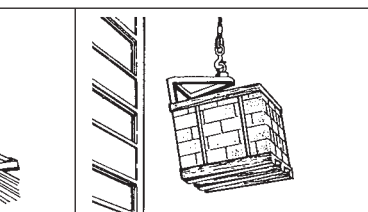
With two or more slings on a hook, use a shackle.



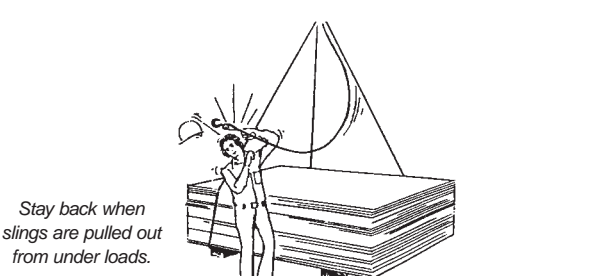
Use tag lines for control.



Block loose loads before unhooking.



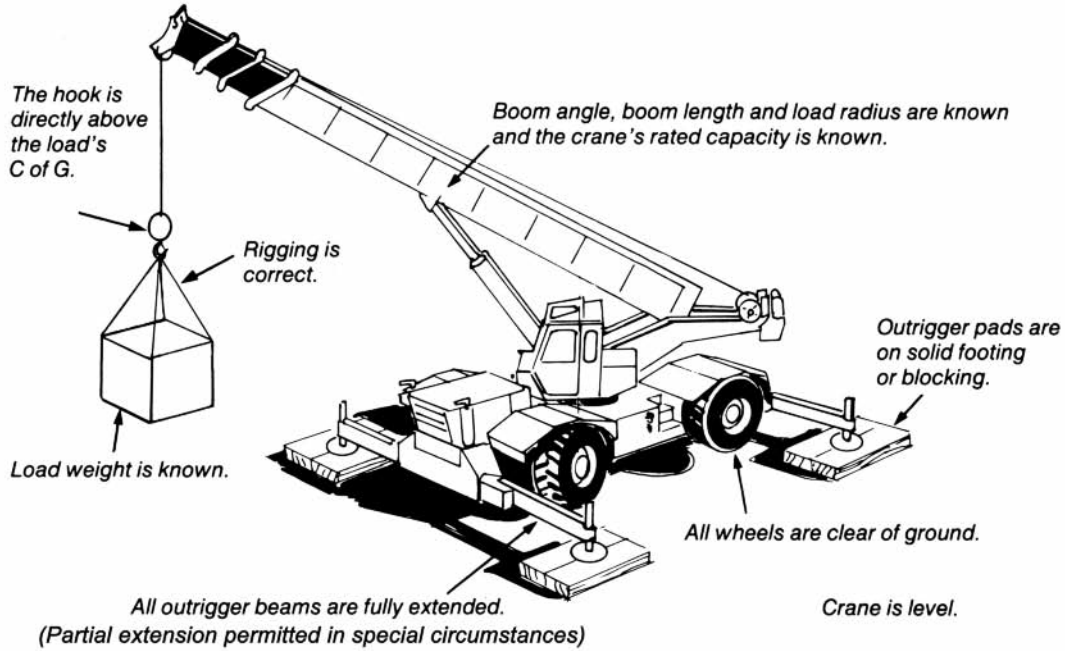
Make sure loads are secure.



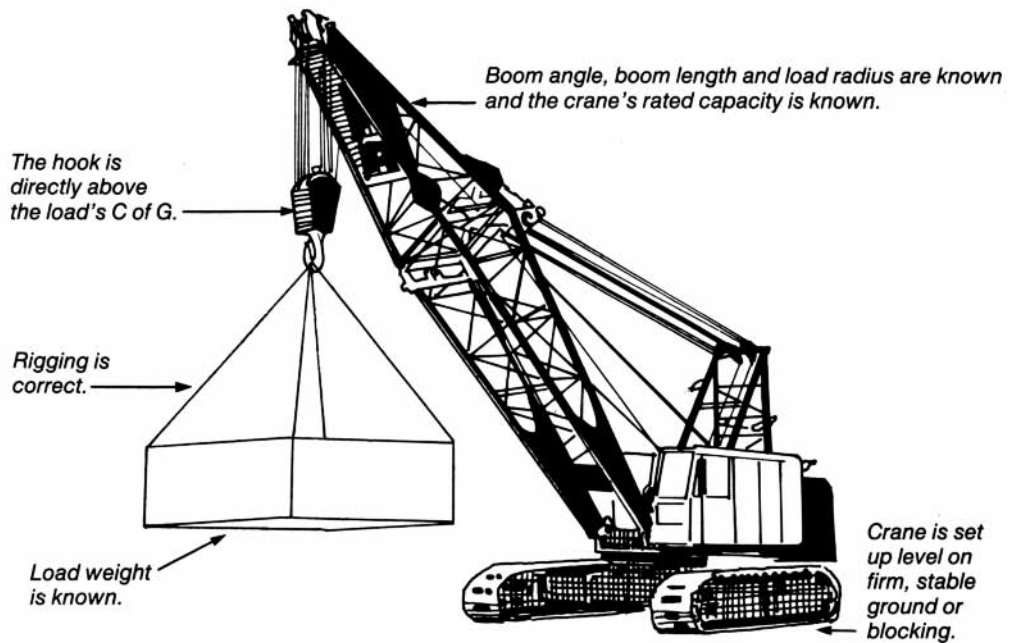
Stay back when slings are pulled out from under loads.

A crane is properly set up for lifting when the following conditions are met.

For Cranes Operating “On Outriggers”



For Crawler-Mounted Cranes or When Lifting “On Rubber”



Hazards

25 HOUSEKEEPING AND FIRE SAFETY

Many injuries result from poor housekeeping, improper storage of materials, and cluttered work areas. To maintain a clean, hazard-free workplace, all groups – management, supervision, and workers – must cooperate.

General

Regulations for safe housekeeping require

- daily jobsite cleanup program
- disposal of rubbish
- individual cleanup duties for all workers
- materials piled, stacked, or otherwise stored to prevent tipping and collapsing
- materials stored away from overhead powerlines
- work and travel areas kept tidy, well-lit, and ventilated (Figure 8)
- signs posted to warn workers of hazardous areas.

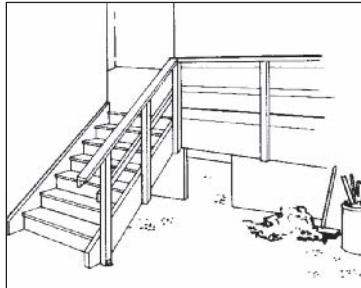


Figure 8
Keep stairs and landings clear and well-lit.

The basics of good housekeeping are shown in Figure 9.

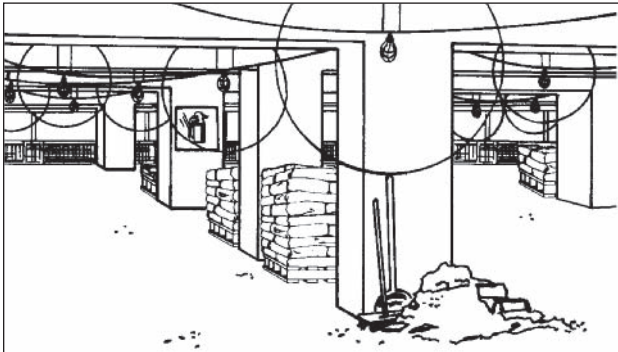


Figure 9

Good housekeeping means clear traffic and work areas, out-of-the-way storage, adequate illumination, and cleanup of debris.

Specific

- Gather up and remove debris as often as required to keep work and travel areas orderly.
- Keep equipment and the areas around equipment clear of scrap and waste.
- Keep stairways, passageways, and gangways free of material, supplies, and obstructions at all times.
- Secure loose or light materials stored on roof or on open floors to prevent them being blown by the wind.
- Pick up, store, or dispose of tools, material, or debris which may cause tripping or other hazards.
- Before handling used lumber, remove or bend over protruding nails and chip away hardened concrete.
- Wear eye protection when there is any risk of eye injury.
- Do not permit rubbish to fall freely from any level of the project. Lower it by means of a chute or other approved devices (Figure 10).
- Do not throw materials or tools from one level to another.
- Do not lower or raise any tool or equipment by its own cord or supply hose.

- When guardrails must be removed to land, unload, or handle material, wear fall-arrest equipment (Figure 11). The area must also be roped off with warning signs posted.

In shops it is relatively easy to maintain a clean work area. Barriers and warning lines can also be set up to isolate table saws and other equipment.

On construction sites, arrangements are more difficult. Equipment often sits in basements, on decks, or in corners with insufficient working space and sometimes it's open to the weather. The footing may simply consist of a piece of plywood.

Around table saws and similar equipment, keep the immediate area clear of scrap to avoid tripping hazards and provide sound footing.

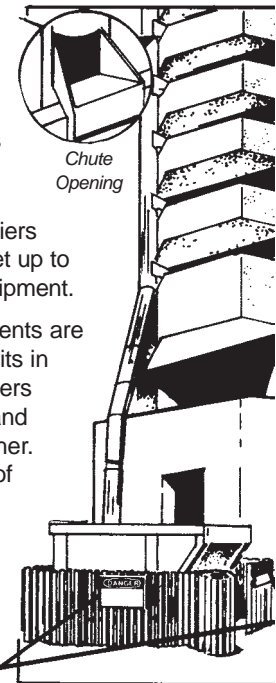


Figure 10

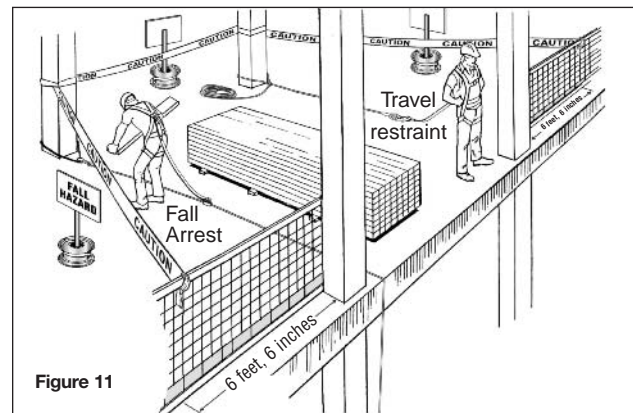


Figure 11

Airborne wood dust can be a respiratory hazard, causing problems ranging from simple irritation of the eyes, nose, and throat to more serious health effects. Dust collectors should be installed in shops to remove sawdust from air and equipment. Wood dust is also very flammable.

In construction, saws and other tools are often operated in the open air where dust presents no hazard. However, dust masks or respirators should be worn whenever ventilation is inadequate.

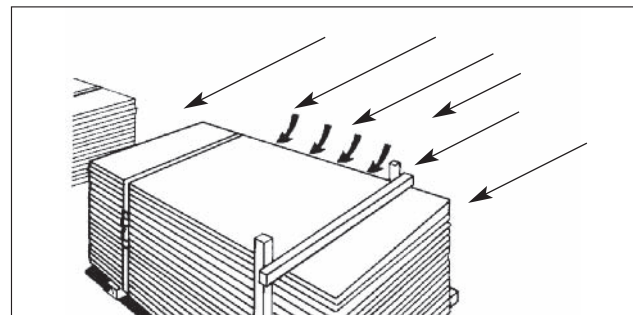


Figure 12
Secure material against the wind. After removing material, resecure pile.

Storage

Storage areas should be at least 1.8 metres (6 feet) from roof or floor openings, excavations, or any open edges where material may fall off (Figure 12).

Near openings, arrange material so that it cannot roll or slide in the direction of the opening.

Flammable Materials

- Use copper grounding straps to keep static electricity from building up in containers, racks, flooring, and other surfaces (Figure 13).
- Store fuel only in containers approved by the Canadian Standards Association (CSA) or Underwriters' Laboratories of Canada (ULC).
- Ensure that electric fixtures and switches are explosion-proof where flammable materials are stored.
- See Figure 14 for pointers on safe storage.

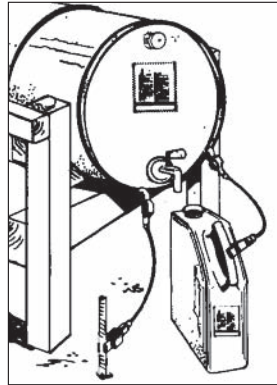


Figure 13
Dispensing and receiving containers should both be grounded.

Hazardous Chemicals

- Refer to material safety data sheets (MSDSs) for specific information on each product.
- Follow manufacturer's recommendations for storage.
- Observe all restrictions concerning heat, moisture, vibration, impact, sparks, and safe working distance.
- Post warning signs where required.
- Have equipment ready to clean up spills quickly.

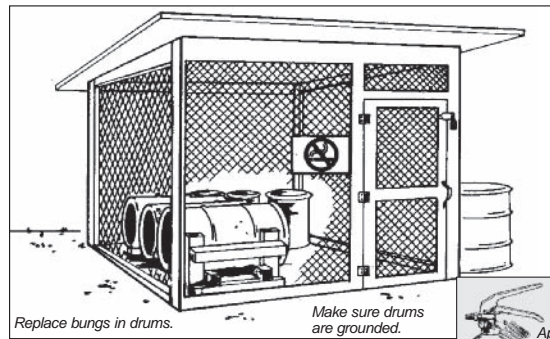
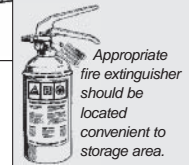


Figure 14
Storage of Flammable Liquids



- To keep them separate for special handling and disposal later, store empty chemical containers in secure area away from full containers.

Bags and Sacks

- Do not pile bagged material more than 10 bags high unless the face of the pile is supported by the walls of a storage bin or enclosure.
- Do not move piles more than 10 bags high unless fully banded or wrapped.
- Cross-pile bags and sacks for added stability. Pile only to a safe and convenient height for loading and unloading.

Compressed Gas Cylinders

- Store and move cylinders in the upright position. Secure cylinders upright with chains or rope.
- Lock up cylinders to prevent vandalism and theft.
- Wherever possible, store cylinders in a secure area outdoors.



Class "A" Extinguishers

For fires in ordinary combustible materials such as wood, paper, and textiles where a quenching, cooling effect is required.



Class "B" Extinguishers

For flammable liquid and gas fires, such as oil, gasoline, paint and grease where oxygen exclusion or flame interruption is essential.



Class "C" Extinguishers

For fires involving electrical wiring and equipment where the non-conductivity of the extinguishing agent is crucial.

This type of extinguisher should be present wherever functional testing and system energizing take place.



Class "D" Extinguishers

For fires in combustible metals such as sodium, magnesium, and potassium.

How to Use the Extinguisher

Aim the extinguisher at the base of the fire to extinguish the flames at their source.

Figure 15

- Keep full cylinders apart from empty cylinders.
- Store cylinders of different gases separately.
- Keep cylinders away from heat sources.
- When heating with propane, keep 45-kilogram (100 lb.) cylinders at least 3 metres (10 feet) away from heaters; keep larger tanks at least 7.6 metres (25 feet) away.

Lumber

- Stack on level sills.
- Stack reusable lumber according to size and length. Remove nails during stacking.
- Support lumber at every 1.2-metre (4-foot) span.
- Cross-pile or cross-strip when the pile will be more than 1.2 metres (4 feet) high.

Fire Protection

Housekeeping includes fire prevention and fire protection. Workers must be trained to use fire extinguishers properly.

Fire extinguishers must be

- accessible
- regularly inspected
- promptly refilled after use.

Extinguishers must be provided

- where flammable materials are stored, handled, or used
- where temporary oil- or gas-fired equipment is being used
- where welding or open-flame cutting is being done
- on each storey of an enclosed building being constructed or renovated
- in workshops, for at least every 300 square metres of floor area.

Fire extinguishers are classified according to their capacity to fight specific types of fires (Figure 15).

Workers must be trained to use fire extinguishers properly.

For most operations, a 4A40BC extinguisher is adequate.

Extinguishers have a very short duration of discharge – usually less than 60 seconds. Be sure to aim at the base of the fire.

26 ELECTRICAL HAZARDS

CONTENTS

- Introduction
- Electrical injuries
- Safeguards
- Working on energized systems
- Portable tools and extension cords
- Temporary wiring and power
- Other electrical issues
- Reporting electrical accidents/incidents

INTRODUCTION

An **electrical hazard** can be defined as

- a dangerous condition where a worker could make electrical contact with energized equipment or a conductor, and from which the person may sustain an injury from shock; and/or,
- there is potential for the worker to receive an arc flash burn, thermal burn, or blast injury.

Note: An electric hazard is considered to be removed when protective measures are put in place at the source (remove hazard or de-energize), or along the path (place electrical insulation/barrier between the worker and the electrical hazard). Where PPE is relied upon for worker protection, an electrical hazard is considered to remain and it is still necessary to address safety requirements for other workers in the area.

Injuries resulting from a worker making electrical contact represent a relatively small portion (7.7%) of the lost-time injuries electricians experience, according to 1997–1999 statistics. It is reasonable to assume that the situation is similar today. Other mechanical trades that do some electrical work can probably expect even fewer electrical injuries.

Nevertheless, working on or near electrical hazards is dangerous and can be fatal. Any work on or near energized equipment must be done only when measures are in place to provide protection from electric shock and burn. With adequate safety measures in place, every electrical injury and fatality can be prevented.

The law requires safe work practices. Under the *Occupational Health and Safety Act and Regulations for Construction Projects*, employers, supervisors, and workers each have legal responsibilities to ensure that work is being carried out in a safe manner.

There are also restrictions in the Construction Regulation (Ontario Regulation 213/91 Section 182) on who can work on electrical equipment:

- (1) *No worker shall connect, maintain, or modify electrical equipment or installations unless,*
 - (a) *the worker is an electrician certified under the Trades Qualification and Apprenticeship Act; or*
 - (b) *the worker is otherwise permitted to connect, maintain or modify electrical equipment or installations under the Trades Qualification and Apprenticeship Act, the Apprenticeship and Certification Act, 1998 or the Technical Standards and Safety Act, 2000.*
- (2) *A worker who does not meet the requirements of clause (1) (a) or (b) may insert an attachment plug cap on the cord of electrical equipment or an electrical tool into, or remove it from, a convenience receptacle.*

Guidelines for working on or near electrical equipment and conductors are found in several documents:

- Construction Regulation (O. Reg. 213/91)
- *Ontario Electrical Safety Code*

- Operating manuals for different tools and equipment.
- NFPA 70E *Standard for Electrical Safety in the Workplace*
- CSA Z462 *Workplace Electrical Safety**.
 - * CSA Z462, tentatively called *Workplace Electrical Safety*, is under development. It is a Canadian version of the US electrical safety standard NFPA 70E *Standard for Electrical Safety in the Workplace* and is anticipated to be available in 2008.

An important aspect of electrical work involves isolating electrical energy. A reference for detailed information on lockout and control of hazardous energy is the Canadian standard CSA Z460-05, *Control of Hazardous Energy—Lockout and Other Methods*.

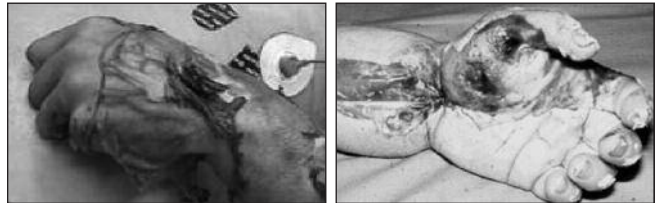
ELECTRICAL INJURIES

There are basically two ways to be injured by electricity. One is by electric shock and the other is by arc flash.

Electric shock is the passing of electric current through the body. Electrical contact can cause involuntary physical movements. The electrical current may

- prevent you from releasing your grip from a live conductor
- throw you into contact with a higher voltage conductor
- cause you to lose your balance and fall
- cause severe internal and external burns
- kill you.

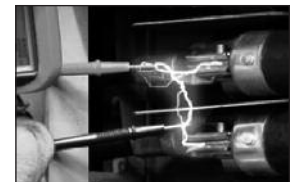
A household 125-volt circuit can deliver 15 amps. Current as low as 30/1000 of 1 amp (30 mA) can cause breathing to stop. A 15-Amp circuit contains many times the current needed to cause death.



A major cause of accidents involving electricity comes from the failure to identify the hazards associated with live electrical equipment and wiring.



An **arc flash** is a release of energy caused by an electric arc. The flash causes an explosive expansion of air and metal. The blast produces



Electric arc

- a dangerous pressure wave
- a dangerous sound wave
- shrapnel
- extreme heat
- extreme light.



These dangers can result in blast injuries, lung injuries, ruptured eardrums, shrapnel wounds, severe burns, and blindness. Arc flash injuries can also result in death.



Arc flash

SAFEGUARDS

Protective tools and equipment

Workers exposed to an electrical hazard must use mats, gloves, shields, flame resistant clothing, and any other protective equipment required to protect themselves from electric shock and burn. As part of everyday work, electrical workers should always

- remove watches, rings, neck chains, or other current-conducting apparel
- wear electric-shock-resistant footwear
- wear a CSA-approved Class E hard hat or equivalent
- wear safety glasses with side shields, and
- wear under and outer clothing that has flame-resistance properties.

Tools, devices, and equipment — including personal protective equipment — used for live work must be designed, tested, maintained, and used so as to provide adequate protection for workers.

Where there is the potential for an arc flash, **all** PPE should be chosen with consideration for the kinds of hazards that can result from an arc flash. See Flash Hazard (Arc Flash) Protection below.

The following information provides guidelines on appropriate and required personal protective equipment. Check the reference documents identified at the beginning of this chapter to determine your job-specific needs. See also the chapters on personal protective equipment in this manual. As well, see the chapters on personal protective equipment in the Equipment section of this manual.

Clothing

Whether or not the day's planned work involves working near an electrical hazard, workers that do electrical work should choose everyday clothing that offers some flame resistance properties. When work must be done in the

presence of an electrical hazard, ensure that all clothing is chosen to provide adequate protection from the potential hazards. See Flash Hazard (Arc Flash) Protection below.

Head protection

The following hard hats comply with the Construction Regulation:

- CSA Z94.1-1992 Class E (Canadian)
- ANSI Z89.1-1997 Type II Class E (US)
- ANSI Z89.1-1997 Type I Class E. (US)

Note that under the latest ANSI standard, there are two types of Class E hard hats: Type I and Type II. Type I hats are similar to the old CSA Class B hard hats which provide limited lateral impact protection. The Type II hats have enhanced lateral protection like the CSA Class E. ANSI Type II Class E hard hats are clearly labelled "Type II." If your hard hat just says "ANSI Class E," assume it's a Type I.

Foot protection

Construction workers require Grade 1 toe protection with sole protection in accordance with the Canadian Standards Association standard (CSA) Z195-02. Protective footwear compliant with the intent of the Construction Regulation is identified by a green triangular patch on the tongue or the ankle of the footwear.

Mechanical trades people exposed to electrical hazards should also wear electric-shock-resistant footwear identified by a white rectangular label bearing the CSA logo and the Greek letter omega in orange.



CSA logo



omega

Eye protection

The Canadian Standards Association (CSA) standard CAN/CSA Z94.3-99 *Industrial Eye and*

Face Protectors can assist you in classifying hazards and recommending protectors. Appropriate protection chosen according to this standard meets with the intent of the Construction Regulation regarding eye protection worn on the job.

In any case, eye protection should be of industrial quality eye protection in the form of safety glasses incorporating side-shields or a wrap-around style. Arc flash protection requires a face shield that is rated for arc flash, with safety glasses underneath.

Regular plastic face shields do not to provide arc flash protection. They can burn and melt in an arc flash incident. Use a face shield that is designed and rated for arc flash protection.

Hearing protection

Hearing protection is important at work since continuous exposure to excessive noise can lead to hearing loss and tinnitus. Hearing protection is required for some arc flash hazards. Hearing protection is available in three general types:

1. Disposable ear plugs made of pliable material. One size fits all, but they should only be used once.
2. Reusable custom-fit ear plugs are available to provide protection for specific frequencies of noise. These provide a good seal and can be washed and reused.
3. Earmuffs. They need to be fitted to provide maximum protection.

Shock protection

The passage of electricity through the body is called shock. Effects can range from a tingling sensation to death. A shock that may not be enough to cause injury can nonetheless startle a worker, causing an involuntary reaction that can result in serious injuries or death.

A household 125-volt circuit can deliver 15 amps. Current as low as 30/1000 of 1 amp (30

mA) can cause breathing to stop. A 15-amp circuit has many times the current needed to cause death.

Rubber gloves and leather protectors are the most common personal protective equipment used for shock protection. These must be adequate to protect the worker from electrical shock or burn. The rubber gloves must have been tested and certified.

Class 0 and Class 00 gloves must be air-tested and visually inspected for damage and adequacy immediately before each use. *Class 0 and Class 00 are exempt from regular re-certification unless work is carried out under the Electrical Utility Safety Rules.* Rubber gloves rated for use with voltages above 5,000 volts AC must be regularly tested and certified to ensure that they can withstand the voltages for which they are rated,

- at least once every three months if they are in service, or
- once every six months, if they are not in service.

Workers must be trained in the proper use, care, and storage of rubber gloves and leather protectors.

Rubber mats and shields can also be used with standard personal protective equipment to protect the worker from electric shock or burn. The rubber mat must have been tested and certified.

The best shock protection is afforded by turning off or isolating the electrical power from the worker. The Construction Regulation requires all work to be done with the system de-energized unless certain specified conditions are met. See “Working on Energized Systems” in this chapter.

Flash hazard (arc flash) protection

A **flash hazard** is defined as a dangerous condition associated with the release of energy caused by an electric arc (NFPA 70E 2004). The release of energy is often referred to as an arc flash.

An arc flash produces thermal energy which is measured in calories/cm². Adhering to arc flash protection calculations can still expose a worker to second degree burns, or 1.2 calories/cm².

One calorie is the amount of heat needed to raise the temperature of one gram of water by 1°C.

Second degree burn results from exposure to 1.2 cal/cm² for more than 0.1 second.

1.2 calories/cm² is equivalent to holding your finger in the blue part of a butane lighter flame for one second.

These conditions can lead to arc flash:

- accidental contact between two conductors
- wiring errors
- insulation deterioration or failure
- corrosion of equipment
- contamination of the equipment (e.g., dust, moisture)
- animals, tools, or fallen parts that short-circuit the equipment
- poor maintenance
- workers using improper or non-rated tools.

If a worker is close to energized electrical equipment, the worker may be exposed to a flash hazard, even if the source of the arc flash is not being worked on. Employers and supervisors need to ensure these workers are protected from flash hazards, and should educate workers on flash hazard recognition.

It may be possible to eliminate the electrical hazard with equipment designed to offer flash protection. The plug in the picture at right and below is designed for flash protection and can be used as a disconnect switch.



Flash protection is designed into this disconnect switch/plug



Mechanical workers that are potentially exposed to arc flash should always wear clothing that provides for some level of arc-flash protection. Clothing made of synthetic fibres can be readily ignited by arc flash and melt to the workers skin. Cotton or wool fabrics are more flame-retardant and are therefore recommended as outer-wear and inner-wear for work clothes. Clothing that is flame resistant (FR) and rated to provide protection up to a specified hazard category must be worn when there is a flash hazard.

Protection from an arc flash is afforded by protective clothing and equipment such as

- wearing flame-resistant clothing
- flame-resistant eye protection (flame-resistant face shield is often required as well)
- hand protection
- hearing protection.

There are a number of levels of flame-resistant (FR) clothing, ranging from cotton clothes to the flash suits and face shields shown in the accompanying image. The level of protection necessary is determined by a calculation using tables or a computer program.

A hypothetical example:

For voltage testing on an energized part, 240 volts or less, a worker may require

- FR-rated pants and shirt (each rated to withstand 4 calories/cm²)
- FR-rated safety goggles
- 500-volt-rated class 00 gloves (class 0 gloves protect up to 1000 volts)
- 1000-volt-rated tools
- approved hard hat.

Actual calculations for this task may yield different results.

Workers that encounter a flash hazard can take additional precautions to reduce exposure.

- Standing as far away as possible from the hazard lowers the calorie intensity of an arc flash.
- Standing to the side when opening electrical-box doors can reduce exposure to the full force of a blast.

Information is available to assist with arc-flash energy calculations. Here are some sources:

- The (US) National Fire Protection Association's *Standard for Electrical Safety in the Workplace* (NFPA 70E). Contact the NFPA: 1-800-344-3555, www.nfpa.org.



A flash suit and face shield are required for the more powerful flash hazards.

- The Institute of Electrical and Electronics Engineers' standard 1584, Guide for Performing Arc-Flash Hazard Calculations. Contact the IEEE: 1-800-678- 4333, www.ieee.org.
- CSA standard Z462 *Workplace Electrical Safety* is currently being developed. Upon completion in 2008, CSA Z462 will be another resource of information dealing with electrical safety concerns such as arc flash. Contact the CSA: 1-800-463-6727, www.csagroup.org

WORKING ON ENERGIZED SYSTEMS

What if there's an electrical hazard but work must be done on or near enough to the hazard to make electrical contact, or near enough to be exposed to injury from an arc flash? In such cases, work while the system is energized is permitted only if specific conditions are met.

Work on energized equipment is permitted only if

- it is not reasonably possible to disconnect the equipment, installation, or conductor from the power supply,
- the equipment is rated at a nominal voltage of 600 volts or less, and disconnecting the equipment would create a greater hazard to workers than proceeding without disconnecting it, or
- the work consists only of diagnostic testing.

Note: Testing with a meter **is** working on energized equipment, and requires appropriate protection including personal protective equipment.

Unless the work consists only of diagnostic testing or involves a nominal voltage under 300 volts, an adequately equipped competent worker who can perform rescue operations, including cardiopulmonary resuscitation (CPR), must be stationed where he or she can see the workers performing the live work.

Work on energized equipment nominally rated greater than 400 amperes and greater than 200 volts, or greater than 200 amperes and greater than 300 volts, can only be done if

- 1) the owner of the equipment provides the employer and the constructor with a record showing that it has been maintained according to the manufacturer's specifications
- 2) a copy of the maintenance record is readily available at the project
- 3) the employer has determined from the maintenance record that work on the equipment can be performed safely without disconnecting it, and
- 4) before beginning live work, the worker has verified that requirements 1), 2), and 3) have been met.

Repair or permanently disconnect defective equipment.

Section 2-300 of the *Ontario Electrical Safety Code* requires operating electrical equipment to be kept in safe and proper working condition.

The constructor must ensure that written procedures for work on or near live equipment are produced and implemented to protect workers from electrical shock and burn. The constructor must have copies of the procedures available for employers on the project.

The employer must provide and explain the written procedures to workers before they start work on or near live equipment. The constructor and the employer both have a general duty to ensure that the health and safety of workers are protected.

Operating equipment near energized powerlines

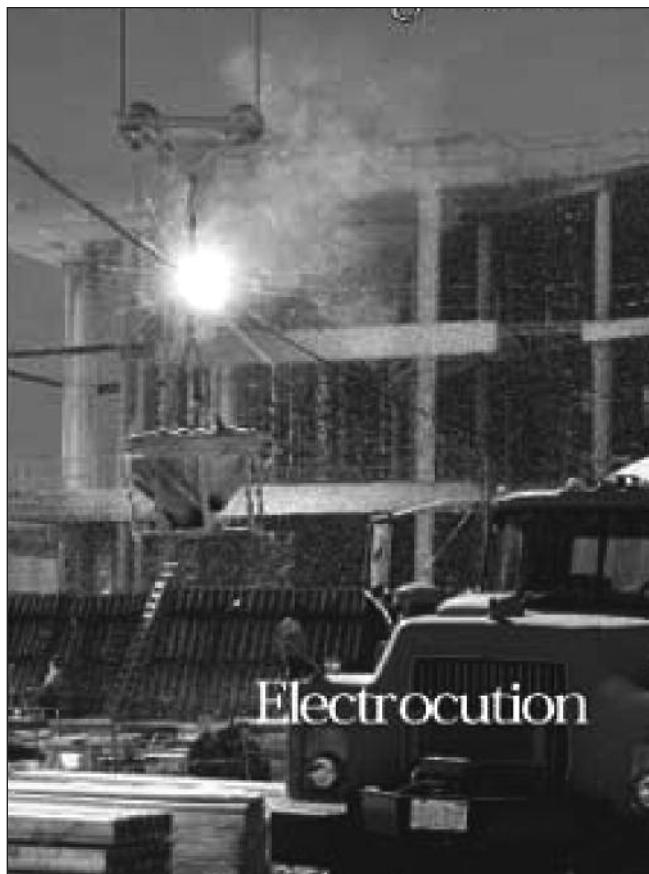
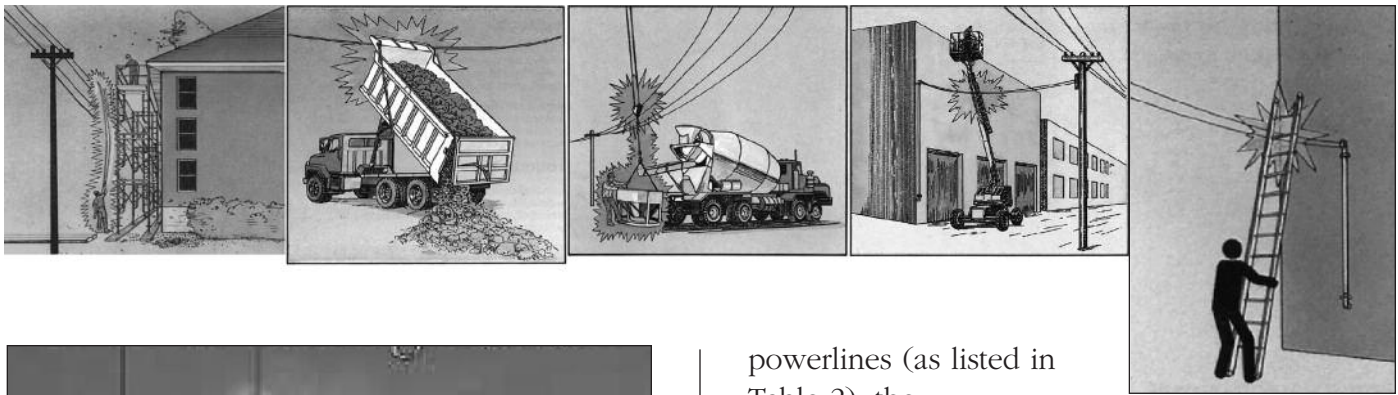
Incidental powerline contact happens too often, especially considering the potential severity of the consequences. The Ministry of Labour reported 108 powerline contacts in 1998. That number rose to 196 in 2005. See Table 1.

Constructors must be aware of electrical hazards when equipment such as a crane, dump truck, or other vehicle is going to be operated near an energized overhead electrical conductor, or when excavating equipment such as a backhoe will be operated near underground powerlines.

Table 1: Summary of Powerline Contacts

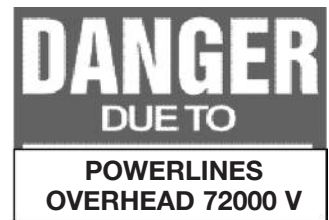
Overhead Lines					Buried Cables		
Year	Crane	Dump truck	Tree felling	Other	Digging	Other	Total
2005	19	21	9	87	45	15	196
2004	11	16	5	57	53	9	151
2003	16	19	9	63	35	6	148
2002	16	20	4	50	36	6	132
2001	16	22	5	43	27	7	120
2000	15	10	3	59	32	3	122
1999	11	26	2	48	27	1	115
1998	10	17	8	39	27	7	108
TOTALS	114	151	46	446	282	54	

(Source: Ontario Ministry of Labour)



When equipment operates within reach of, and could therefore encroach on, the minimum permitted distances from live overhead

powerlines (as listed in Table 2), the constructor is required to have written procedures in place to prevent it from occurring and to have copies of the procedure available for every employer on the project.



Overhead powerlines are most frequently hit by dump trucks and cranes; however, elevating work platforms and low-tech equipment such as ladders and rolling scaffolds are also involved. Keep in mind that many powerline contacts involve low-voltage service and buried cable.

Safety measures

Written measures and procedures required by the Construction Regulation include the following:

- Place enough warning devices in the area of the hazard so at least one is always visible to the operator. The warning devices must be visible to the operator under any conditions in which the

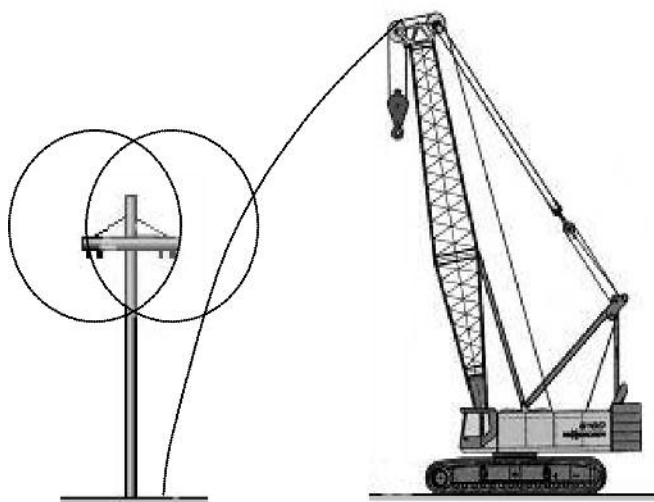
Table 2

Normal phase-to-phase voltage rating	Minimum distance
750 or more volts, but no more than 150,000 volts	3 metres
More than 150,000 volts, but no more than 250,000 volts	4.5 metres
More than 250,000 volts	6 metres

The wind can blow powerlines, hoist lines, or your load. This can cause them to cross the minimum distance.

equipment may be operating (night, rain, fog, etc.), and must be specific about the hazard. Provide a sign meeting the requirements of the Construction Regulation's section 44, stating, for example, "Danger! Electrical power lines overhead." We recommend that you include the voltage.

- Ensure the equipment operator has been provided with written notification of the electrical hazard before beginning the work.
- Ensure there is a sign warning of the hazard that is visible to the operator at the operator's station. This may come as a sticker with the machine. Check to ensure the sticker is still legible.
- Before the operator starts work, ensure that the employer of the equipment operator provides and explains the procedures to the equipment operator.
- A competent worker must be designated as a signaller to warn the operator when any part of the equipment, load, or hoist line may approach the minimum distance. The signaller must then be in full view of the operator and have a clear view of the equipment and the conductor. Section 106



Inside the limit of approach to the powerline.

of the Construction Regulation also applies with respect to the designated signaller.

An exemption to these measures is only allowed if under the authority of the owner of the electrical conductor (typically the local utility), protective devices and equipment are installed, and written procedures are implemented (for example, using the Electrical & Utilities Safety Association (E&USA)'s *Electrical Utilities Safety Rules*) that are adequate to protect the equipment operator from electrical shock and burn.

Prevention

Ensure that contractors and workers understand that work should be planned to avoid powerlines. Prepare for work that must be done in close proximity to energized powerlines by developing written procedures ahead of time. Have overhead powerlines moved, insulated, or de-energized where possible. Insulating or "rubberizing" powerlines offers some protection against brush contact in some circumstances. The local utility may provide this service.



Identify the voltage of the service by checking markings on the utility pole and calling the utility. If material must be stored under powerlines, hang warning flags and signs to inform workers about the hazard and the need to obtain written procedures if hoisting.

Provide instruction as part of site orientation:

- Advise operators of large equipment where overhead and buried powerlines are and where overhead powerlines may be lower than expected.
- Remind workers not to let a ladder, scaffold, or elevated work platform lean or drift toward overhead powerlines. Always maintain minimum allowable clearances.

- Inform all workers how powerline hazards are identified on site and that written procedures are required prior to operating near them.
- Review an appropriate emergency response for equipment operators and workers assisting operators, in case contact should occur.

In the event of contact between equipment and overhead powerlines:

1. **Stay on equipment.** Don't touch equipment and the ground at the same time. Touching anything in contact with the ground can be fatal. Stay on the equipment unless forced off because of a life-threatening hazard such as fire.
2. **Keep others away.** Warn everyone not to touch the equipment or its load. That includes buckets, outriggers, load lines, and any other part of the machine. Beware of time-delayed relays. After line damage trips a breaker, relays may still try to restore power. They may reset automatically two or three times.
3. **Break contact.** If possible, break contact by moving the equipment clear of the wires. This may not be feasible where contact has welded conductors to equipment, the hoist line, or the load.
4. **Call the local utility.** Get someone to call the local electrical utility for help. Stay on the equipment until the utility shuts down the line and *confirms* that power is off. Report incidents of powerline contact so that the utility can check for damage that could cause the line to fail later.
5. **Jump clear.** If forced to leave the equipment, jump carefully *off* the equipment onto the ground landing only on your feet, with your feet together.
Touching the equipment and the ground at the same time can be fatal.

Touching the ground at different points can also be fatal. Shuffle slowly away from the equipment using very small steps to minimize the contact area with the ground.

6. **Report the contact.** See "Reporting Electrical Accidents/Incidents" in this chapter.

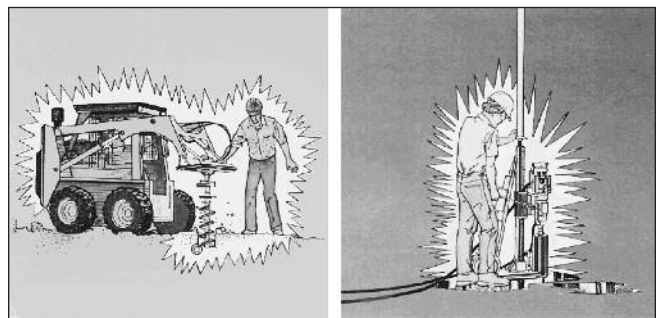
Hidden power supplies

Digging into buried cable resulted in 282 powerline contacts between 1998 and 2005 (see Table 1). A great many of these resulted from excavating prior to getting a locate on the service. If the electrical power cannot be shut off during excavation, the owner (of the service) must be present to supervise the uncovering of the powerline.

The following are some prevention measures for hidden powerlines.

For underground powerlines:

- Before excavating, request that the owner of the service locate and mark underground powerlines.
- Contact the utility through Ontario One Call to locate all underground services.
- Locate and mark underground lines on drawings that will be used for excavating.
- Post warning signs along the route of underground powerlines.
- When operators of excavation equipment arrive on site, advise them where underground services are located and how they are identified.



For powerlines embedded in concrete:

- Ensure various trades provide sleeving when concrete is poured to reduce the need to drill.
- Try to have powerlines laid along dedicated sections of flooring and walls.
- Mark powerline locations on drawings that will be referenced for drilling.
- Use a location service to ex-ray the concrete and locate embedded powerlines.

MULTIMETERS

In the process of troubleshooting, electrical workers face the risk of injury from improper multimeter selection or use. Multimeters that are designed to meet the International Electrotechnical Commission (IEC) 1010 and overvoltage category standards, when properly used, offer the electrician an acceptable level of protection that is recognized by the electrical industry. The use of fused leads provides additional protection for the worker.

Why use overvoltage category rated multimeters?

Momentary high-voltage transients or spikes can travel through a multimeter at any time and without warning. Motors, capacitors, lightning, and power conversion equipment such as variable speed drives are all possible sources of spikes.



A failed multimeter

The IEC 1010 standard defines categories I through IV that are abbreviated as CAT I, CAT II, CAT III, etc. The higher-numbered categories represent an electrical environment that is susceptible to higher-energy spikes. For example, multimeters that are designed to the CAT IV standard provide the worker more protection from high transient voltage spikes than do CAT III, CAT II, or CAT I designs. See the diagram on the next page and Table 3 below for an explanation of each category.

Be sure that the multimeter model has been tested. Simply being designed to the CAT III standard, for example, does not mean the multimeter was also *tested* to that standard.

Look for proof of independent testing by an organization accredited by the Standards Council of Canada, such as the CSA (Canadian Standards Association) International logo, along with the appropriate category *rating* on the equipment. Test



Table 3

OVERVOLTAGE CATEGORY	IN BRIEF	EXAMPLES
CAT IV	Three-phase at utility connection, any outdoors conductors	<ul style="list-style-type: none"> • Refers to the "origin of installation", i.e., where low-voltage connection is made to utility power. • Electricity meters, primary overcurrent protection equipment. • Outside and service entrance, service drop from pole to building, run between meter and panel. • Overhead line to detached building, underground line to well pump.
CAT III	Three-phase distribution, including single-phase commercial lighting	<ul style="list-style-type: none"> • Equipment in fixed installations, such as switchgear and polyphase motors. • Bus and feeder in industrial plants. • Feeders and short branch circuits, distribution panel devices. • Lighting systems in larger buildings. • Appliance outlets with short connections to service entrance.
CAT II	Single-phase receptacle connected loads	<ul style="list-style-type: none"> • Appliance, portable tools, and other household and similar loads. • Outlet and long branch circuits. <ul style="list-style-type: none"> • Outlets at more than 10 meters (30 feet) from CAT III source. • Outlets at more that 20 meters (60 feet) from CAT IV source.
CAT I	Electronic	<ul style="list-style-type: none"> • Protected electronic equipment. • Equipment connected to (source) circuits in which measures are taken to limit transient overvoltages to an appropriately low level. • Any high-voltage, low-energy source derived from a high-winding resistance transformer, such as the high-voltage section of a copier.

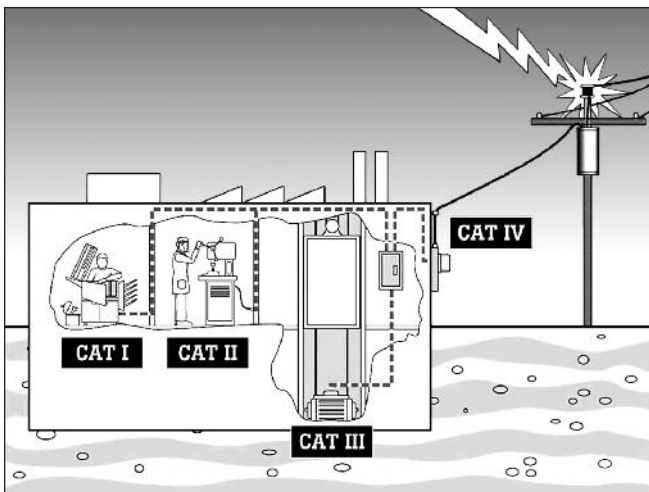
Reprinted in part with permission of Fluke Electronics Canada Inc.

leads should also be rated at the same or greater voltage than the multimeter.

Understanding overvoltage installation categories

The division of a power distribution system into categories is based on the fact that a dangerous high-energy transient such as a lightning strike will be attenuated or dampened as it travels through the impedance (AC resistance) of the system. A higher CAT number refers to an electrical environment with higher power available and higher-energy transients.

Therefore, a multimeter designed to the CAT III standard is resistant to much higher-energy transients than one designed to the CAT II standard. *Categories I through IV apply to low voltage (less than 1000 V) test equipment.*



Safe use of multimeters

- Use only multimeters that display **both** the CSA logo (or equivalent) **and** the CAT (I, II, III, or IV) designation. *Categories I through IV apply to low voltage (less than 1000 V) test equipment.*
- Check to ensure that the meter's voltage rating is appropriate for the work being done. *Be aware of multimeters with maximum voltage ratings typical of other countries (550 V for example).*
- Use personal protective equipment such as arc flash fire-resistant clothing; eye and

face protection; long sleeve shirts; dielectric safety boots; rubber gloves with leather protectors; and mats, blankets, or shields as required. **Do not wear synthetic inner or outer clothing that can melt if an arc flash occurs.**

- Check the manufacturer's manual for special cautions. Moisture and cold may affect the performance of your meter.
- Wipe the multimeter and test leads clean to remove any surface contamination prior to use.
- Use fused test leads. Ensure fused leads and internal probe fuses are rated as high as or higher than the equipment you are going to work on. A minimum of 30 kA is recommended (200 kA is desirable).
- Ensure that test leads are in the correct input jacks.
- When the values to be measured are uncertain, start testing with high ranges of the multimeter, then move to the lower ranges.
- Connect to the ground first, and disconnect from ground last.
- Test the multimeter on a known power source to verify that the meter is functioning properly before and after testing the suspect circuit, using the same power function for all three tests.

Using a meter to confirm zero energy for a lockout

Set the meter to the power function to be used for validating the zero energy. Test to ensure the meter is functioning correctly by testing on a known power source, then test the locked out circuit to verify the power has been effectively isolated, and finally re-test on the same known power supply to verify the meter's fuse has not blown and the meter is still functioning correctly on that power setting.

PORTABLE TOOLS AND EXTENSION CORDS

1. Unless they are double-insulated, tools must have:
 - a) the casing grounded
 - b) a polarized plug connection.
2. Extension cords must be of the outdoor type, rated for 300 volts, and have an insulated grounding conductor.
3. Defective cords must not be used. They should either be destroyed or tagged and removed from the jobsite until they are repaired.
4. Extension cords should be protected during use to prevent damage.
5. Extension cords should be plugged into Class A GFCIs. When built-in GFCI receptacles are not available, protection can be attained with an in-line GFCI plugged directly into the supply receptacle. **Electric tools used outdoors or in wet locations must be protected by a Class A GFCI.**



In-line Class A GFCI.

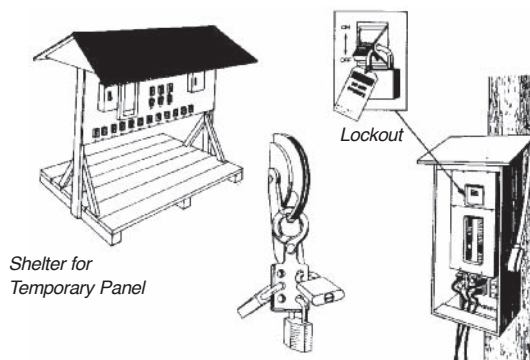
TEMPORARY WIRING AND POWER

1. **Temporary wiring** for construction or demolition projects must be installed in accordance with the Ontario Electrical Safety Code 23rd Edition/2002 (as amended by O. Reg. 62/07). Copies

available from Orderline at 1-888-361-0003 or www.orderline.com.

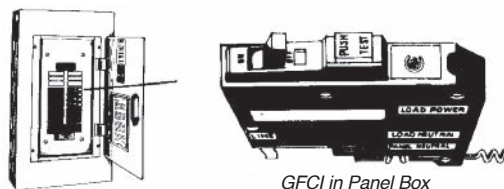
2. A switch and panel board,

- a) must be securely mounted on a soundly constructed vertical surface;
- b) must have a cover over uninsulated parts carrying current;

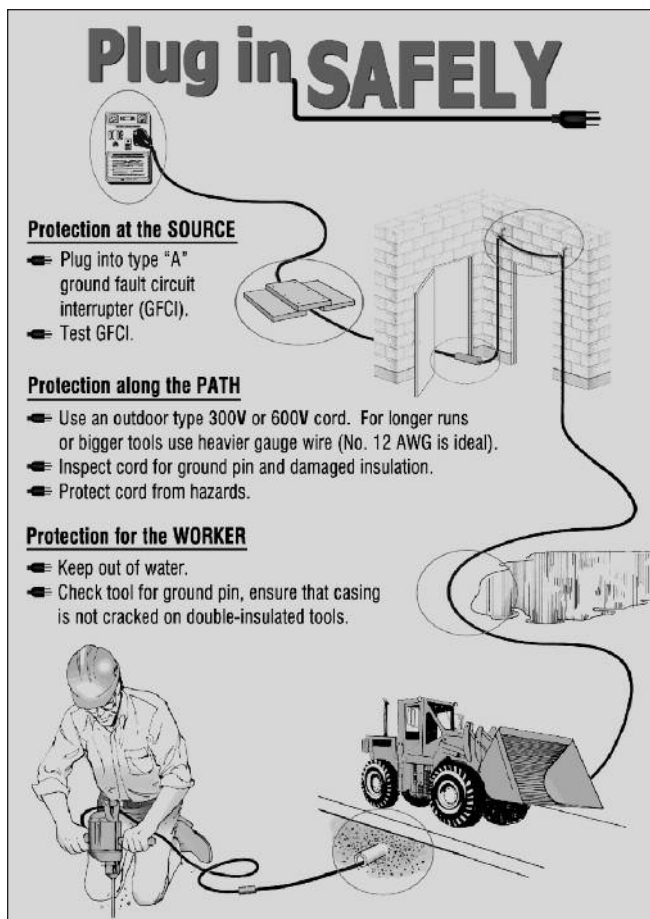


Shelter for Temporary Panel

- c) be located,
 - in an area where water will not accumulate; **and**
 - within easy reach of workers and readily accessible to them;
- d) must be kept clear of obstructions in the area in front of the panel board;
- e) that controls a service entrance, service feeder or branch circuit providing temporary power,
 - must not be locked in the energized position; **and**
 - must be housed in an enclosure that can be locked and is provided with a locking device.
- f) When supplying power to tools that will be used outdoors or in wet locations, the receptacle must be protected by a class A ground fault circuit interrupter (GFCI).



GFCI in Panel Box



3. **Portable generators** for use as a stand-alone supply for portable electrical devices must be labelled **“Neutral Bonded To Frame.”**

“Portable Generators for portable electrical devices shall be a generator with the neutral bonded to the case to facilitate the operation of the overcurrent protection device(s).” Labelling on newer portable generators must indicate the status of the neutral conductor and shall be marked on



Labelled “Neutral Floating”

each machine as follows: NEUTRAL BONDED TO FRAME or NEUTRAL FLOATING.

Electrical Safety Authority Flash notice 03-03-FL

Portable generators with no connection between the neutral and the case cannot be used for a stand-alone electrical supply for the operation of portable electrical equipment. Generators with no connection between the neutral and the case are intended to be connected to a distribution system through a transfer switch. An example of this is a standby backup system in a residential home which kicks in upon failure of the utility supply. These generators will be labelled **“Neutral Floating”**.

OTHER ELECTRICAL ISSUES

Electromagnetic induction

Electromagnetic induction can create an electric current in a dead circuit. The condition occurs when a magnetic field from another wire, circuit, or device cuts across a wire in its path and produces a charge in that wire. Temporary grounding will prevent electromagnetic induction. The temporary grounding cable must be the same size conductor as the one found within the circuit.

Grounding

A ground conductor provides a direct physical connection to the mass of the earth.

A grounding conductor limits the voltage or current to the ground during normal operation, and also prevents excessive voltages due to lightning strikes.

A temporary ground provides a direct physical connection to the mass of the earth. Temporary grounding typically involves the use of a wire or cable that has one end connected to a de-energized circuit, and the other end to a known grounded connection. The known grounded connection can be the equipment frame (note that if the equipment is electrically isolated, the frame may not provide an effective grounded

connection), a metal water pipe, a ground electrode, or other acceptable grounding medium.

Ground all phases. Attach a temporary ground cable to the system and keep it in place until work is completed.

Connecting and disconnecting conductors

Disconnect devices used to isolate electrical equipment must be certified by CSA International or another certification body accredited by the Standards Council of Canada. It is important that the device has the appropriate rating for the available current and load it is serving. Never assume a circuit has been de-energized when the disconnect is in the open position. Check for power in all conductors, then follow prescribed lockout and tagging procedures before beginning work.

Capacitors

Isolate the capacitor by opening the circuit breaker or the isolation device connecting it to the circuit. Drain off the accumulated charge for five to ten minutes with the system device. Short circuit and ground the capacitor using a hot stick and required personal protective equipment.

Electrical fires

Never put water on fires in live electrical equipment or wiring. Water is a conductor and increases the risk of arc flash and electrocution. An electrical fire in a confined space can rapidly deplete oxygen and may release toxic fumes. If possible, switch off power. Avoid inhaling fumes and vacate the area at once. If necessary, breathe through a damp cloth and stay close to the floor. Use a Class C fire extinguisher. Intended for electrical fires, Class C extinguishers employ a non-conductive extinguishing agent. An ABC fire extinguisher may also be used on an electrical fire. Every worker who may be required to use a fire extinguisher must be trained in its use. Report fires immediately. Wiring or equipment involved

in a fire must be inspected by the electrical utility inspector before being reactivated.

REPORTING ELECTRICAL ACCIDENTS/INCIDENTS

All accidents, regardless of severity, must be reported promptly to management and the immediate supervisor, and a record should be kept at the jobsite. When a serious or fatal injury involves a union member, the union office and steward must be notified immediately. Labour and management should cooperate fully in conducting an investigation.

Part VII of the *Occupational Health and Safety Act* specifies the requirements for notification in the event of fatalities, injuries, and accidents. In the event of an accident that requires reporting and investigation, care should be taken not to disturb the accident scene, nor should equipment or tools involved in the accident be removed.

Contact with an overhead powerline

Contact with an overhead powerline must be reported to multiple parties.

If accidental contact occurs with an energized powerline carrying 750 V or more, report the contact to the inspection department of the Electrical Safety Authority (ESA), and provide written notice to the Ministry of Labour, joint health and safety committee or health and safety representative, and trade union.

Fatality or critical injury

A written report is required under subsection 51 (1) of the Act, respecting an occurrence in which a person is killed or critically injured. (See box on next page.)

Section 53 of the Act: Where a notice or report is not required under section 51 or 52, and an

- accident
- premature or unexpected explosion, fire, flood or inrush of water
- failure of any equipment, machine, device, article, or thing

- cave-in, subsidence, rockburst
- or other *incident as prescribed* (see box below)

occurs at a project site, mine, or mining plant, notice in writing of the occurrence shall be given to a director, the joint health and safety committee or health and safety representative, and trade union, if any, by the constructor of the project or the owner of the mine or mining plant within two days of the occurrence containing such information and particulars as are prescribed.

For the purpose of the Act, the Regulations, and the Ontario Electrical Safety Code, “critically injured” means an injury of a serious nature that,

- places life in jeopardy;
- produces unconsciousness;
- results in substantial loss of blood;
- involves the fracture of a leg or arm but not a finger or toe;
- involves the amputation of a leg, arm, hand, or foot but not a finger or toe;
- consists of burns to a major portion of the body; or,
- causes the loss of sight in an eye.

Note: *O. Reg. 834* and *Ontario Electrical Safety Code* (OESC) (twenty third edition 2002) use virtually identical wording for the definition of “critically injured.”

For the purpose of section 53 of the Act, a prescribed incident includes:

- accidental contact by a worker or by a worker’s tool or equipment with energized electrical equipment, installations or conductors. s.11 O. Reg. 213/91
- Accidental contact by a crane, similar hoisting device, backhoe, power shovel or other vehicle or equipment or its load with an energized electrical conductor rated at more than 750 volts. s.11 O. Reg. 213/91

Reporting serious electrical incidents to the ESA

An owner, contractor, or operator of a facility must report any serious electrical incident to the Inspection Department of the ESA within 48 hours after the occurrence.

“Serious electrical incident” means,

- Any electrical contact which causes death or critical* injury to a person, or
- Any fire or any explosion or any condition suspected of being electrical in origin which might have caused a fire, explosion, loss of life, critical* injury to a person, or damage to property, or
- Any electrical contact with electrical equipment operating at over 750 volts, or
- Any explosion or fire of electrical equipment operating at over 750 volts.

OESC 2002

* see definition of “critically injured” under “Fatality or Critical Injury” above.

Notice of accident, explosion or fire causing injury

If a person is disabled from performing his or her usual work or requires medical attention because of an accident, explosion, or fire at a workplace, but no person dies or is critically injured because of that occurrence, the employer shall, within four days of the occurrence, give written notice of the occurrence containing the prescribed information and particulars to the following:

1. The joint health and safety committee or the health and safety representative, and the trade union, if any.
2. The Director, if an inspector requires notification of the Director.

27 LOCKOUT AND TAGGING

CONTENTS

- What is lockout and tagging?
- Forms of energy
- Procedure
- Planning steps
- Explanation of steps
- Summary

WHAT IS LOCKOUT AND TAGGING?

Lockout and tagging ensures that hazardous energy sources are under the control of each worker. Serious or fatal accidents can occur when people assume that machinery is turned off or made harmless—*but it isn't*.

Lockout is a procedure that prevents the release of hazardous energy. It often involves workers using a padlock to keep a switch in the “off” position, or to isolate the energy of moving parts. This prevents electric shock, sudden movement of components, chemical combustion, falling counterweights, and other actions that can endanger lives. Lockout is a physical way to ensure that the energy source is de-energized, deactivated, or otherwise inoperable.

Tagging tells others that the device is locked out, who has locked it out, and why. Tagged devices and systems must not be re-energized without the authority of those named on the tag.

FORMS OF ENERGY

When most people think of uncontrolled hazardous energy, they think of electricity. But construction crews doing work in industrial or office settings often have to lock out and tag a variety of energy sources. Here are the main types.

- **Electrical**—electrical panels, generators, lighting systems, etc.
- **Mechanical** (the energy of moving parts)—flywheels, blades, fans, conveyor belts, etc.
- **Potential** (stored energy that can be released during work)—suspended loads, compressed air, electrical capacitors, accumulated bulk goods, coiled springs, chemical reactions, changing states (solid—liquid—gas), etc.
- **Hydraulic**—presses, rams, cylinders, cranes, forklifts, etc.
- **Pneumatic**—lines, compression tanks, tools, etc.
- **Thermal**—steam, hot water, fire, etc.
- **Chemical**—flammable materials, corrosive substances, vapours, etc.

Some equipment may involve more than one type of energy, and pose unexpected hazards. For example, a machine may have an electrically operated component

with a hydraulic or pneumatic primary power source, or it may become activated on a timed schedule. With some equipment, gravity and momentum can present unexpected hazards.

You must recognize and control conditions such as these. Switches, power sources, controls, interlocks, pneumatics, hydraulics, computer-controlled sources, gravity-operated sources—all of these must be locked out and appropriately tagged by each worker involved.

PROCEDURE

Know the law

Section 188 of the Construction Regulation (O. Reg. 213/91) lists the requirements for lockout and tagging, including the requirement that “written procedures for compliance with this section shall be established and implemented.”

Many plants or industrial establishments will have specific procedures for lockout and tagging. This makes sense because the in-plant workforce will have proven its procedures through use on the particular system or machine in question.

Follow these procedures, but also verify that all energy sources have been isolated because construction work may differ from routine plant maintenance.

Plant personnel may shut down machines, equipment, or processes. In other cases, plant representatives may issue permits: 1) a work permit to allow work on their equipment and 2) a lockout permit to ensure that all lockout procedures are followed before work begins.

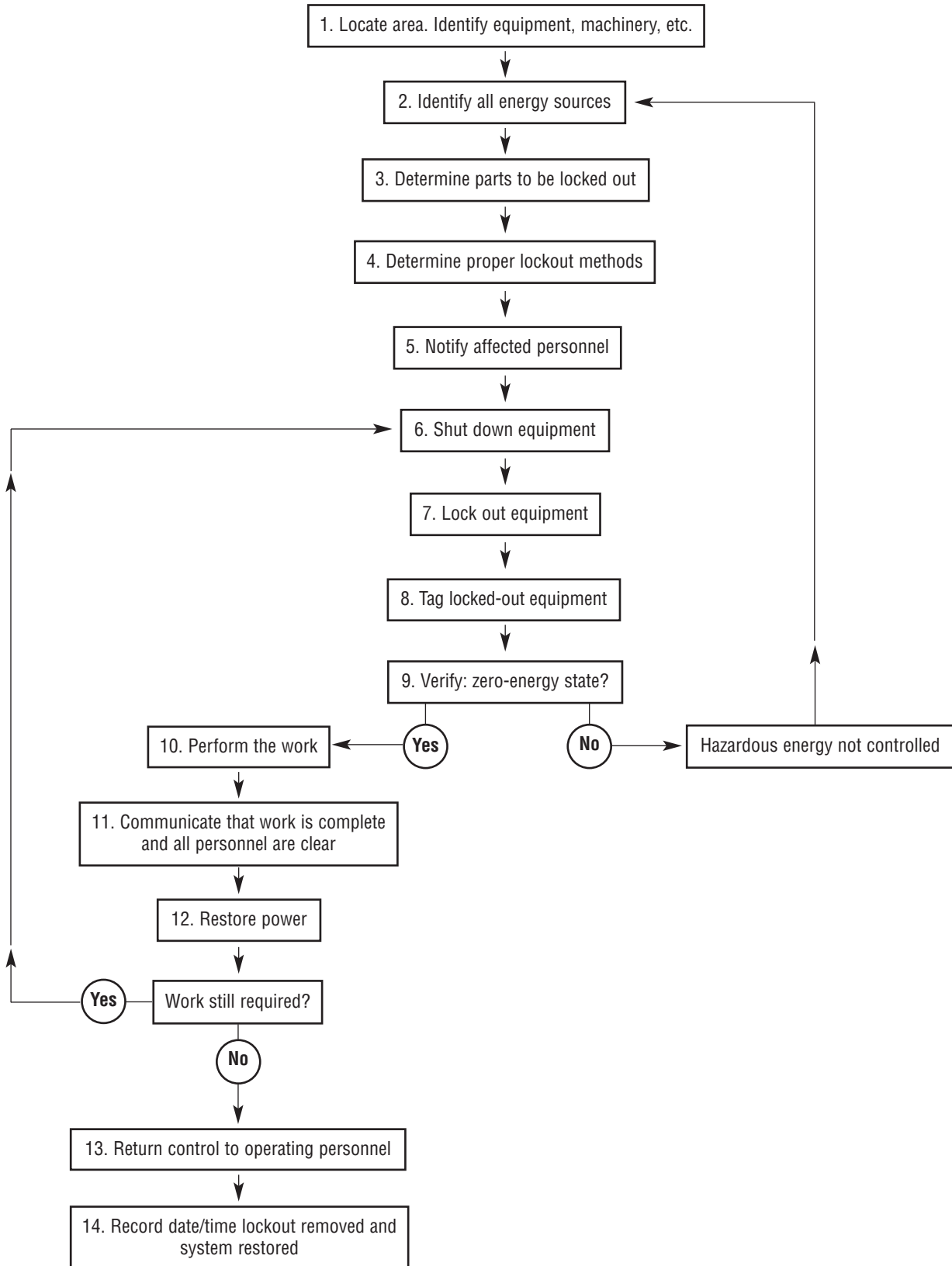
A written safe work procedure for lockout and tagging is essential. Once implemented and followed, a good procedure ensures that no form of energy can harm anyone during a lockout.

A written procedure helps to ensure that lockout and tagging have been thoroughly and effectively carried out before work begins. It should include

- training requirements for workers and supervisors
- quality, type, and colour of locks, scissors, chains, blanks, blinds, and other lockout devices
- method of identifying lock owners
- control of keys for locks
- colour, shape, size, and material for tags
- method of securing tags and information to be included
- communication and authorization procedure for shutting down and starting up machinery and equipment
- record-keeping requirements
- itemized steps to meet lockout objectives.

PLANNING STEPS

Specific lockout procedures will vary depending on the work and the processes which must be shut down. The following chart can help you develop specific procedures.



EXPLANATION OF STEPS

STEP 1: LOCATE WORK AREA AND IDENTIFY EQUIPMENT, MACHINERY, OR OTHER SYSTEM COMPONENTS TO BE WORKED ON

Identify the area with references such as floor, room name, elevation, or column number. Identify the equipment that is the subject of the work.

STEP 2: IDENTIFY ALL ENERGY SOURCES

Identify all energy sources affecting the equipment or machinery. Identify the various energy forms to be locked out such as electrical, momentum, pneumatic, hydraulic, steam, and gravity.

STEP 3: IDENTIFY THE PARTS TO BE LOCKED OUT OR ISOLATED

Identify systems that affect, or are affected by, the work being performed. These may include primary, secondary, backup, or emergency systems and interlocked remote equipment.

Review the current system drawings for remote energy sources and, where required, identify and confirm with the client or owner the existence and location of any switches, power sources, controls, interlocks, or other devices necessary to isolate the system.

Remember that equipment may also be affected by

- time restrictions for completing the work
- time-activated devices.

STEP 4: DETERMINE LOCKOUT METHODS

Confirm that the lockout of all energy sources is possible.

Some equipment may have to be kept operational to maintain service to other equipment that cannot be shut down. Take appropriate steps to provide protection for workers while working near operating equipment.

Equipment that can be locked out should be locked out by the methods most appropriate to the hazards.

STEP 5: NOTIFY ALL PERSONNEL AFFECTED

Shutting down equipment may affect operations in other locations, incoming shifts, or other trades who may be planning to operate the locked-out system. Before proceeding with the lockout, inform all personnel who will be affected.

At construction sites with a large workforce or at relatively large factories, you may need to have special communication methods and permits or approvals.

In-plant procedures specified by the owner or client take precedence over the procedures outlined here, provided there is no contravention of existing codes or laws.

STEP 6: SHUT DOWN EQUIPMENT AND MACHINERY

Qualified personnel must shut down the equipment, machinery, or other system components, placing them in a zero-energy state. Trace all systems to locate and lock out energy sources. The main source may be electrical, for instance, but pneumatic and other forms of energy may also be present. Always look for other possible energy sources.

All equipment capable of being energized or activated electrically, pneumatically, or hydraulically must be de-energized or de-activated by physically disconnecting or otherwise making the apparatus inoperable.

Always ensure that the client and operators are aware of the plan to shut down and lock out equipment, machinery, or other system components. In some cases, operations personnel or equipment operators may be required to shut down components because of their special qualifications or knowledge of the system.

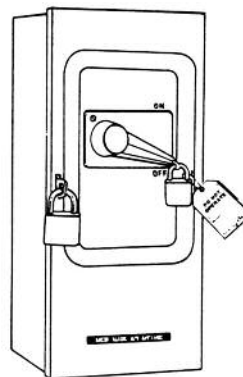
In determining what needs to be shut down and locked out, consider the different energy sources that may be found in the system.

STEP 7: INSTALL LOCKOUT DEVICES

After the circuit has been de-energized and locked out by the person in charge, each worker involved in the lockout must be protected by placing his or her personal lock on the isolating device.

Remember—even though the disconnect is already locked out, you are not protected until you attach your own personal safety lock.

Each worker must retain his or her key while the lock is in place. Only the worker in charge of the lock should have a key.



Remember . . .

- Merely removing a fuse doesn't constitute lockout. The fuse could be easily replaced. The fuse should be removed and the box locked out.
- The lockout devices attached to one system should not prevent access to the controls and energy-isolating devices of another system.

Locks

Locks should be high-quality pin-type, key-operated, and numbered to identify users.



Multiple locks and lockout bars

When several workers or trades are working on a machine, you can add additional locks by using a lockout bar. You can add any number of locks by inserting another lockout bar into the last hole of the previous bar.

Other lockout devices

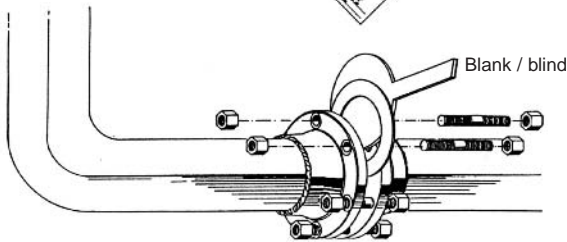
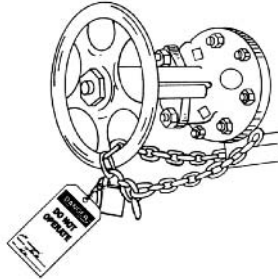
Scissors—have holes for locks and should be made of hardened steel.

Chains—should be high quality and snug fitting.

Blocks or cribbing—prevent or restrict movement of parts.

Blanks or blinds—are solid metal plates inserted at flanged connections to prevent the flow of liquids or gases.

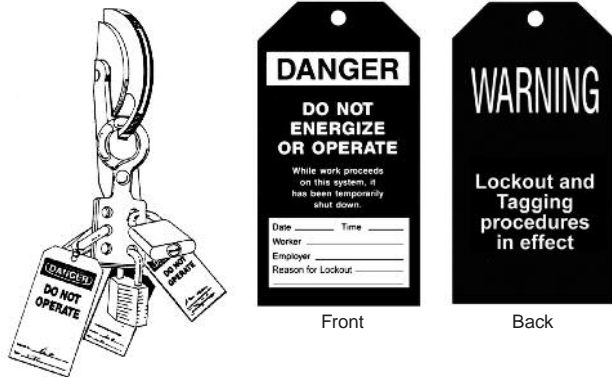
Pins and clamps—should be of high-quality materials and designed to fit the system.



STEP 8: TAGGING

Section 188 of the Construction Regulation (O. Reg. 213/91) requires each worker involved in a lockout operation to attach a durable tag to his or her personal lock. The tag must identify the worker's name, the worker's employer, the date and time of lockout, the work area involved, and the reason for the lockout.

A tag in itself offers no guarantee that a machine or system is locked out. It simply provides information.



Signs must be placed on the system indicating that

- it must not be energized or operated
- guards, locks, temporary ground cables, chains, tags, and other safeguards must not be tampered with or removed until
 - a) the work is complete, and
 - b) each worker has removed his or her personal lock.

A record must be kept of all equipment locked out or otherwise rendered inoperable so that all of these devices can be reactivated once the work is complete.

STEP 9: VERIFY ZERO-ENERGY STATE

After any power or product remaining in the equipment has been discharged or disconnected by qualified personnel, verify that all personnel are clear of the equipment. Then try, with extreme caution, to start the equipment manually. Look for any movement or functions. If none are observed, confirm that all energy sources are at a zero-energy state.

Test the system to ensure that all electrical components are de-energized and de-activated, including interlocking and dependent systems that could feed into the system, either mechanically or electrically.

STEP 10: PERFORM THE TASK

Carry out and complete the work assignment.

STEP 11: COMMUNICATE THAT WORK IS COMPLETE AND THAT ALL PERSONNEL ARE CLEAR

- Ensure that personnel are clear of the locked-out equipment, machinery, or system.
- Remove only **your** tags and locks.
- Tell personnel that were originally informed of the lockout that the equipment, machinery, or system is no longer locked out.

STEP 12: RESTORE POWER

Return systems to operational status and the switches to power ON. Have qualified personnel restart machinery or equipment.

STEP 13: RETURN CONTROL TO OPERATING PERSONNEL

When all work is completed, the person in charge of the lockout operation should formally return control of the equipment or system to plant personnel.

STEP 14: RECORD DATE/TIME LOCKOUT REMOVED AND SYSTEM RESTORED

This last step is important. It saves valuable information that may be lost if not recorded. Staff involved in the shutdown may not remain at the same jobsite. Owners or operators may require this information to help plan future shutdowns.

SUMMARY

Lockout can ensure the safety of a single mechanic working alone or of hundreds of workers in a factory. In either situation, a procedure for safe lockout and tagging must be written, implemented, and followed step by step.

Lockout and tagging procedures help to ensure that

- all energy sources are identified and locked out
- energy is not inadvertently restored while work is proceeding
- maintenance, repair, installation, and other jobs can be carried out safely
- records are kept.

28 BACKING UP

Reversing vehicles and equipment on construction projects pose a serious problem for personnel on foot.

Fatal accidents resulting from workers being backed over by dump trucks and other equipment occur all too frequently.

Anyone on foot in the vicinity of reversing vehicles and equipment is at risk. More than 20 deaths have occurred on construction sites over a ten-year period as a result of reversing vehicles.

Blind Spots

The main problem with reversing vehicles and equipment is the driver or operator's restricted view.

Around dump trucks and heavy equipment such as bulldozers and graders there are blind spots where the operator has no view or only a very limited view.

The operator may not see someone standing in these blind spots. Anyone kneeling or bending over in these areas would be even harder to see.

Consequently the driver or operator must rely on mirrors or signallers to back up without running over someone or into something. Figure 1 shows the blind spots for common types of construction equipment.

Dump trucks and cranes are the kinds of equipment that hit overhead powerlines most often. Beware of powerline contact whenever a crane, dump truck, or other vehicle is going to be operated near an overhead electrical conductor. If equipment operates within reach of (and could therefore encroach on) the minimum permitted distance from an overhead powerline (see the chapter on Electrical Hazards in this manual), the constructor is required to have written procedures in place to prevent the equipment from encroaching on the minimum distance.

Accident Prevention

To prevent injuries and deaths caused by vehicles and equipment backing up, there are four basic approaches:

- 1) site planning
- 2) signallers
- 3) training
- 4) electronic devices.

Site planning

Wherever possible, site planners should arrange for drive-through operations to reduce the need for vehicles to back up (Figure 2).

Foot traffic should be minimized where trucks and equipment operate in congested areas such as excavations. Where feasible, a barricade can help to

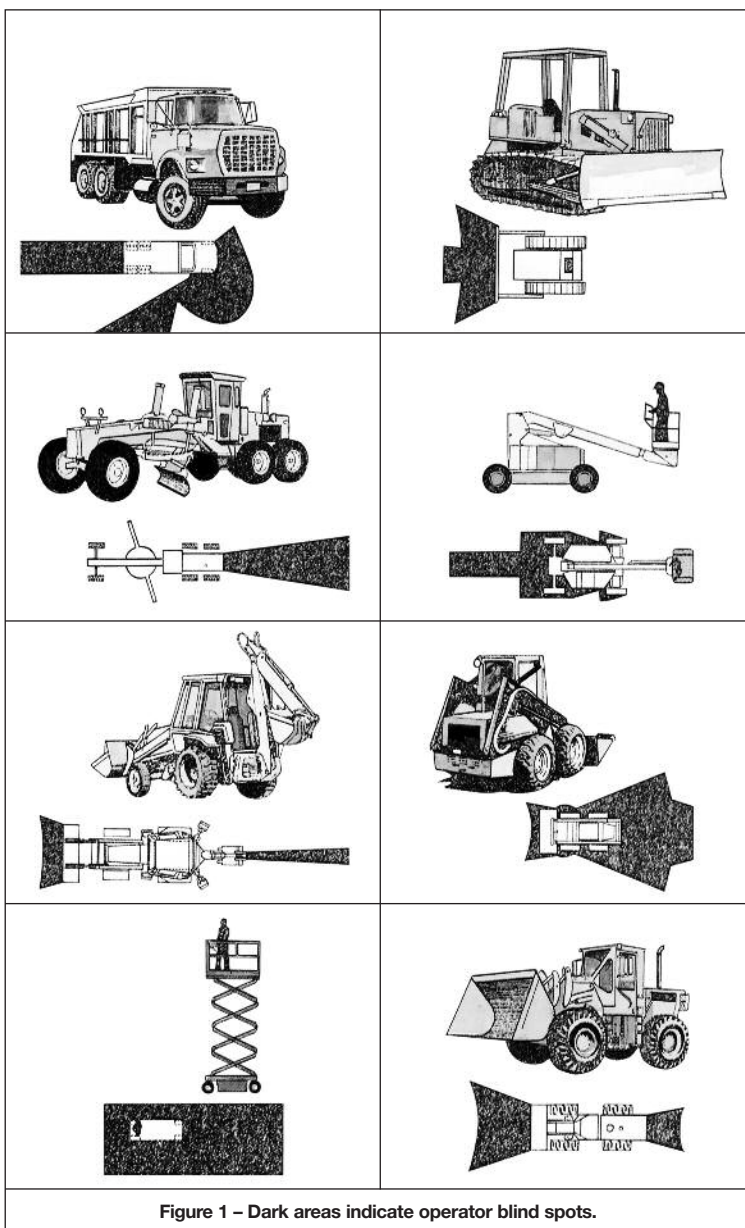


Figure 1 – Dark areas indicate operator blind spots.

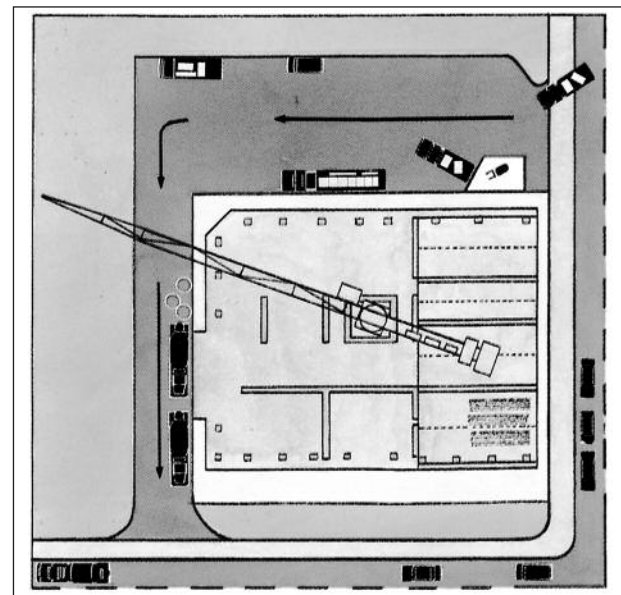


Figure 2



Figure 3

protect workers: for example, by keeping excavation work separate from forming operations (Figure 3).

The hazards of reversing vehicles can also be reduced through separate access for workers on foot. Where possible, for instance, a scaffold stair system should be provided for worker access to deep excavations.

Near loading and unloading areas, pedestrian walkways can be roped off or barricaded.

Signallers

On some projects, you cannot avoid having reversing vehicles or equipment on site. Often, they must share an area with other vehicles and operating equipment – as well as workers on foot.

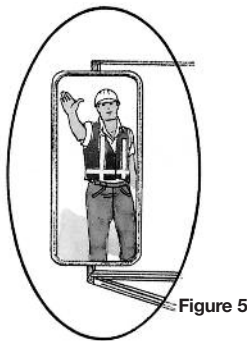


Figure 5

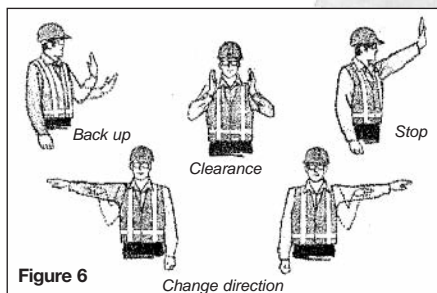
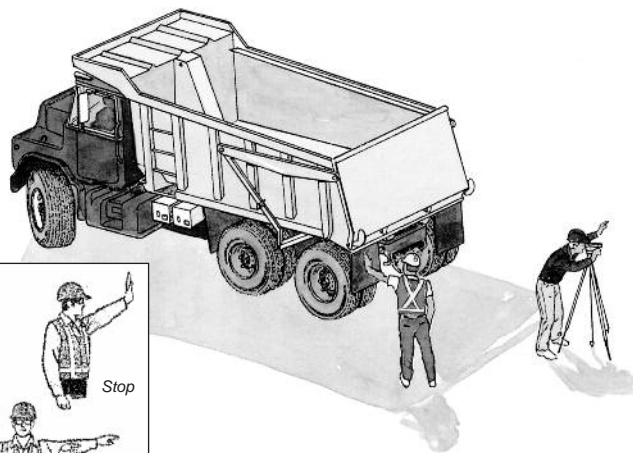


Figure 6



You must have a signaller or spotter when

- a vehicle or equipment operator's view of the intended path of travel is obstructed
- a person could be endangered by the operation of the vehicle or equipment, or by its load
- any part of the equipment could encroach on the minimum distance to an overhead powerline (see the chapter on Electrical Hazards in this manual for minimum distances).

A signaller must be a competent worker and must not have any other duties to fulfill while acting as a signaller.

Before a worker can act as a signaller, the employer must ensure that the worker has been given adequate oral and written instructions in a language that he or she understands. The employer must keep, on site, a copy of the written instructions and a record of the training.

A signaller must wear a garment – usually a nylon vest – that is fluorescent or bright orange, with 2 vertical 5-centimetre-wide yellow stripes on the front and 2 similar stripes forming a diagonal "X" pattern on the back. These stripes must be retro-reflective and fluorescent. The vest must have an adjustable fit and have a front and side tear-away feature.

If a signaller has to work during the night, he or she must wear retro-reflective silver stripes around each arm and leg.

The signaller must maintain clear view of the path that the vehicle, machine, or load will be travelling and must be able to watch those parts of the vehicle, equipment, or load that the operator cannot see. The signaller must maintain clear and continuous visual contact with the operator at all times while the vehicle or equipment is moving (Figure 5), and must be able to communicate with the operator using clearly understood, standard hand signals (Figure 6). The signaller must warn other workers on foot of the approaching vehicle or equipment, and must alert the operator to any hazards along the route.

Training

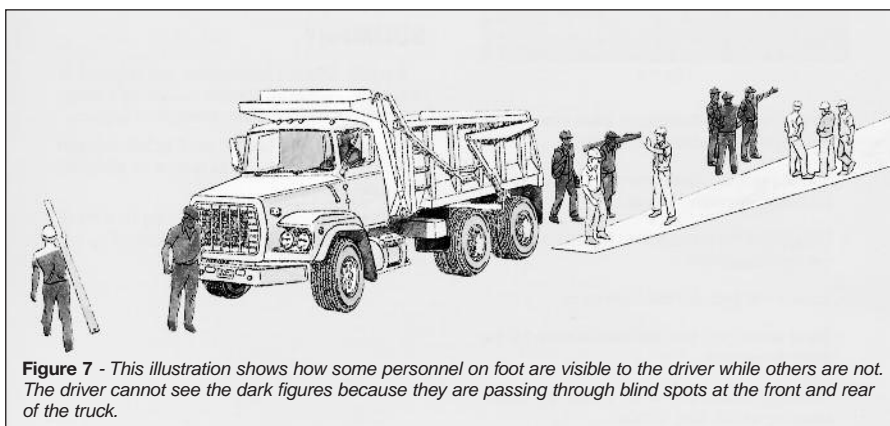
Instruction for drivers, operators, signallers, and workers on foot is essential to reduce the hazards created by reversing vehicles and equipment.

For example, all construction personnel must be made familiar with blind spots – the areas around every vehicle that are partly or completely invisible to the operator or driver, even with the help of mirrors (Figure 1).

Specific training can then focus on the following points.

Workers on Foot

- Know how to work safely around trucks and operating equipment.
- Understand the effect of blind spots (Figure 7).
- Avoid entering or standing in blind spots.
- **Make eye contact with the driver or operator before approaching equipment.**
- Signal intentions to the driver or operator.
- When possible, use separate access rather than vehicle ramps to enter and exit the site.
- Avoid standing and talking near vehicle paths, grading operations, and other activities where heavy equipment is moving back and forth.



- Stand where you can see and be seen by the driver or operator.
- Make eye contact with driver or operator before signalling or changing location.

Drivers and Operators

- Always obey the signaller or spotter. If more than one person is signalling, stop your vehicle and determine which one to obey.
- If possible, remain in the cab in areas where other equipment is likely to be backing up.
- Make sure that all mirrors are intact, functional, and properly adjusted for the best view.
- Blow the horn twice before backing up.
- When no spotter is present, get out and quickly walk around your vehicle. If the way is clear, back up at once (Figure 8).
- Stop the vehicle when a spotter, worker, or anyone else disappears from view.

Electronic Equipment

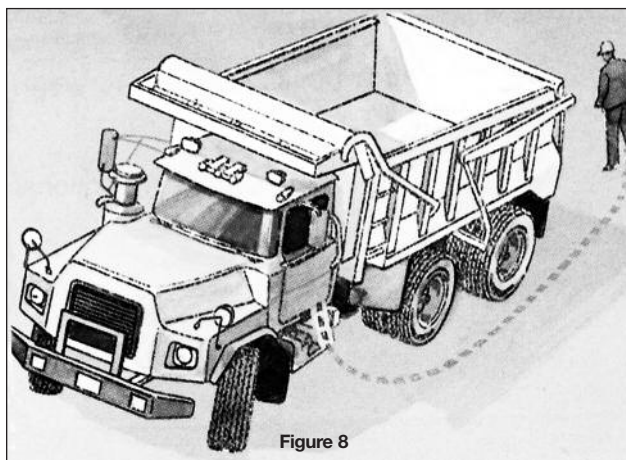
Since 2000, automatic audible alarms that signal when a vehicle is being operated in reverse have been required on dump trucks.

Alarms offer the greatest benefit when traffic is limited to only one or two vehicles. The warning effect of the alarm is greatly reduced, however, when it simply becomes part of the background noise on-site.

This is a common shortcoming with devices that sound continuously when the transmission is put in reverse, especially in areas where several vehicles are operating at once.

Newer devices using a type of radar to sense objects or people within a pre-set radius appear to be more effective but are not readily available or widely used.

Other technologies such as infrared or heat sensors and closed-circuit television are limited by the effects of vibration, dust, and dirt — conditions all too common on construction sites.



Signallers

- Stay alert to recognize and deal with dangerous situations.
- Know and use the standard signals for on-site traffic (Figure 6).
- Wear a reflective fluorescent or bright orange vest and a bright hard hat for high visibility.
- Use a signalling device such as a bullhorn in congested excavation areas.
- Understand the maneuvering limitations of vehicles and equipment.
- Know driver and operator blind spots.

29 TRAFFIC CONTROL

Attention: Supervisors

Traffic control persons (TCPs) must be given written and oral instructions regarding their duties. This section is designed to help you meet the requirement for written instructions set out in Section 69(4) of the Construction Regulation.

A worker who is required to direct vehicular traffic,

- (a) *shall be a competent worker;*
- (b) *shall not perform any other work while directing vehicular traffic;*
- (c) *shall be positioned in such a way that he or she is endangered as little as possible by vehicular traffic; and*
- (d) *shall be given adequate written and oral instructions, in a language that he or she understands, with respect to directing vehicular traffic, and those instructions shall include a description of the signals that are to be used.*

In addition, the written instructions must be kept on the project.

What are the objectives of traffic control?

- To protect construction workers and the motoring public by regulating traffic flow.
- To stop traffic whenever required by the progress of work. Otherwise to keep traffic moving at reduced speeds to avoid tie-ups and delays.
- To allow construction to proceed safely and efficiently.
- To ensure that public traffic has priority over construction equipment.

What equipment do I need?

Personal

- Hard hat that meets regulated requirements.
- Safety boots, CSA-certified, Grade 1 (green triangular CSA patch outside, green rectangular label inside).
- Garment, usually a vest, covering upper body and meeting these requirements:
 - fluorescent or bright orange in colour
 - two vertical yellow stripes 5 cm wide on front, covering at least 500 cm²
 - two diagonal yellow stripes 5 cm wide on back, in an X pattern, covering at least 570 cm²
 - stripes retro-reflective and fluorescent
 - vests to have adjustable fit, and a side and front tear-away feature on vests made of nylon.

We recommend that garments comply with CSA standard Z96-02—and in particular a Class 2 garment, Level 1 or Level 2.

Sign

A sign used to direct traffic must be

- octagonal in shape, 450 mm wide, and mounted on a pole 1.2 m long
- made of material with at least the rigidity of plywood 6 mm thick
- high-intensity retro-reflective red on one side, with STOP printed in high-intensity retro-reflective white

- 150 mm high
- on the other side, high-intensity retro-reflective micro-prismatic fluorescent chartreuse, with a black diamond-shaped border at least 317 mm x 317 mm, with SLOW printed in black 120 mm high.

After Dark

Section 69.1(4) of the Construction Regulation requires that you wear retro-reflective silver stripes encircling each arm and leg, or equivalent side visibility-enhancing stripes with a minimum area of 50cm² per side.

The following measures are recommended:

- Wear a hard hat with reflective tape.
- Use a flashlight with a red cone attachment as well as the sign and carry spare batteries.
- Place flashing amber lights ahead of your post.
- Stand in a lighted area under temporary or street lighting, or illuminated by light from a parked vehicle (stand fully in the light without creating a silhouette).

What are the requirements of a good traffic control person?

- Sound health, good vision and hearing, mental and physical alertness.
- Mature judgment and a pleasant manner.
- A good eye for speed and distance to gauge oncoming traffic.
- Preferably a driver's licence.
- The ability to give motorists simple directions, explain hazards, and answer questions.
- Liking, understanding, and respect for the responsibilities of the job.

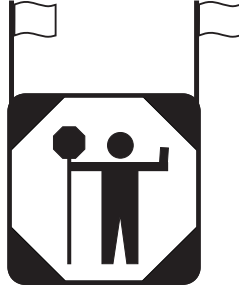
How do I prepare for each job?

Before starting work, make sure that you know

- the type of construction you will be involved with — paving, installing pipe, grading, cut and fill, etc.
- the type of equipment to be used, such as scrapers, trucks, compactors, and graders
- how the equipment will be operating — for instance, crossing the road, along the shoulder, in culverts, or on a bridge
- whether you will have to protect workers settling up components of the traffic control system such as signs, delineators, cones, and barriers
- any special conditions of the contract governing road use (for instance, many contracts forbid work during urban rush hours)
- how public traffic will flow — for example, along a two-lane highway, around curves or hills, by detour or on a road narrowed to a single lane. This last is a very common situation and requires two traffic control persons to ensure that vehicles do not move in opposing directions at the same time (see next page). In some cases, where the two cannot see one another, a third is necessary to keep both in view and relay instructions (see “Positioning of Traffic Control Persons,” next page).

What should I check each day?

- Make sure that the STOP-SLOW sign is clean, undamaged, and meets height and size requirements.
- Place the TRAFFIC CONTROL PERSON AHEAD sign at an appropriate distance to afford motorists adequate warning.
- Remove or cover all traffic control signs at quitting time or when traffic control is temporarily suspended.
- Arrange with the supervisor for meal, coffee, and toilet breaks.

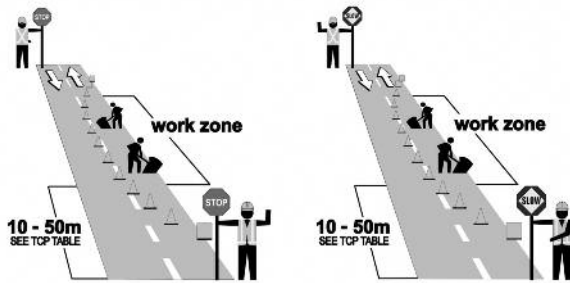


Where should I stand?

- Stand the correct distance from the work area. Refer to TCP Table on the following page.
- Do not stand on the travelled portion of roadway and always face oncoming traffic.
- Be alert at all times. Be aware of construction traffic around you and oncoming traffic on the roadway.
- Stand alone. Don't allow a group to gather around you.
- Stand at your post. Sitting is hazardous because your visibility is reduced and the ability of a motorist to see you is reduced.

TCP TABLE

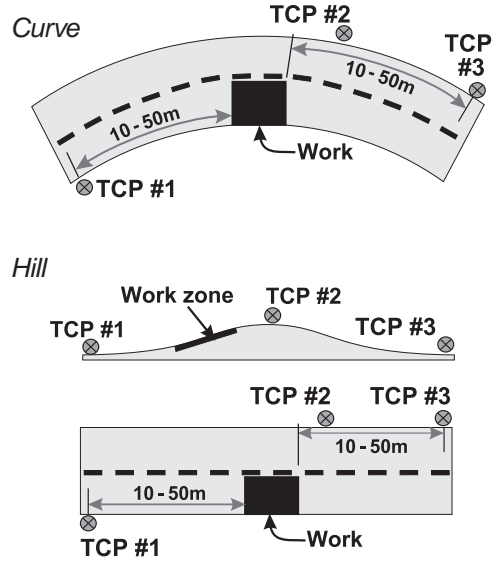
POSTED SPEED	60 km/h OR LESS, ONE LANE OR REDUCED TO ONE LANE IN EACH DIRECTION		70 km/h TO 90 km/h, ONE LANE OR REDUCED TO ONE LANE IN EACH DIRECTION	
	LOW	HIGH	LOW	HIGH
DISTANCE OF TCP FROM WORK ZONE	10 – 15 m	20 – 30 m	30 – 40 m	40 – 50 m



Typical Arrangement on Two-lane Roadway

- Adjust distances to suit road, weather and speed conditions. Remember these points:
 - Traffic must have room to react to your directions to stop (a vehicle can take at least twice the stopping distance on wet or icy roads).
 - Stand where you can see and be seen by approaching traffic for at least 150 metres (500 feet).
 - Avoid the danger of being backed over or hit by your own equipment.
- Hills and curves call for three TCPs or some other means of communication. The job of the TCP in the middle is to relay signals between the other two.

Positioning of Traffic Control Persons



Note: On curves and hills, three TCPs or some other means of communication are required.

The duty of TCP #2 is to relay signals between TCP #1 and #3.

- Once you have been assigned a traffic control position by your supervisor, look over the area for methods of escape — a place to get to in order to avoid being injured by a vehicle heading your way, if for some reason the driver has disregarded your signals. If this should happen, protect yourself by moving out of the path of the vehicle and then warn the crew.

Where am I not allowed to direct traffic?

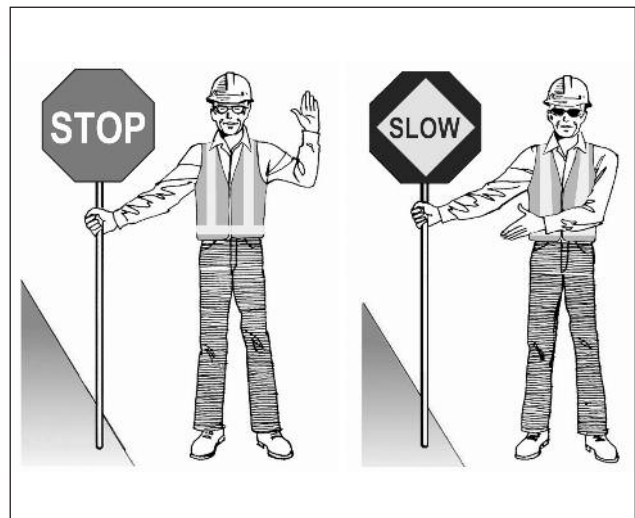
Section 69 of Ontario Regulation 213/91 specifies that:

A worker shall not direct vehicular traffic for more than one lane in the same direction. s. 69(2)

A worker shall not direct vehicular traffic if the normal posted speed limit of the public way is more than 90 kilometres per hour. s. 69(3)

How should I signal?

- Use the STOP-SLOW sign and your arms as shown below.



- Hold your sign firmly in full view of oncoming traffic.
- Give the motorist plenty of warning. Don't show the STOP sign when the motorist is too close. The average stopping distance for a vehicle travelling at 50 kilometres per hour (30 miles per hour) is 45 metres (150 feet). Higher speeds require more stopping distance.
- When showing the SLOW sign, avoid bringing traffic to a complete halt. When motorists have slowed down, signal them to keep moving slowly.
- When showing the STOP sign, use firm hand signals and indicate where you want traffic to stop. When the first vehicle stops, step into the centre of the road so the second vehicle can see you.
- Before moving traffic from a stopped position, make sure the opposing traffic has stopped and that the last opposing vehicle has passed your post. Then turn your sign and step back on the shoulder of the road.
- Stay alert, keep your eyes on approaching traffic, make your hand signals crisp and positive.
- Coordinate your effort with nearby traffic signals to avoid unnecessary delays, tie-ups, and confusion.
- Do not use flags to control traffic.
- In some situations, two-way traffic may be allowed through the work zone at reduced speed, with a traffic control person assigned to each direction. Since motorists can be confused or misled by seeing the STOP side of the sign used in the opposite lane, the signs must be modified. The STOP side must be covered to conceal its distinctive shape and command. This should prevent drivers from stopping unexpectedly.

How can I improve safety for myself and others?

- Don't be distracted by talking to fellow workers or passing pedestrians. If you must talk to motorists, stay at your post and keep the conversation brief.
- When using two-way radios to communicate with another traffic control person, take the following precautions:
 - Establish clear voice signals for each situation and stick to them.
 - Be crisp and positive in your speech.
 - Test the units **before** starting your shift and carry spare batteries.
 - Avoid unnecessary chit-chat.
 - Don't use two-way radios in blasting zones.
- When two traffic control persons are working together, you should always be able to see each other in order to coordinate your STOP-SLOW signs. Signals between you should be understood. If you change your sign from STOP to SLOW or vice-versa, you must signal the other person by moving the sign up and down or sideways. This will ensure that traffic control is coordinated. Two-way radios are the best way of communicating.

When you can't see the other traffic control person, a third should be assigned to keep you both in view.

What are my rights under the law?

Additional requirements for traffic control are spelled out in the **Ontario Traffic Manual, Book 7: Temporary Conditions**, available through Service Ontario Publications (1-800-668-9938). Ask for item number 170076. It can also

be downloaded for free from www.mto.gov.on.ca through a library search for the Ontario Traffic Manual.

The information applies to traffic control by any persons or agencies performing construction, maintenance, or utility work on roadways in Ontario.

The Construction Regulation under the *Occupational Health and Safety Act* makes it mandatory that traffic control persons be protected from hazards. This includes not only personal protective clothing and equipment but measures and devices to guard against the dangers of vehicular traffic. Safety should receive prime consideration in planning for traffic control. Regulations under the *Occupational Health and Safety Act* are enforced by the Ministry of Labour.

Traffic control persons have no authority under the *Highway Traffic Act* and are not law enforcement officers. If problems arise, follow these steps.

- Report dangerous motorists to your supervisor.
- Keep a pad and pencil to jot down violators' licence numbers.
- Ask your supervisor for assistance from police in difficult or unusual traffic situations.
- Never restrain a motorist forcibly or take out your anger on any vehicle.
- Always be alert to emergency services. Ambulance, police, and fire vehicles have priority over all other traffic.

Remember

- Always face traffic.
- Plan an escape route.
- Wear personal protective clothing.
- Maintain proper communication with other traffic control persons.
- Stay alert at all times.
- Be courteous.

Traffic control is a demanding job, often a thankless job, but always an important job. How well you succeed will depend largely on your attitude.

30 MOUNTING AND DISMOUNTING

Each year, workers are hurt while getting on or off trucks, backhoes, and other construction equipment. Learn the safe way to mount and dismount.

Three-point contact

When getting on or off equipment, you need three points of constant contact with the machine. That means one hand and two feet, or two hands and one foot – **at all times**.

Anything less, and you're risking a fall.

Three-point contact forms a triangle of anchor points which changes in form while you mount or dismount (Figure 1). You have the most stability when the centre of this triangle is close to your centre of gravity. Your weight should be evenly distributed among the three contact points. This means that you should avoid sideways movement because it can put you off balance.

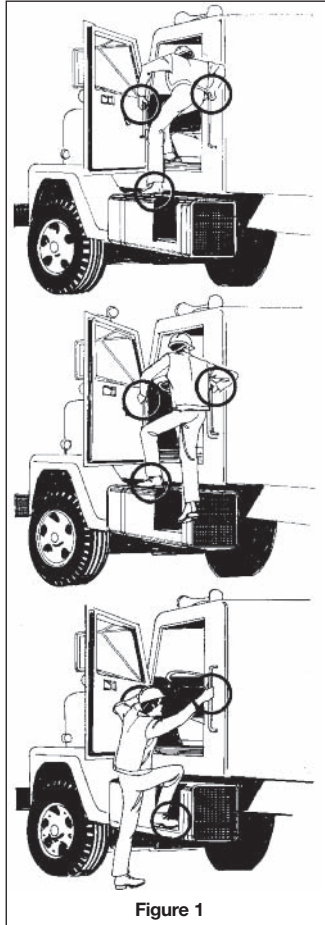


Figure 1

Remember

- ✓ always face in towards the machine or ladder
- ✓ mount and dismount only when the equipment is standing still
- ✓ break three-point contact only when you reach the ground, the cab of the vehicle, or a stable platform
- ✓ take your time
- ✓ take extra care in wet, snowy, icy, or other dangerous weather conditions
- ✓ avoid wearing loose or torn clothing that can catch on the equipment
- ✓ get on or off at the safest access position (normally designed by the manufacturer)
- ✓ where necessary, retrofit equipment to provide safe access.

The Construction Regulation states that construction equipment must have a means of access to the operator's station that will not endanger the operator, and must have skid-resistant walking, climbing, and work surfaces.

Ensure that your equipment complies with the law. And keep runningboards, treads, steps, footholds, and platforms clear of mud, ice, snow, grease, debris, and other hazards. Housekeeping keeps you and your co-workers safe!

31 TRENCHING

Contents

- Background
- Soil types
- Causes of cave-ins
- Protection against cave-ins
- Other hazards and safeguards
- Emergency procedures

Background

Fatalities

A significant number of deaths and injuries in sewer and watermain work are directly related to trenching.

Trenching fatalities are mainly caused by cave-ins. Death occurs by suffocation or crushing when a worker is buried by falling soil.

Over half of all powerline contacts involve buried cable. Before excavating, the gas, electrical, and other services in the area must be accurately located and marked. If the service poses a hazard, it must be shut off and disconnected.

Injuries

The following are the main causes of lost-time injuries in the sewer and watermain industry:

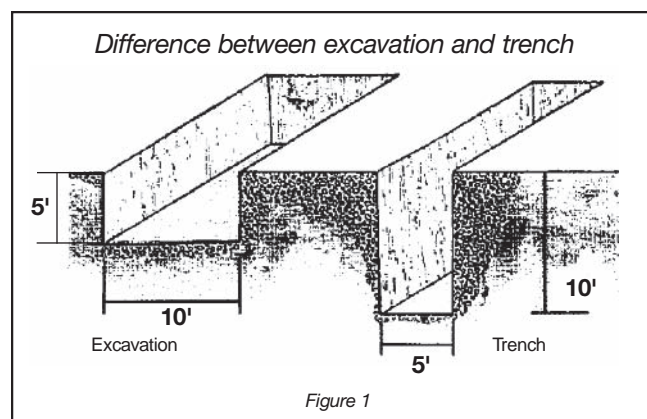
- material falling into the trench
- slips and falls as workers climb on and off equipment
- unloading pipe
- handling and placing frames and covers for manholes and catch basins
- handling and placing pipe and other materials
- being struck by moving equipment
- falls as workers climb in or out of an excavation

- falling over equipment or excavated material
- falling into the trench
- exposure to toxic, irritating, or flammable gases.

Many of these injuries are directly related to trenching.

Regulations

Supervisors and workers in the sewer and watermain industry must be familiar with the “Excavations” section of the Construction Regulation.



It is important to understand, for instance, the terms “trench” and “excavation.” An excavation is a hole left in the ground as the result of removing material. A trench is an excavation in which the depth exceeds the width (Figure 1).

The “Excavations” section of the Construction Regulation identifies the various types of soils and specifies the type of shoring and timbering to be used for each. It also spells out the requirements for trench support systems that must be designed by a professional engineer.

Soil types

The type of soil determines the strength and stability of trench walls.

Identifying soil types requires knowledge, skill, and experience. Even hard soil may contain faults in seams or layers that make it unstable when excavated.

The foreman or supervisor must be knowledgeable about soil types found on a project and plan protection accordingly. This knowledge must include an awareness that soil types and conditions can change over very short distances. It is not unusual for soil to change completely within 50 metres or for soil to become saturated with moisture over even smaller distances.

The Construction Regulation sets out four soil types.

Type 1 — It is hard to drive a pick into Type 1 soil. Hence, it is often described as “hard ground to dig”. In fact, the material is so hard, it is close to rock.

When excavated, the sides of the excavation appear smooth and shiny. The sides will remain vertical with no water released from the trench wall.

If exposed to sunlight for several days, the walls of Type 1 soil will lose their shiny appearance but remain intact without cracking and crumbling.

If exposed to rain or wet weather, Type 1 soil may break down along the edges of the excavation.

Typical Type 1 soils include “hardpan,” consolidated clay, and some glacial tills.

Type 2 — A pick can be driven into Type 2 soil relatively easily. It can easily be excavated by a backhoe or hand-excavated with some difficulty.

In Type 2 soil, the sides of a trench will remain vertical for a short period of time (perhaps several hours) with no apparent tension cracks. However, if the walls are left exposed to air and sunlight, tension cracks will appear as the soil starts to dry. The soil will begin cracking and splaying into the trench.

Typical Type 2 soils are silty clay and less dense tills.

Type 3 — Much of the Type 3 soil encountered in construction is previously excavated material. Type 3 soil can be excavated without difficulty using a hydraulic backhoe.

When dry, Type 3 soil will flow through fingers and form a conical pile on the ground. Dry Type 3 soil will not stand vertically and the sides of the excavation will cave in to a natural slope of about 1 to 1 depending on moisture.

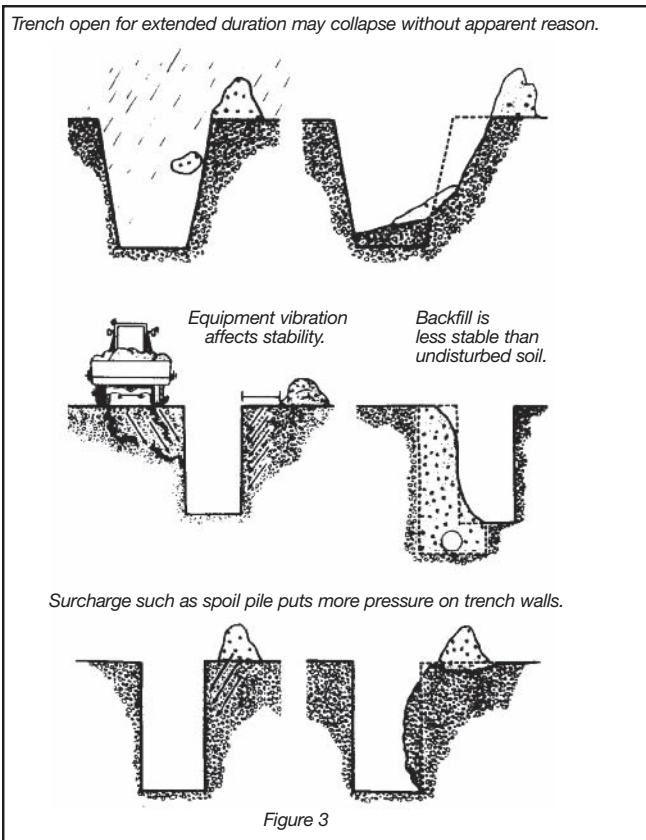
Wet Type 3 soil will yield water when vibrated by hand. When wet, this soil will stand vertically for a short period. It dries quickly, however, with the vibration during excavation causing chunks or solid slabs to slide into the trench.

All backfilled or previously disturbed material should be treated as Type 3. Other typical Type 3 soil includes sand, granular materials, and silty or wet clays.

Type 4 — Type 4 soil can be excavated with no difficulty using a hydraulic backhoe. The material will flow very easily and must be supported and contained to be excavated to any significant depth.

With its high moisture content, Type 4 soil is very sensitive to vibration and other disturbances which cause the material to flow.

Typical Type 4 material includes muskeg or other organic deposits with high moisture content, quicksand, silty clays with high moisture content, and leta clays. Leta clays are very sensitive to disturbance of any kind.



Many factors such as cracks, water, vibration, weather, and previous excavation can affect trench stability (Figure 2). Time is also a critical factor. Some trenches will remain open for a long period, then suddenly collapse for no apparent reason.

Figure 3 shows the typical causes of cave-ins.

The main factors affecting trench stability are soil type, moisture, vibration, surcharge, previous excavation, existing foundations, and weather.

Moisture content

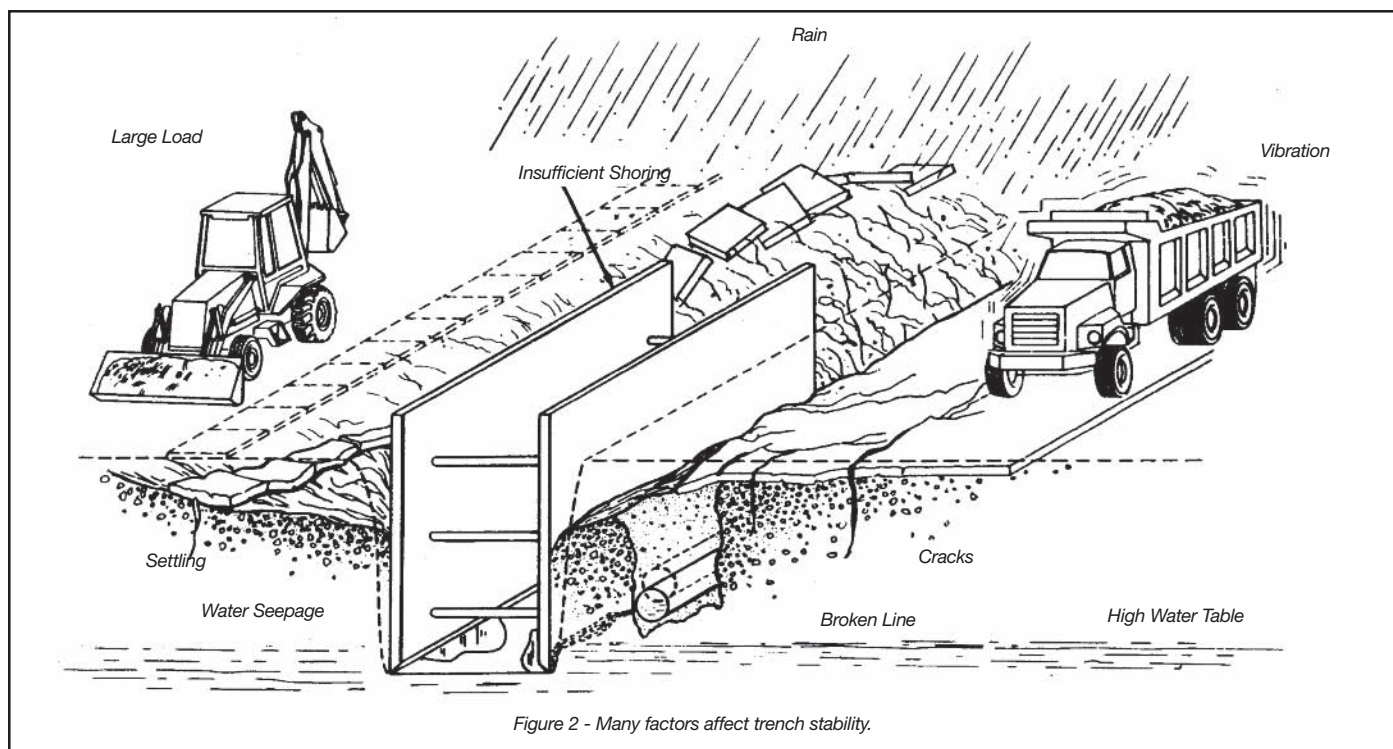
The amount of moisture in the soil has a great effect on soil strength.

Once a trench is dug, the sides of the open excavation are exposed to the air. Moisture content of the soil begins to change almost immediately and the strength of the walls may be affected.

The longer an excavation is open to the air, the greater the risk of a cave-in.

Causes of Cave-Ins

Soil properties often vary widely from the top to the bottom and along the length of a trench.



Vibration

Vibration from various sources can affect trench stability.

Often trench walls are subject to vibration from vehicular traffic or from construction operations such as earth moving, compaction, pile driving, and blasting. These can all contribute to the collapse of trench walls.

Surcharge

A surcharge is an excessive load or weight that can affect trench stability.

For instance, excavated soil piled next to the trench can exert pressure on the walls. Placement of spoil piles is therefore important. Spoil should be kept as far as is practical from the edge of the trench. Mobile equipment and other material stored close to the trench also add a surcharge that will affect trench stability.

One metre from the edge to the toe of the spoil pile is the minimum distance requirement (Figure 4). The distance should be greater for deeper trenches.

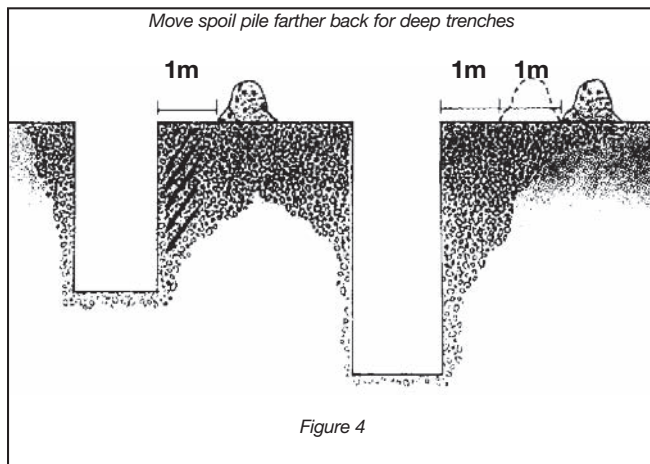


Figure 4

Previous excavation

Old utility trenches either crossing or running parallel to the new trench can affect the strength and stability (Figure 5).

Soil around and between these old excavations can be very unstable. At best it is considered Type 3 soil — loose, soft, and low in internal

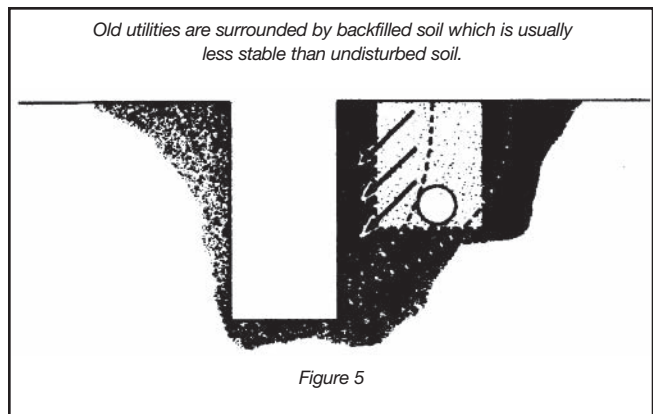


Figure 5

strength. In some unusual circumstances it may be Type 4 — wet, muddy, and unable to support itself.

This kind of soil will not stand up unless it is sloped or shored.

Existing foundations

Around most trenches and excavations there is a failure zone where surcharges, changes in soil condition, or other disruptions can cause collapse.

When the foundation of a building adjacent to the trench or excavation extends into this failure zone, the result can be a cave-in (Figure 6). Soil in this situation is usually considered Type 3.

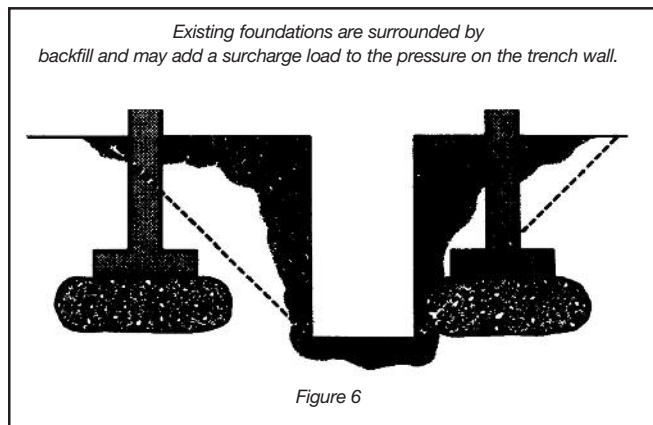
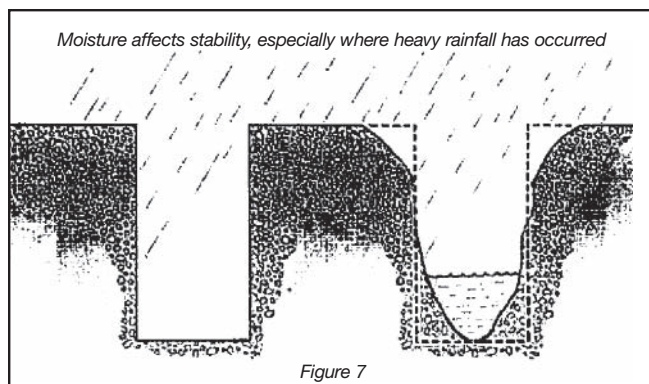


Figure 6

Weather

Rain, melting snow, thawing earth, and overflow from adjacent streams, storm drains, and sewers all produce changes in soil conditions. In fact, water from any source can reduce soil cohesion (Figure 7).



Frozen soil does not mean that you can have reduced shoring or that a heavier load can be supported. Frost extends to a limited depth only.

Protection Against Cave-Ins

There are three basic methods of protecting workers against trench cave-ins:

- sloping
- trench boxes
- shoring

Most fatal cave-ins occur on small jobs of short duration such as service connections and excavations for drains and wells. Too often people think that these jobs are not hazardous enough to require safeguards against collapse.

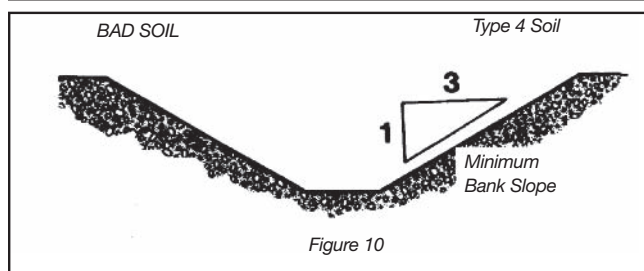
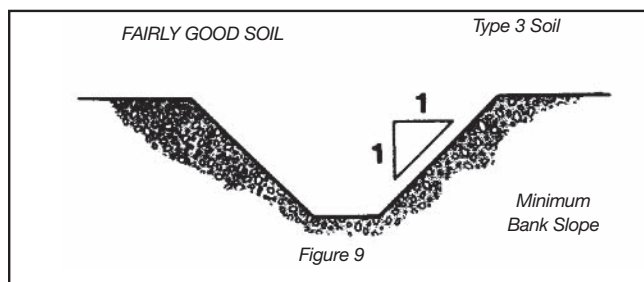
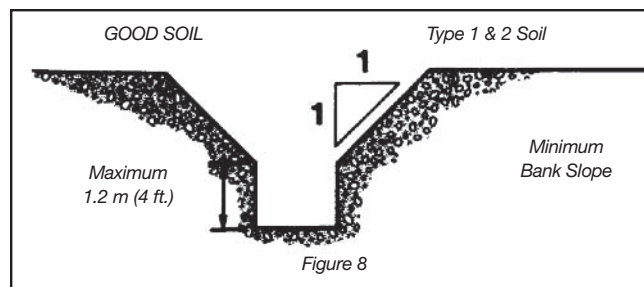
Unless the walls are solid rock, never enter a trench deeper than 1.2 metres (4 feet) if it is not properly sloped, shored, or protected by a trench box.

Sloping

One way to ensure that a trench will not collapse is to slope the walls.

Where space and other requirements permit sloping, the angle of slope depends on soil conditions (Figures 8, 9 and 10).

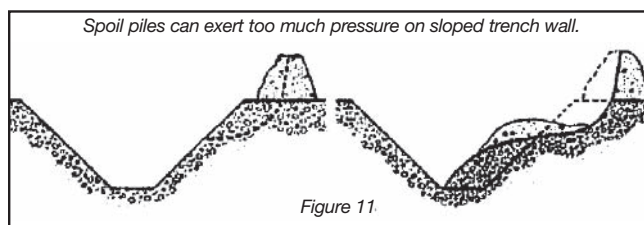
For Type 1 and 2 soils, cut trench walls back at an angle of 1 to 1 (45 degrees). That's one metre back for each metre up. Walls should be sloped to within 1.2 metres (4 feet) of the trench bottom (Figure 8).



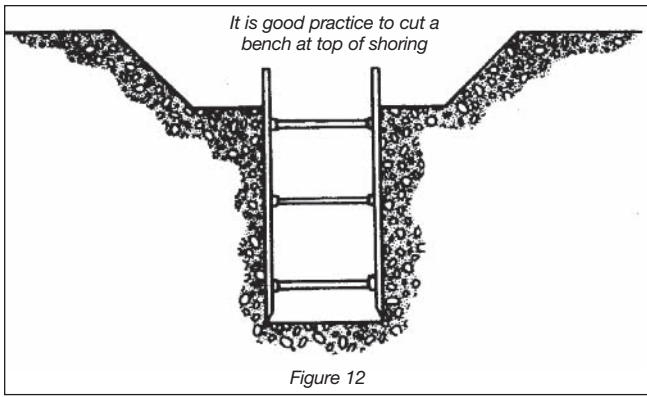
For Type 3 soil, cut walls back at a gradient of 1 to 1 from the trench bottom (Figure 9).

For Type 4 soil, slope the walls at 1 to 3. That's 3 metres back for every 1 metre up from the trench bottom (Figure 10).

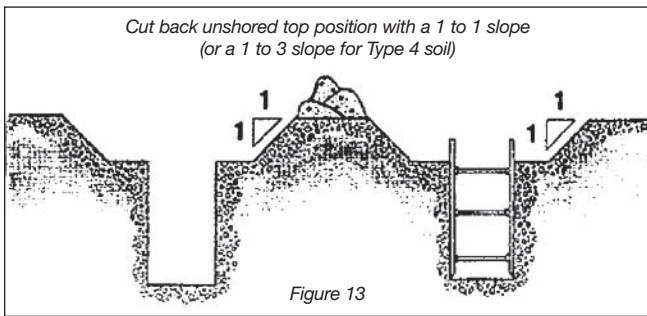
Although sloping can reduce the risk of a cave-in, the angle must be sufficient to prevent spoil not only from sliding back but also from exerting too much pressure on the trench wall (Figure 11).



Sloping is commonly used with shoring or trench boxes to cut back any soil above the protected zone. It is also good practice to cut a bench at the top of the shoring or trench (Figure 12).



If sloping is to be used above a trench box, the top portion of the cut should first be sloped 1 to 1 (or 1 to 3 for Type 4 soil — see previous page). Then the box should be lowered into the trench (Figure 13).



Trench boxes

Trench boxes are not usually intended to shore up or otherwise support trench walls. They are meant to protect workers in case of a cave-in.

Design drawings and specifications for trench boxes must be signed and sealed by the professional engineer who designed the system and must be kept on site by the constructor.

Boxes are normally placed in an excavated but unshored trench and used to protect personnel. A properly designed trench box is capable of withstanding the maximum lateral load expected at a given depth in a particular soil condition.

Trenches near utilities, streets, and buildings may require a shoring system.

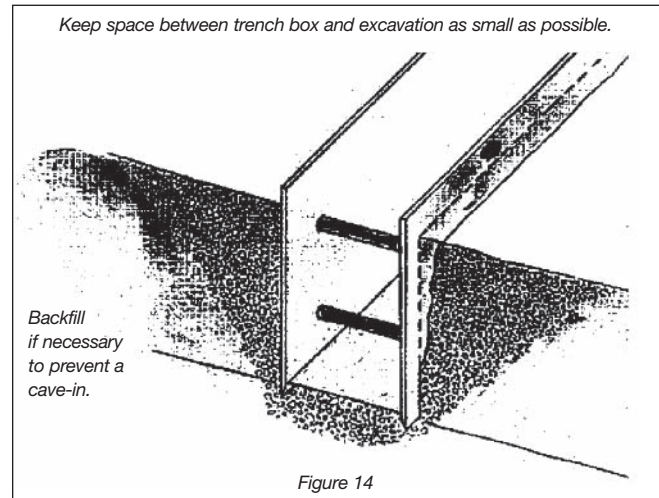
As long as workers are in the trench they should remain inside the box. Workers must not be inside the trench or the box when the box is being moved. A ladder must be set up in the trench box at all times.

Excavation should be done so that the space between the trench box and the excavation is minimized (Figure 14).

The two reasons for this are

- 1) allowing closer access to the top of the box
- 2) limiting soil movement in case of a cave-in.

Check the drawings and specifications for the trench box to see if the space between the box and the trench wall needs to be backfilled and the soil compacted.



Shoring

Shoring is a system which “shores” up or supports trench walls to prevent movement of soil, underground utilities, roadways, and foundations.

Shoring should not be confused with trench boxes. A trench box provides worker safety but gives little or no support to trench walls or existing structures such as foundations and manholes.

The two types of shoring most commonly used are timber and hydraulic. Both consist of posts, wales, struts, and sheathing.

Figures 15 and 16 identify components, dimensions, and other requirements for timber shoring in some typical trenches.

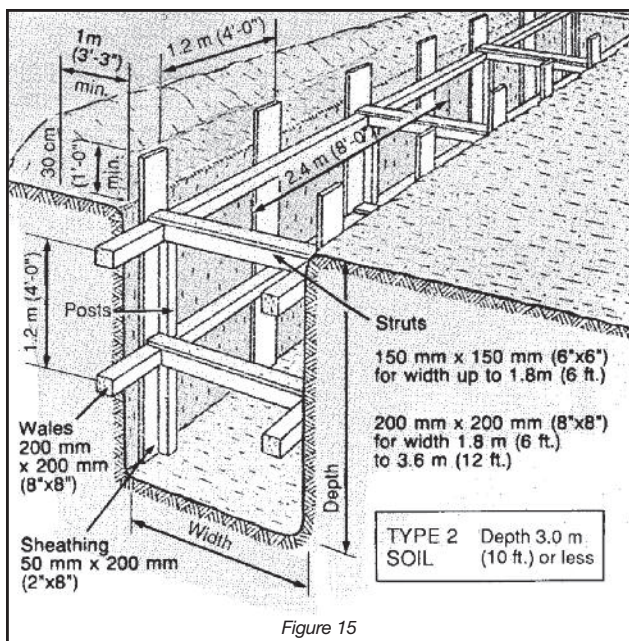


Figure 15

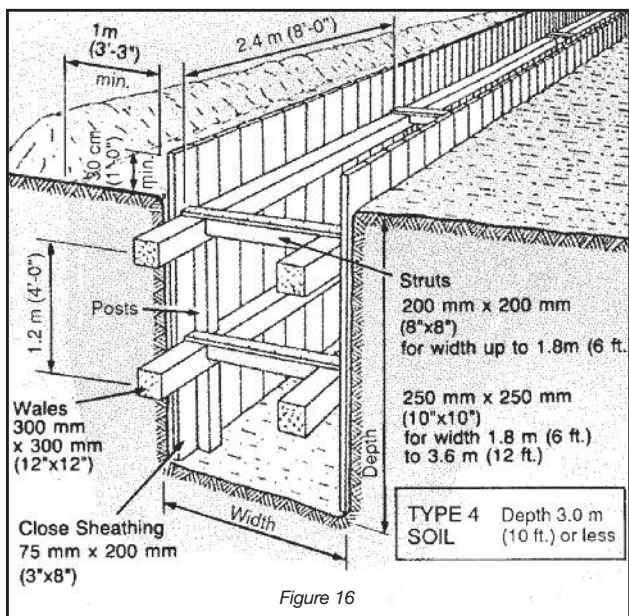


Figure 16

“Hydraulic shoring” refers to prefabricated strut and/or wale systems in aluminum or steel. Strictly speaking, these may not operate hydraulically. Some are air-operated or manually jacked. Design drawings and specifications for prefabricated shoring systems must be kept on site.

One major advantage of hydraulic shoring over some applications of timber shoring is safety during installation. Workers do not have to enter the trench to install the system. Installation can be done from the top of the trench.

Most hydraulic systems are

- light enough to be installed by one worker
- gauge-regulated to ensure even distribution of pressure along the trench line
- able to “pre-load” trench walls, thereby using the soil’s natural cohesion to prevent movement.
- easily adapted to suit various trench depths and widths.

Wherever possible, shoring should be installed as excavation proceeds. If there is a delay between digging and shoring, no one must be allowed to enter the unprotected trench.

All shoring should be installed from the top down and removed from the bottom up.

Access/egress

Whether protected by sloping, boxes, or shoring, trenches must be provided with ladders so that workers can enter and exit safely (Figure 17).

Ladders must

- be placed within the area protected by the shoring or trench box
- be securely tied off at the top
- extend above the shoring or box by at least 1 metre (3 feet)

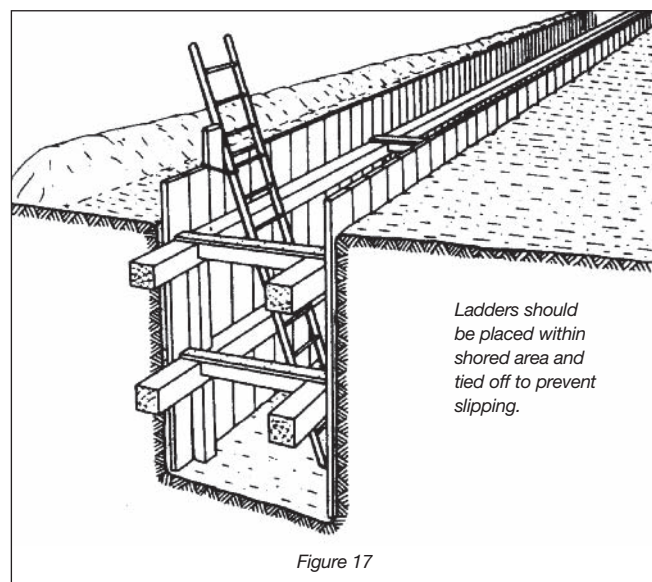


Figure 17

- be inspected regularly for damage.

Ladders should be placed as close as possible to the area where personnel are working and never more than 7.5 metres (25 feet) away.

Anyone climbing up or down must always face the ladder and maintain 3-point contact. This means that two hands and one foot or two feet and one hand must be on the ladder at all times.

Maintaining 3-point contact also means hands must be free for climbing. Tools and materials should not be carried up or down ladders. Pumps, small compactors, and other equipment should be lifted and lowered by methods that prevent injury from overexertion and falling objects.

Inspection

Inspection is everyone's responsibility. Whatever the protective system, it should be inspected regularly.

Check hydraulic shoring for leaks in hoses and cylinders, bent bases, broken or cracked nipples, and other damaged or defective parts (Figure 18).

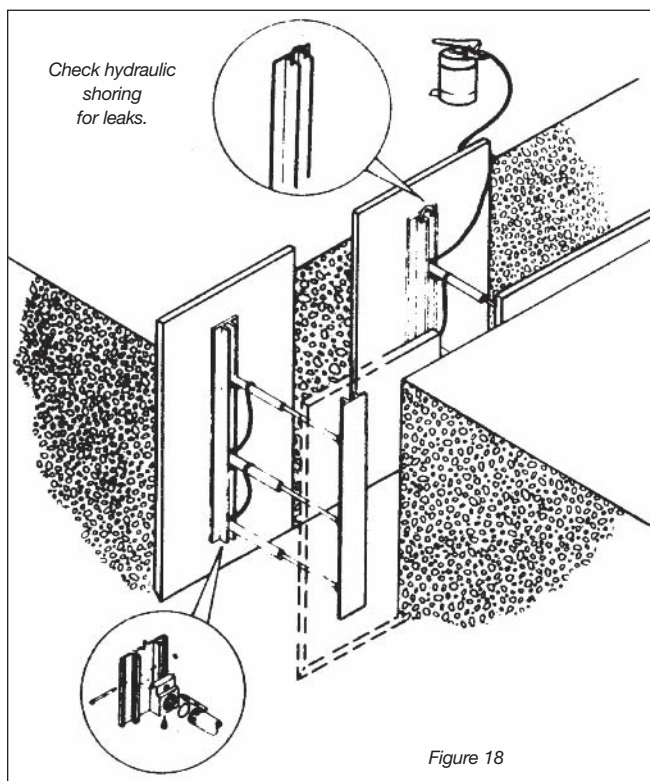


Figure 18

Check timber shoring before installation. Discard damaged or defective lumber. After installation, inspect wales for signs of crushing. Crushing indicates structural inadequacy and calls for more struts (Figure 19).

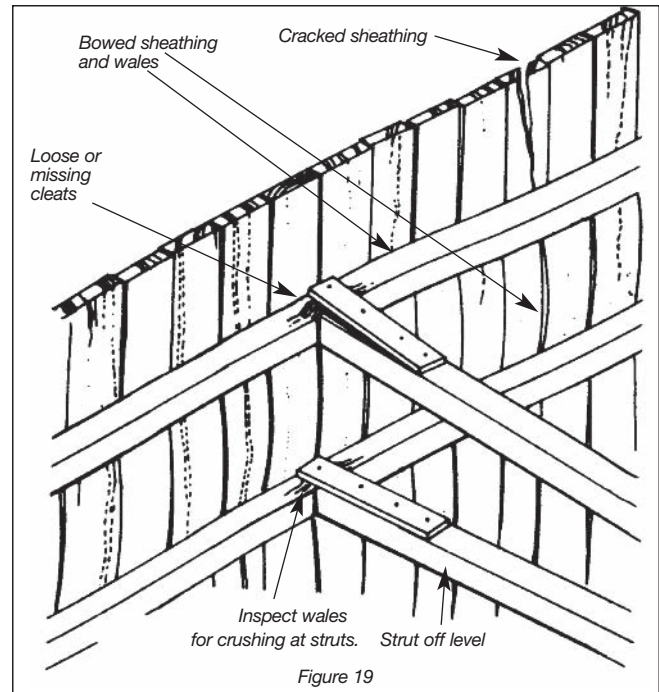


Figure 19

Inspect trench boxes for structural damage, cracks in welds, and other defects (Figure 20). During use, check the box regularly and often to make sure that it is not shifting or settling much more on one side than the other. If it is, leave the trench and ask the supervisor to check for stability.

Check ground surface for tension cracks which may develop parallel to the trench at a distance one-half to three-quarters of the trench depth (Figure 21). If cracks are detected, alert the crew and check all protective systems carefully.

Check areas adjacent to shoring where water may have entered the trench. A combination of water flow and granular soils can lead to undermining of the trench wall. Such conditions have caused fatalities.

Finally, make sure that tools, equipment, material, and spoil are kept at least 1 metre (3 feet) back from the edge of the trench to prevent falling objects from striking workers.

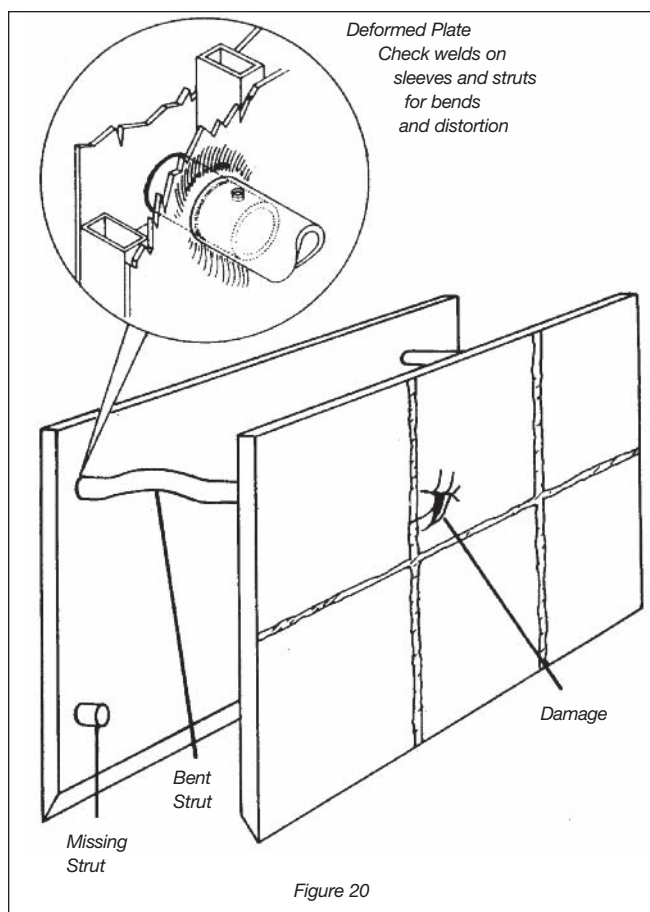


Figure 20

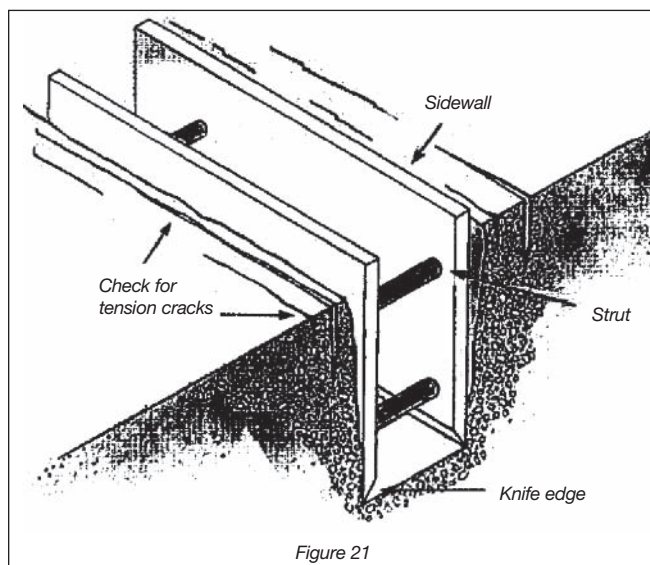


Figure 21

Summary

Sloping, trench boxes, and shoring are meant to protect workers from the hazards of cave-ins.

The method chosen must meet the specific requirements of the job at hand. Depending on application, one method may be better suited to certain conditions than another.

Whatever the system, inspect it regularly to make sure that it remains sound and reliable.

Remember: Never enter a trench more than 1.2 metres (4 feet) deep unless it is sloped, shored, or protected by a trench box.

Other Hazards and Safeguards

The risk of a cave-in is not the only hazard in trenching. Injuries and deaths are also related to six other major areas:

- personal protective equipment
- utilities underground and overhead
- materials handling and housekeeping
- heavy equipment
- traffic control
- confined spaces.

Personal protective equipment

Personal protective equipment is an important defence against certain types of injury.

Injuries from falling and flying objects, for instance, can be reduced by wearing hard hats and eye protection.

Everyone on a construction project must wear Grade 1 safety boots certified by the Canadian Standards Association (CSA) as indicated by the CSA logo on a green triangular patch (Figure 22).

Under the wet, muddy conditions often encountered in trenching, you may also require rubber safety boots displaying the same CSA logo on a green triangular patch.

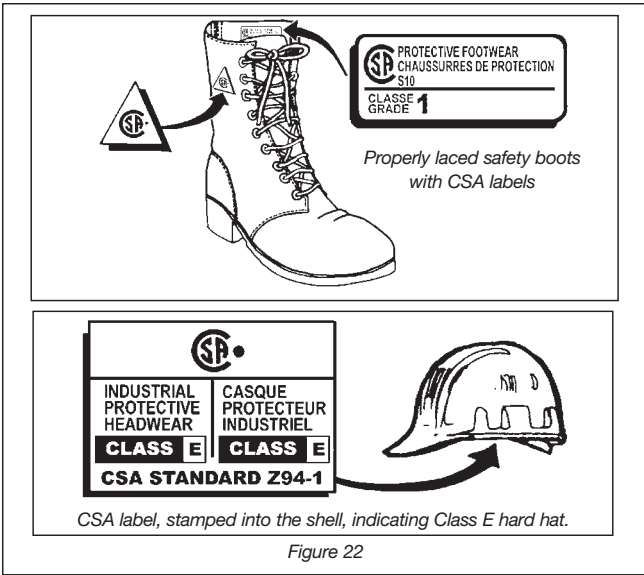


Figure 22

It is mandatory for everyone on a construction project to wear head protection in the form of a hard hat that complies with the current Construction Regulation.

Eye protection is strongly recommended to prevent injuries from construction operations such as chipping and drilling and site conditions such as dust.

Personnel exposed for long periods to noisy equipment should wear hearing protection.

Work in confined spaces such as manholes and valve chambers may require respiratory protection against hazardous atmospheres.

See the chapters on personal protective equipment in this manual for more information.

Underground utilities

Locates — Services such as gas, electrical, telephone, and water lines must be located by the utility before excavation begins.

The contractor responsible for the work must contact the owners of any underground utilities that may be in that location or phone Ontario One Call. Request locates for all the underground utilities in the area where excavation will be taking place.

The service locate provided by the utility owner should indicate, using labelled stakes, flags, and/or paint marks, the centre line of the underground utility in the vicinity of the proposed excavation.

The excavator should not work outside of the area covered by the locate stakeout information without obtaining an additional stakeout.

Locate stakeout accuracy should be considered to be 1 metre on either side of the surface centre line locate unless the locate instructions specifically indicate other boundary limits.

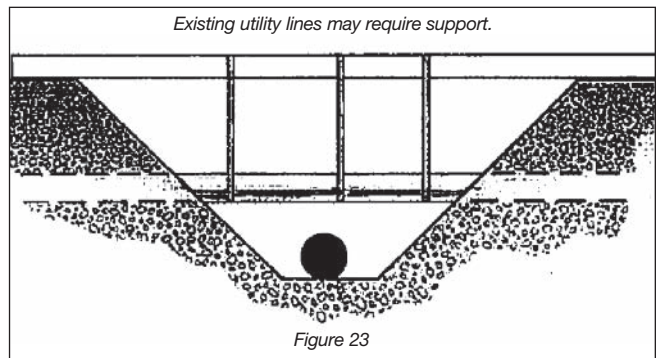
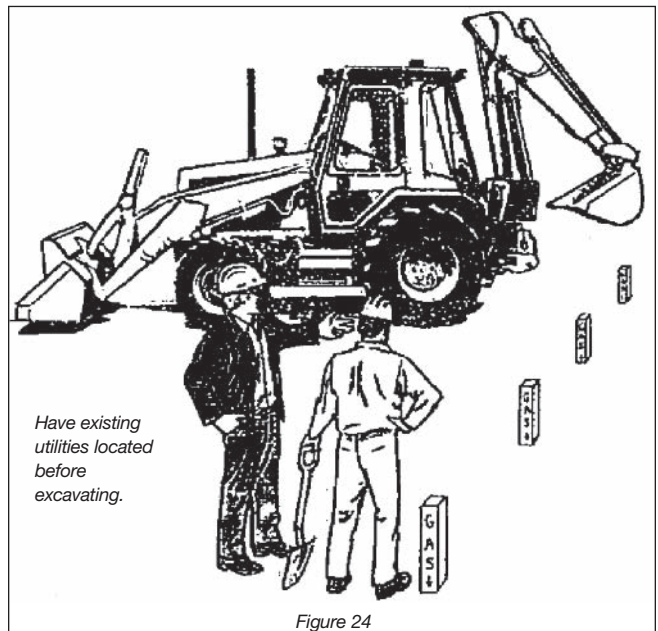


Figure 23

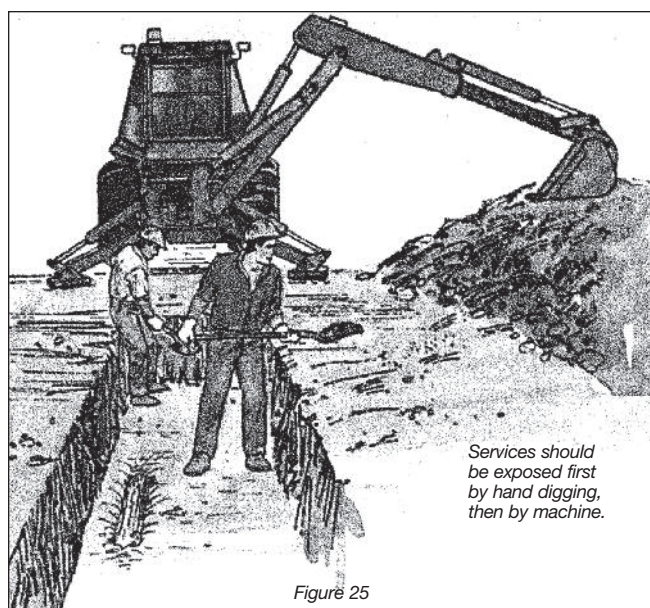
Where the underground utility cannot be located within the locate stakeout limits, the utility owner should be contacted to assist with the locate.

Mechanical excavation equipment should not be used within the boundary limits of the locate



Have existing utilities located before excavating.

Figure 24



without first digging a hole or holes using the procedure below to determine the underground utility's exact centre line and elevation.

Test holes should, in general, be excavated by one of the following methods:

- (a) machine excavation immediately outside the boundary limits and then hand digging laterally until the underground utility is found; or
- (b) (i) hand excavation perpendicular to the centre line of the locate in cuts of at least 1 foot in depth;
 - (ii) mechanical equipment can then be used carefully to widen the hand-dug trench to within one foot of the depth of the hand-dug excavation;
 - (iii) repeat steps (i) and (ii) until the utility is located; or
- (c) a hydro-excavation system — acceptable to the owner of the utility — which uses high-pressure water to break up the cover material and a vacuum system to remove it can be used to locate the underground utility.

Centre line locates should be provided and test holes dug where a representative of the utility identifies

- (a) alignment changes
- (b) changes in elevation.

Where an underground utility may need support or where it may shift because of disturbance of surrounding soil due to excavation, guidelines for excavation and support should be obtained from the owner of the utility (Figure 23).

Breaks — Breaks in electrical, gas, and water services can cause serious injuries, even deaths. Hitting an underground electrical line can result in electrocution, while hitting a gas line can cause an explosion. A broken water line can release a sudden rush of water, washing out support systems and causing a cave-in.

Cutting telephone lines can create a serious problem if emergency calls for police, fire, or ambulance are required.

In the event of gas line contact, call the gas company immediately. The company will check the line and close down the supply if necessary.

If a leak is suspected, people in the immediate area should be told to evacuate. Where service to a building or home has been struck, people inside should be advised to leave doors and windows open; shut off appliances, furnaces, and other sources of ignition; and vacate the premises until the gas company declares it safe to return.

Construction personnel should take two precautions.

- 1) Put out smoking materials and shut off other sources of ignition such as engines and equipment.
- 2) Leave the trench immediately. Gas can collect there.

Overhead powerlines

When equipment operates within reach of (and could therefore encroach on) the minimum permitted distance from a live overhead powerline,

the constructor must have written procedures in place to prevent the equipment from encroaching on the minimum distance.

Voltage Rating of Powerline	Minimum Distance
750 or more volts, but not more than 150,000 volts	3 metres (10')
more than 150,000 but not more than 250,000 volts	4.5 metres (15')
more than 250,000 volts	6 metres (20')

If equipment touches a high-voltage line, the operator should take the following precautions.

- 1) Stay on the machine. Don't touch equipment and ground at same time. Touching anything in contact with the ground could be fatal.
- 2) Anyone operating accessory equipment should also remain on that equipment. They should also avoid making contact with the ground and the equipment at the same time.
- 3) Keep others away. Warn them not to touch the load, load lines, boom, bucket, or any other part of the equipment (Figure 26).
- 4) Get someone to call the local utility to shut off power.

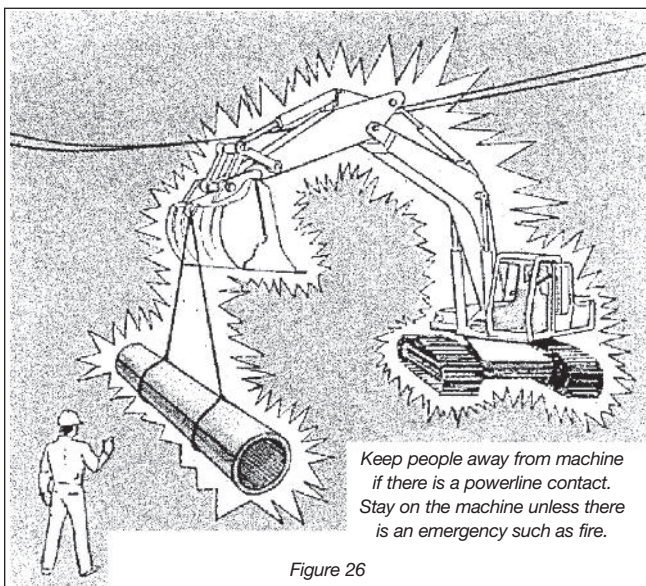


Figure 26

- 5) If possible, the operator (while remaining on the machine) can try to break contact by moving the machine clear of the wires.

Warning: Beware of time relays. Even after breakers are tripped by line damage, relays may be triggered to restore power.

- 6) If the operator can't break contact by moving the machine (while remaining on it), do not move the machine until the utility shuts down the line and confirms that power is off.
- 7) If an emergency such as fire forces you to leave the machine, jump clear (Figure 27). Never step down. If part of your body contacts the ground while another part touches the machine, current will travel through you.
- 8) Jump with feet together and shuffle away in small steps. Don't take big steps. With voltage differential across the ground, one foot may be in a higher voltage area than the other. The difference can kill you (Figure 28).

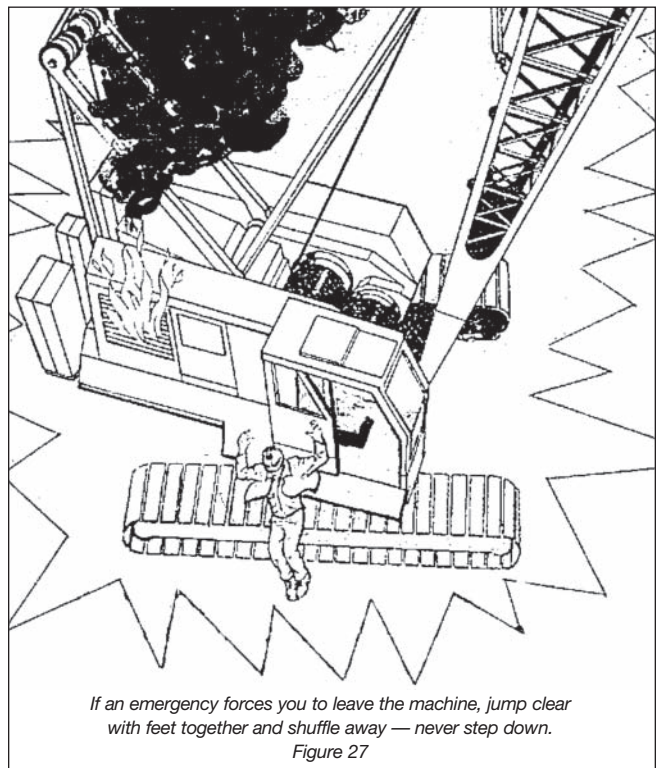
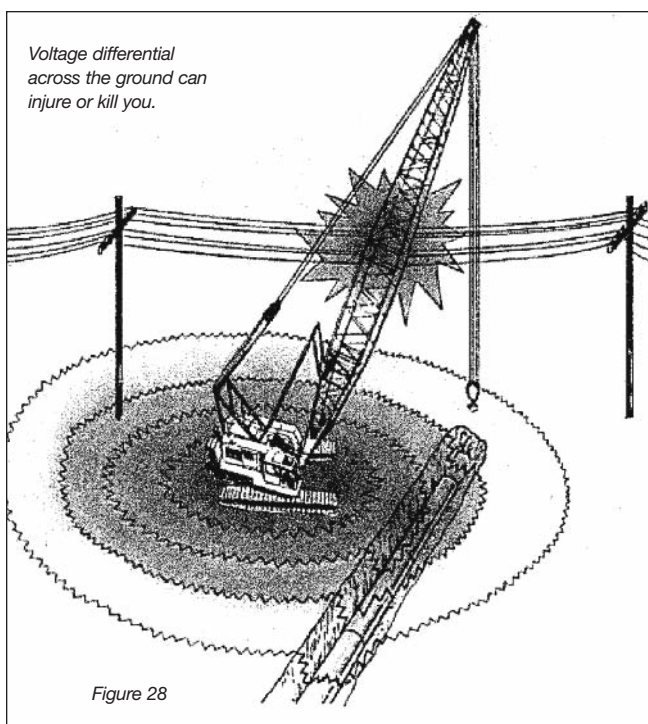


Figure 27



Special precautions are required for casualties in contact with live powerlines or equipment.

- 1) Never touch the casualty or anything in contact with the casualty.
- 2) If possible, break contact. Use a dry board, rubber hose, or dry polypropylene rope to move either the casualty or the line. An object can sometimes be thrown to separate the casualty from the wire.

Warning : Touching the casualty, even with dry wood or rubber, can be dangerous. With high voltage lines, objects that are normally insulators can become conductors.

- 3) Call emergency services — in most cases ambulance, fire department, and utility.
- 4) Provide first aid once the casualty is free of contact. If the casualty is not breathing, begin artificial respiration immediately (mouth-to-mouth is most efficient) or CPR. Apply cold water to burns and cover with clean dressing.

Materials handling

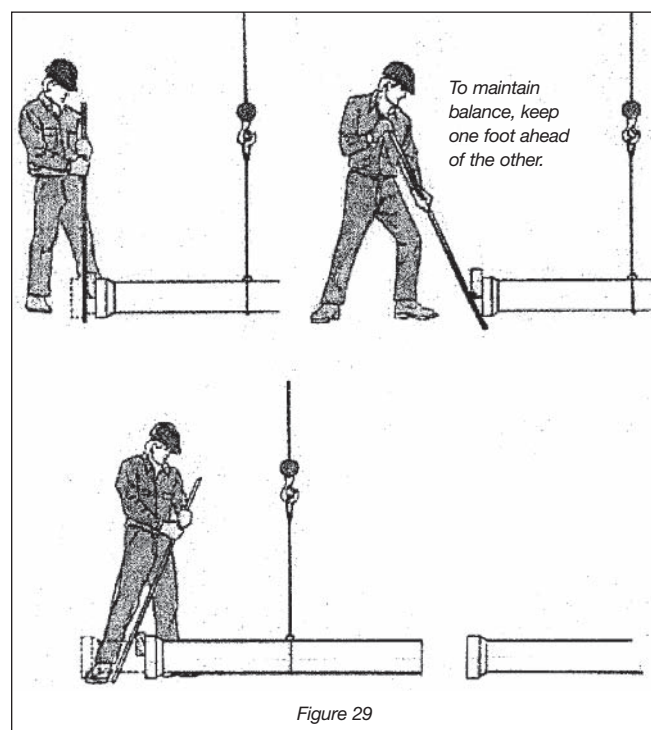
Many lost-time injuries in trenching involve materials handling. Moving rock and soil, lifting pipe and manhole sections, laying down bedding material, or lowering pumps and compactors into the trench can all be hazardous.

Pipe — Trucks should always be on level ground when pipe is unloaded. Pipe should be chocked or staked before tie-downs are released. These measures will reduce the risk of sections rolling off the truck.

Plastic and small diameter pipe is often banded with metal straps. Be careful cutting the straps. They are under tension and can fly back and hit you.

Personnel often injure fingers and hands when laying and joining sections of pipe. While sections are suspended from hoisting equipment, keep hands away from slings or chokers in tension. When guiding and pushing sections together by hand, never curl fingers around ends or flanges.

As pipe is placed along the trench, each section should be blocked or set so that it cannot roll and cause injury.



Back injuries can occur when small-diameter pipe is being hoisted into position (Figure 29). The worker pushing the bar should place his feet directly in front of the pipe with one foot ahead of the other.

Large-diameter pipe should be placed with pipe pullers (Figure 30).

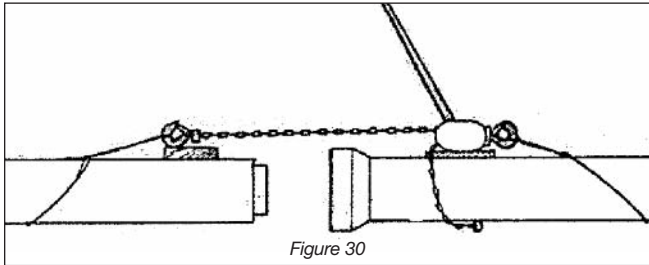


Figure 30

Bedding material — Personnel shovelling bedding material in the trench are usually working in a confined area where footing is muddy and uneven.

The result can be overexertion or slips and falls leading to back and other injuries. Mechanical equipment can significantly reduce this hazard. For instance, bedding material can be put in the excavator bucket with a front-end loader, then spread evenly along the trench bottom.

Rigging — Rigging is essential to safe, efficient materials handling since pipe, manhole sections, and equipment are lowered into the trench by cranes or other hoisting devices.

Rigging these loads properly can prevent injury.

Inspect slings and rigging hardware regularly and replace any damaged or worn devices.

With **nylon web slings**, damage is usually easy to spot: cuts, holes, tears, worn or distorted fittings, frayed material, broken stitching, heat burns. Damaged web slings should be replaced.

When using **wire rope slings**, inspect for broken wires, worn or cracked fittings, loose seizings and splices, flatening, and corrosion. Knots or kinks indicate that wire rope slings are permanently damaged and should not be used.

Damage most often occurs around thimbles and fittings. Don't leave wire rope lying on the

ground for any length of time in damp or wet conditions.

Eyes in wire rope slings should be fitted with thimbles. To make an eye with clips, put the U-bolt section on the dead or short end of the rope and the saddle on the live or long end (Figure 31).

Remember — never saddle a dead horse.

At least three clips are required for wire rope up to 5/8" diameter, and four are required for wire rope greater than 5/8" up to and including 7/8" diameter.

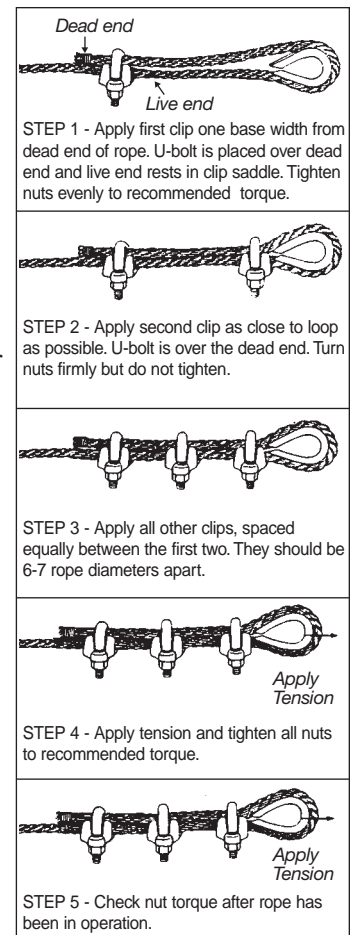


Figure 31

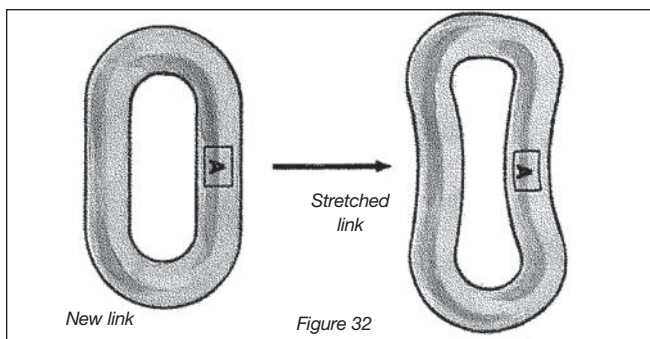
Avoid binding the eye section of wire rope slings around corners. The bend will weaken the splice or swaging.

When using choker hitches, do not force the eye down towards the load once tension is applied.

When using **chain slings**, inspect for elongated links. A badly stretched link tends to close up (Figure 32).

Look for bent, twisted, or damaged links that can result when chain has been used to lift a load with unprotected sharp edges.

Inspect for cracks. Although sometimes hard to detect, cracks always indicate that the chain should be removed from service. Also look for gouges, chips, cuts, dents, peen marks, and corrosive wear at points where links bear on each other.



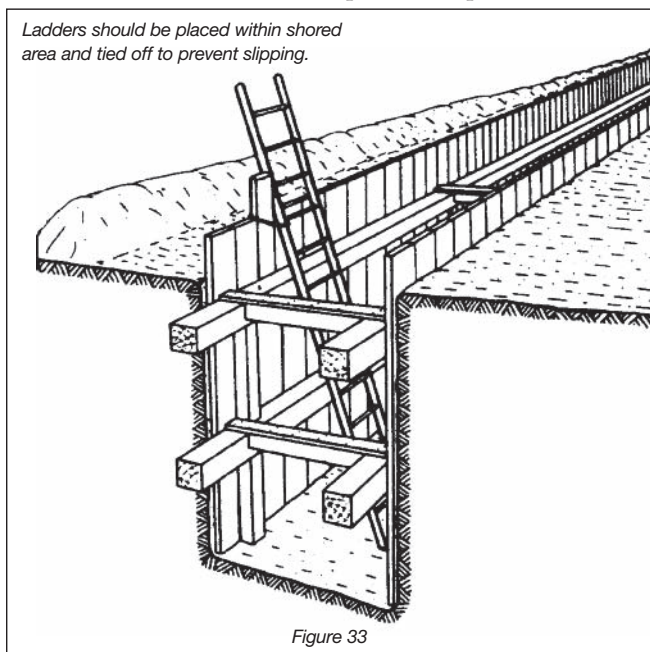
Rigging Tips

- Wherever possible, lower loads on adequate blockage to prevent damage to slings.
- Keep hands away from pinch points when slack is being taken up.
- Stand clear while the load is being lifted and lowered or when slings are being pulled out from under it.
- Use tag lines to control swinging, swaying, or other unwanted movement of the load.

Housekeeping

Accident prevention depends on proper housekeeping at ground level and in the trench.

At the top of the trench, sections of pipe, unused tools and timber, piles of spoil, and



other material must be kept at least 1 metre (3 feet) away from the edge.






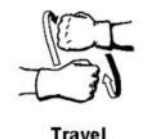


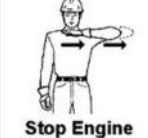



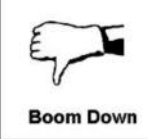
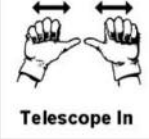
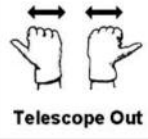
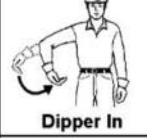

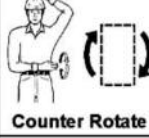
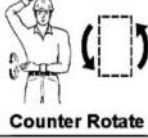



The slips and falls common on excavation projects can be reduced by cleaning up scrap and debris. Trenches should also be kept as dry as possible. Pumps may be required.

Proper housekeeping is especially important around ladders. The base and foot of the ladder should be free of garbage and puddles. Ladders should be tied off at the top, placed in protected areas, and inspected regularly for damage (Figure 33).

Heavy equipment

Excavators, backhoes, and other heavy equipment can cause injuries and fatalities to operators and personnel on foot.

Excavator handsignals — Communicate clearly with your co-workers. Use the following handsignals.

 Load Up	 Load Down	 Swing Left	 Swing Right
 Turn Left	 Turn Right	 Travel	 This Far To Go
 Everything Slow	 Stop Engine	 Stop	 Emergency Stop
 Boom Up	 Boom Down	 Telescope In	 Telescope Out
 Dipper In	 Dipper Out	 Counter Rotate	 Counter Rotate
 Open Bucket	 Close Bucket	 Dog Everything	NO RESPONSE SHOULD BE MADE TO UNCLEAR SIGNALS

Operators — Improperly climbing on and off equipment has caused injuries to operators for many years. The best prevention is to maintain 3-point contact (Figure 34).

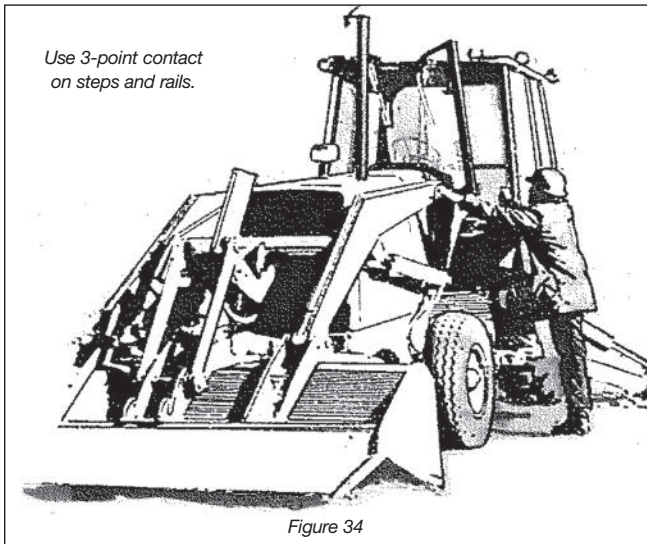


Figure 34

Equipment should be fitted with steps, grabs, and rails that are repaired or replaced when damaged.

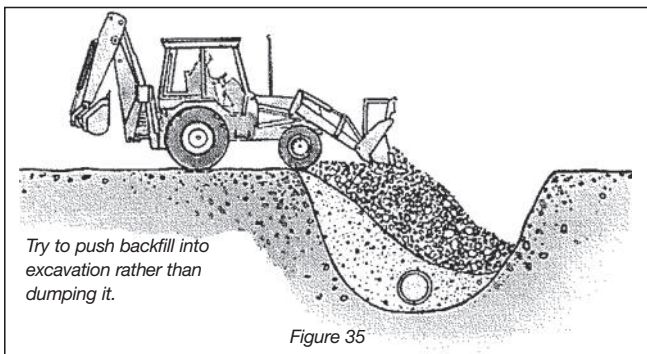


Figure 35

Operators have also suffered serious injuries when equipment upsets because of soil failure near excavations (Figure 35), improper loading on floats, or inadvertently backing into excavations.

Moving equipment — Signallers are required by law

- if the operator's view of the intended path of travel is obstructed, or
- if a person could be endangered by the moving equipment or its load.

Back-up alarms are required on dump trucks

and recommended for all moving equipment. Where vehicles have to operate in reverse, warning signs must be conspicuously posted.

Ground rules for truck drivers

- Understand and obey the signaller at all times.
- Remain in the cab where possible.
- Ensure that mirrors are clean, functional, and properly adjusted.
- Do a circle check after being away from the truck for any length of time (walk around the truck to ensure the area is clear before moving).
- Stop immediately when a signaller, worker, or anyone else disappears from view.

Workers on foot — Personnel on foot are frequently stuck by machine attachments such as excavator buckets and bulldozer blades when they stand or work too close to operating equipment, especially during unloading and excavation.

Workers on foot are also injured and killed by equipment backing up.

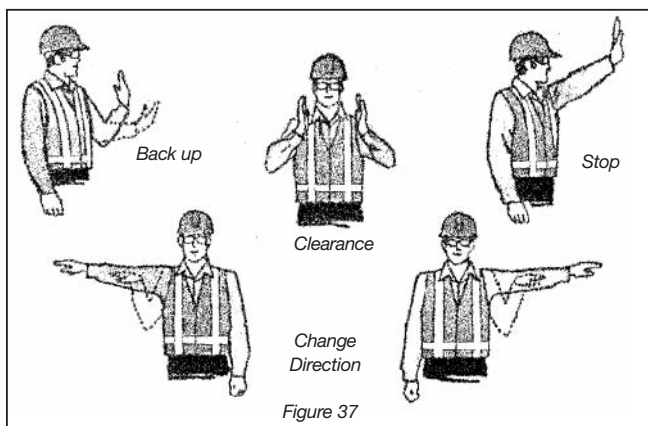
Ground rules for workers on foot

- Beware of common operator blind spots. See chapter on Backing Up in this manual.
- Stay alert to the location of equipment around you.
- Avoid entering or standing in blind spots.
- **Always remain visible to the operator. Make eye contact to ensure that you are seen.**
- Never stand behind a backing vehicle.
- Remember — the operator may be able to see you while you are standing but not when you kneel down or bend over.

Signallers — In heavily travelled or congested work areas, a signaller may be necessary to direct equipment and prevent injuries and deaths caused by vehicles backing up.

Ground rules for signallers

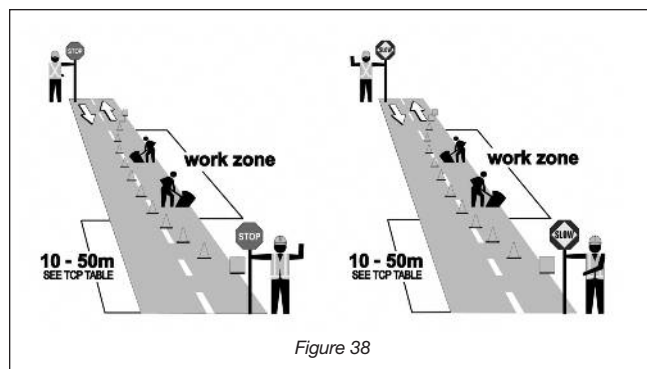
- Wear a fluorescent or bright orange safety vest.
- Use standard hand signals (Figure 37).
- Stand where you can see and be seen.
- Stay in full view of the operator and the intended path of travel.
- Know where the operator's blind spots are.
- Warn other workers to stay clear of equipment.



Traffic control

On trenching projects along public roadways, the construction crew must be protected from traffic. Regulations specify the following methods for protecting personnel:

- traffic control persons (TCPs) using signs (Figure 38)
- warning signs
- barriers
- lane control devices
- flashing lights or flares.



Supervisors must train TCPs on site and explain the nature of the project, where construction equipment will be operating, and how public traffic will flow. TCPs must wear a fluorescent or bright orange safety vest.

Training must also include the proper use of the STOP/SLOW sign, where to stand, how to signal, and communication with other TCPs. (See chapter on Traffic Control in this manual.)

After presenting this information, the supervisors must give TCPs written instructions in a language they can understand.

Confined spaces

A confined space is defined as a place

- a) that is **partially or fully enclosed**
- b) that is not both designed and constructed for **continuous human occupancy**, and
- c) where **atmospheric hazards** may occur because of its construction, location, or contents, or because of work that is done in it.

All three criteria have to be met before a space is defined as a confined space.

In the sewer and watermain industry, confined spaces can be locations such as excavations, manholes, valve chambers, pump stations, and catch basins. The atmosphere in these spaces may be

- toxic
- oxygen-deficient

- oxygen-enriched
- explosive.

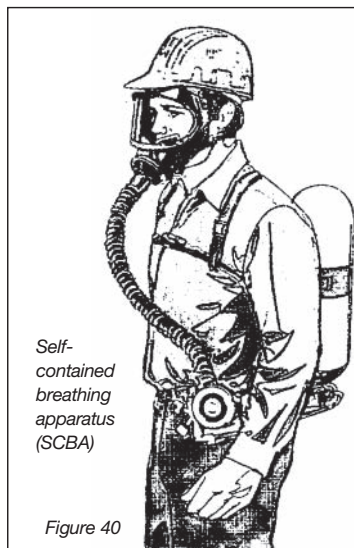
Sewage not only smells bad but can create dangerous atmospheres. Decaying waste releases hazardous gases such as hydrogen sulfide and methane. The bacteria in sewage are not only a source of infection but can also consume oxygen and leave the atmosphere oxygen-deficient.

Other sources of contamination can include

- fumes from welding or patching compounds
- chemicals from waste disposal sites
- engine exhaust
- propane or other explosive gases that are heavier than air and collect in the bottom of the trench
- leaks from underground storage tanks
- decomposing material in landfill sites.

Protecting the health and safety of personnel starts with some basic steps.

- A competent worker must test a confined space to determine whether it is hazard-free before a worker enters, and continue testing to ensure that it remains hazard-free.
- Where tests indicate safe air quality, workers may be allowed to enter the confined space.
- Where tests indicate a hazardous level of fumes, vapours, gases, or oxygen,



entry must not be allowed until the space has been adequately ventilated and subsequent tests indicate that the air is safe to breathe.

- Where possible, mechanical venting should be continued in any confined space containing hazardous levels of fumes, vapours, gases, or oxygen, even after venting has corrected the hazard. The space must also be continuously monitored while personnel are working there.
- In situations where ventilation has removed a hazard, workers entering the space should still wear rescue harnesses attached to individual lifelines. A worker should also be posted at the entrance prepared, equipped, and trained to provide rescue in an emergency. For rescue situations, workers entering the space should wear supplied-air respirators (Figure 40).

For more information on confined spaces and controls, see the chapter on Confined Spaces in this manual.

Hydrostatic testing

Hydrostatic testing involves entry into a confined space such as a manhole or valve chamber. The procedures listed above should be followed.

Testing new lines can be very hazardous if components break or plugs let go. For that reason, additional precautions are required.

When testing watermains, ensure that all lines, elbows, and valves are supported and equipped with thrust blocks. Otherwise the line could come apart under test pressure.

Arrange watermain testing so that lines are pressurized when no one is in the manhole or valve chamber.

For sewer line testing, all requirements for entering confined spaces apply.

Ensure that plugs are secure. No one should be in a manhole when the upstream line is being filled. Plugs that are not properly installed can let go, causing injury and letting a manhole fill quickly, depending on the size of the line.

Flooding is another reason why no one should be in a manhole without a rescue harness and a worker outside ready and prepared for an emergency.

Emergency Procedures

General

Emergency telephone numbers — ambulance, fire, police, local utilities, senior management, Ministry of Labour — should be posted in the field office for quick reference.

If someone is seriously injured, take the following steps.

- 1) Protect the area from hazards.
- 2) Prevent further injury to the casualty.
- 3) Administer first aid.
- 4) Call an ambulance or rescue unit.
- 5) Have someone direct the ambulance or rescue unit to the accident scene.

All projects must have a person qualified and certified to provide first aid.

Cave-ins

It is natural to try to rescue casualties caught or buried by a cave-in. But care must be taken to prevent injury and death to rescuers, whether from a further cave-in or other hazards.

The following procedures may be suitable, depending on conditions.

- 1) To get down to the casualty, use a tarpaulin, fencing, plywood, or similar material that can cover the ground and will ride up over any further cave-in.
- 2) Sometimes a further cave-in can be

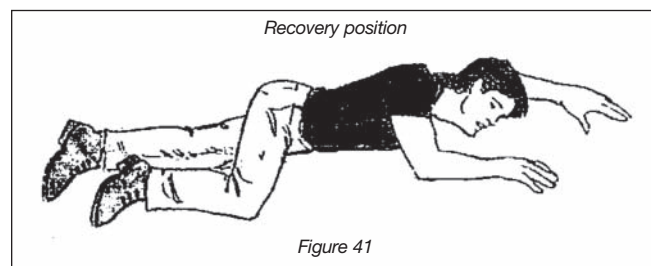
prevented by placing a backhoe bucket against the suspected area or excavating it.

- 3) Rescue workers should enter the trench with ropes and wear rescue harnesses if possible.
- 4) To prevent further injury, remove the casualty by stretcher whenever possible. Tarps or ladders can be used as a makeshift stretcher.
- 5) Stabilize the casualty.

Breathing — Ensure that the casualty is breathing. If not, open the airway and start artificial respiration immediately. Mouth-to-mouth is the most efficient method.

Bleeding — Control external bleeding by applying direct pressure, placing the casualty in a comfortable position, and elevating the injured part if possible.

Unconsciousness — This is a priority because it may lead to breathing problems. An unconscious person may suffocate when left lying face up. If injuries permit, unconscious persons who must be left unattended should be placed in the recovery position (Figure 41).



32 PROPANE

INTRODUCTION

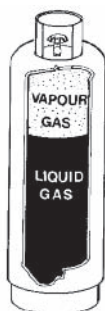
Packaged under pressure, propane gas presents three hazards if misused:

1. high flammability and explosive potential
2. displacement of breathable air in confined spaces (also, being heavier than air, propane will collect in low areas)
3. contact injury from accidental exposure to a substance under high pressure.

We will not cover the use of propane in the roofing industry.

Propane - Physical Characteristics

Propane or liquefied petroleum gas (LPG) is a by-product of petroleum or natural gas refining which is packaged under pressure in cylinders. In its stored state it is a liquid but is released from the cylinder or tank in a gaseous form. The boiling point of propane, the point at which the liquid converts to a gas, is -42.2°C (-44°F). If the surrounding air temperature is above this, gas will form in the upper part of the cylinder (Figure 1).



Cutaway view of vapour withdrawal propane cylinder
Figure 1

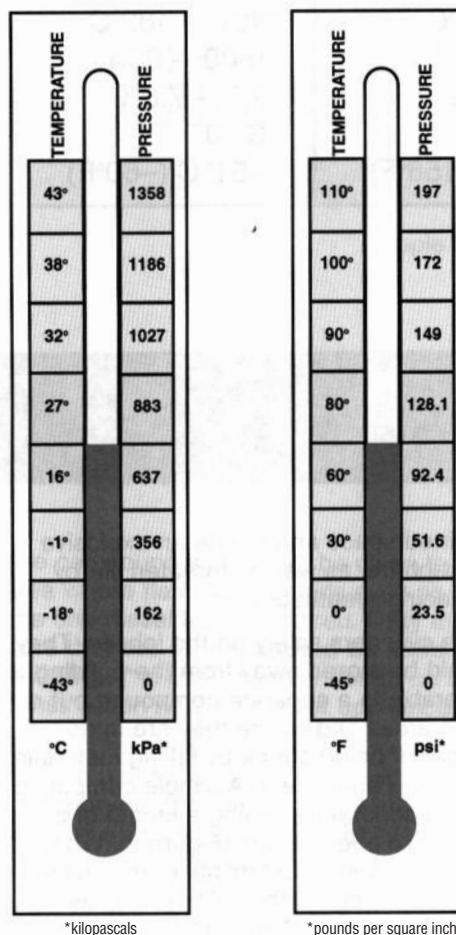
The pressure within the container is variable depending on the temperature to which the container is exposed (Table 1). The pressure increases as the temperature rises, causing expansion of the liquid. For this reason containers are never fully charged with liquid, but have a vapour space at the top of the tank to allow for normal expansion.

Should the temperature rise above safe limits, a relief valve will open to allow release of the gas in a measured amount. This release is generally over in seconds. The valve reseals and remains closed until the pressure builds up again. Cylinder relief valves are set at 2585.5 kPa (375 lb per square inch).

Propane is packaged in a number of cylinder types and sizes to meet a variety of applications:

- 100-lb cylinders for construction heaters, roofing kettles, and other appliances that consume large amounts of fuel. They are called 100 lb cylinders because they are charged with 100 lb of liquid at the propane plant.
- 20-lb cylinders for oxypropane welding set-ups. (This is a familiar size that will be used on such appliances as household gas barbecues.)
- 10 and 20 lb cylinders for soldering work.
- 14 oz. throwaway containers for various hand-held torch applications.

Propane can be easily compressed from a gaseous to a liquid state in small cylinders, making it very portable. When the liquid converts back to a gas, it expands 270 times in volume. Compared to natural gas, propane has a



Temperature/Pressure Variables (values taken from CSA Standard B149.2-M80)
Table 1

heating value that is 2.5 times greater. One cubic foot of propane converts to 2500 BTUs, while one cubic foot of natural gas converts to only 1000 BTUs. This explains why so much energy (BTUs) can be contained in a small cylinder, making it a very convenient fuel for the contractor.

But the high-energy value of propane also makes it very dangerous to handle. It only takes a tiny leak to form an explosive gas/air mixture.

The high flammability of propane can be seen by comparing its ignition characteristics with those of gasoline (Table 2).

	Propane	Gasoline
Minimum ignition temperature range	493° - 549°C (920° - 1020°F)	427° - 482°C (800° - 900°F)
Flammability limits in air	2.4 - 9.5%	1.3 - 7.5%
Vapour density (air=1)	1.52	3.50
Minimum flash point	-104°C (-156°F)	-51°C (-60°F)

Table 2

When you consider that the heat from a lighted cigarette ranges between 1000°F and 1600°F, and that a lighted match produces 2000°F, all that is necessary for combustion is a sufficient quantity of propane gas mixed with air. This is why safety procedures must be followed so that a very efficient energy source does not become a hazard to workers.

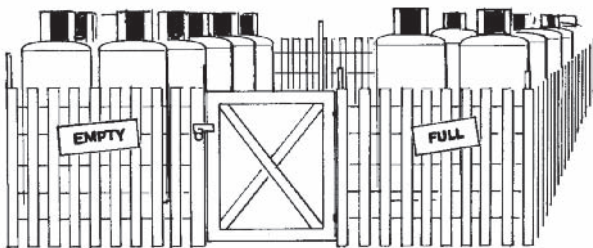
Safe Handling of Cylinders

In construction, most propane applications dispense the fuel in a vapour form. For this reason it is essential that portable cylinders be transported, stored, and used in an upright position. Propane liquid must never come in contact with the cylinder relief valve. If liquid escapes through the valve, large volumes of gas will be released. On a construction heater, for example, this can cause a serious overburn with flames extending many feet past the burner tip.

The simplest way to avoid the problem is to fasten cylinders in an upright position with rope, wire, or other means. When transporting by truck, take extra care to keep cylinders upright and stationary. Cylinders should not be transported in an automobile trunk or in a closed van. Because propane is heavier than air, escaping gas can collect in a confined space and create an explosive atmosphere, as well as threaten life by displacing breathable air.

Store cylinders safely on the jobsite. They should be stored away from buildings, preferably in a separate compound out of traffic areas and where they are in no danger of being struck by falling materials or moving equipment. A simple compound can be constructed using a length of snow fence and a few T-bars (Figure 2). When properly constructed, this barrier provides a means of tying up the cylinders as well as controlling stock. Cylinders should not be stored closer than 25 feet to a property line. Empty cylinders should be stored on one side, full on the other. Don't mix the cylinders.

The compound should not be close to an area where flammable liquids such as gasoline and diesel fuel are stored. **Only cylinders that are in use should be inside a building.** ("In use" means hooked up to a construction heater or other appliance.)



Simple but secure on-site storage
Figure 2

Propane must not be stored inside a building unless in a specially constructed explosion-proof room, which meets the propane and fire codes. Do not locate cylinders in stairwells and hallways. Leaking gas or the outbreak of fire can block exits and prevent escape.

When moving cylinders of gas around the jobsite, remember the following precautions.

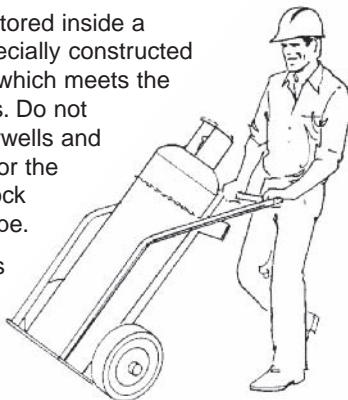


Figure 3

- Keep cylinders upright. Use a hand cart (Figure 3). Never roll cylinders.
- Use a hoisting cradle to move cylinders from one level to another (Figure 4).
- Never use a sling. This practice is prohibited by the Construction Regulation under the *Occupational Health and Safety Act*.
- Never hook onto the protective collar around the valve.
- Keep cylinders away from heat sources.

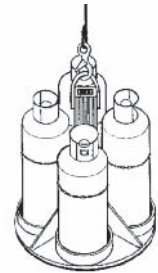


Figure 4

Heaters

You must have a record of training (ROT) recognized by the Technical Standards and Safety Authority (TSSA) before you can hook up and light a propane-fired heater.

When hooking up and using construction heaters, observe the following precautions.

- All connections must be made by a competent worker.
- Inspect burner, controls, regulator, and hose for defects. Have any damaged parts repaired or replaced. **Gas-burning equipment should only be repaired by licensed service personnel.**
- Make sure all hose and valve connections are clean.
- Use fitting wrenches to make connections. Don't use adjustable pipe wrenches.

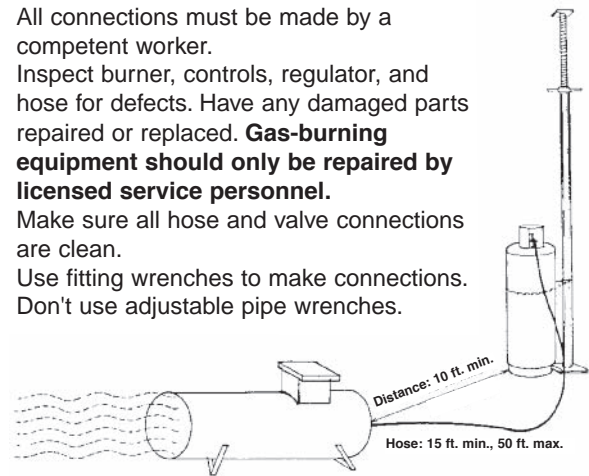


Figure 5

Secure the cylinder and keep it at least 10 feet away from the heater. Hose length must be between 15 feet and 50 feet.

- Cylinders should be at least 10 feet away from the heaters. The cylinder should be placed well clear of any heat source and never at the flame end of a heater.
- Have a 4A40BC fire extinguisher on hand before lighting the heater.
- When connections are made, slowly open the cylinder valve and check for leaks when the hose line is full of gas. Cylinder valves in use must be fully opened. Check for leaks with soapy water (Figure 6) or a leak detector. Sometimes you may notice a gas odour or frost appearing on a fitting, but these signs are not always reliable. If a leak is detected, shut off the cylinder valve and make corrections. Fully close valves when not in use.
- If the cylinder valve is opened too quickly it may

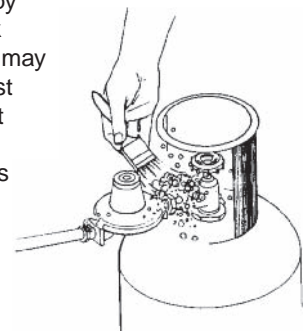
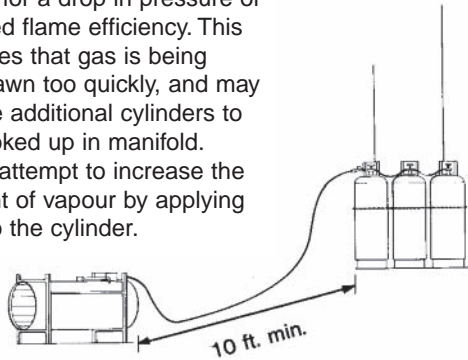


Figure 6 - Soap Test for Leaks

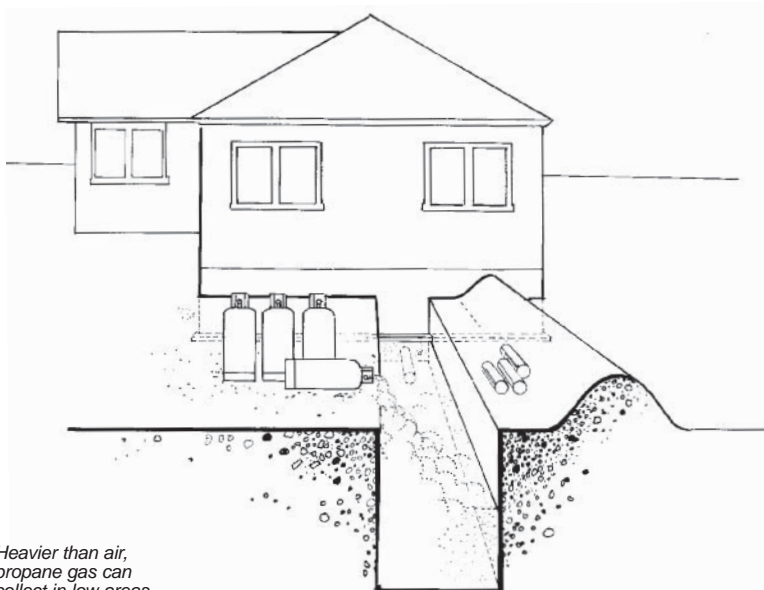
cause closing (slugging) of the excess flow check valve. The purpose of this valve is to shut off gas flow should the regulator accidentally be broken off.

- To unslug the check valve, shut off the flow at the cylinder, wait a couple of minutes for the check valve to reopen, then proceed. The cylinder valve should be opened slowly to its normal limit, approximately 1-1/2 to 2 turns. Do not force the valve beyond this limit.
 - Secure the cylinder by tying or wiring it to a column or other upright. Keep cylinders out of traffic areas where they may be knocked over.
 - Cylinder and heater must always be in the same room so that the cylinder valve can be shut down quickly if trouble develops.
 - Keep heaters away from flammable materials. The heat from a burner is effective well past the tip.
 - Watch for a drop in pressure or reduced flame efficiency. This indicates that gas is being withdrawn too quickly, and may require additional cylinders to be hooked up in manifold.
- Never attempt to increase the amount of vapour by applying heat to the cylinder.



Typical Manifold Set-Up
Figure 7

- Where possible, use only single cylinders for heaters. However, if cylinders must be manifolded, use no more than three 100-pound cylinders (Figure 7). If other heaters with manifolded cylinders are to be operated in the same area, they must be at least fifty feet away or be separated by a firewall.
- Remember that propane is heavier than air and will collect in low areas such as trenches, pits, and



Heavier than air, propane gas can collect in low areas and create the potential for asphyxiation or explosion.

Figure 8

basements where it can create a flammable or explosive situation (Figure 8).

- Never attempt to tie down, defeat, or bypass safety devices on a construction heater. If the heater is defective, replace it. If the heater is inadequate, get extra heaters or replace it with a larger one.
- If the flame goes out, act with caution. Shut off the gas supply, then determine whether escaped gas is concentrated in the area. Because of its strong odour, you can usually smell propane. However, in a confined space, test with a gas detection device. If escaped gas is detected or even suspected, ventilate and purge the area thoroughly before relighting the unit.

Warning - If the heater is in a confined or low-lying area, escaped gas can be hazardous. Never enter the area without help standing by. Never attempt to relight until the gas is completely purged from the area.

- Never expose any part of your skin to liquid propane. Propane under pressure is extremely cold and can cause frostbite. Always wear gloves when handling cylinders.
- Don't allow propane gas to saturate your clothing. A highly flammable situation can remain for some time after the exposure. Saturated clothing should be removed and aired outside.
- Never operate heaters without adequate ventilation. Follow manufacturer's recommendations on the plate.

Bulk Tanks

Propane construction heaters that operate from a central bulk storage tank are common on large construction projects. This type of installation takes planning and close consultation between contractor and gas supplier to select a safe, convenient tank storage area that will not interfere with on-site traffic and materials handling, nor infringe on property line clearance requirements. The bulk

tank and feed lines are installed by licensed service personnel, but hooking up the heaters is generally left to workers on the site. The feed lines are usually well provided with hook-up points called station valves. They consist of a shut-off and a connection point for a flexible hose. However, the same rules for hooking up to a portable container apply here.

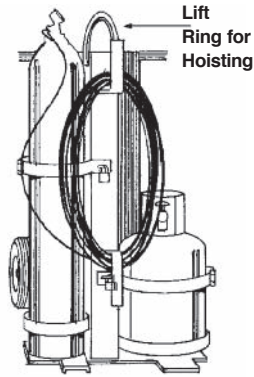
- Check for leaks at the hook-up point after installing flexible heater line.
- Make sure the shut-off valve is in the same room as the heater.
- If heat is required in an area that is not serviced by a valve a qualified service person should extend the line, or take off a spur line using approved piping and install a valve at its terminus.
- Flexible hose lengths should never exceed 25 feet between heater and station valve.

Welding and Cutting

In recent years, propane has become a popular energy source in open flame welding and cutting. Combined with oxygen in a manner similar to oxyacetylene welding, it provides a gas mix that is considered much more stable by many users.

While welding cylinders are generally smaller than cylinders used for construction heaters, they should be treated with the same care.

- Fittings should be clean and free of grease before hooking up.
- Fitting wrenches should be used to avoid damage to parts.
- Cylinders should be in an upright position at all times, kept in a suitable cradle when in use, and preferably tied upright to prevent tipping over (Figure 9).
- A fire extinguisher (4A40BC minimum) should be kept close when using any torch.
- Regulators should be removed and stored in a protective case when not in use, along with hoses and torches.
- Consult manufacturer's handbook for oxypropane regulator settings. They are very different from oxyacetylene settings. For more information, refer to **Welding and Cutting** in this manual.



Oxypropane Welding Cart
Figure 9



Summary

The safe use of propane depends on twelve basic rules:

- 1) Don't store cylinders inside a building.
- 2) Remove cylinders from the building when not in use or when empty.
- 3) Keep cylinders away from heat sources, and flammables away from heaters.
- 4) Always secure cylinders to prevent upset.
- 5) Never transport cylinders in an enclosed vehicle or trunk.
- 6) Always use proper gear for hoisting or moving cylinders around the worksite.
- 7) Keep heaters in good condition. Repairs and maintenance should be done only by licensed service personnel.
- 8) Always have a fire extinguisher handy (4A40BC minimum).
- 9) Protect stored cylinders or bulk tanks from on-site traffic.
- 10) Don't tamper with controls or safety devices.
- 11) Never enter an area where leaking gas is suspected.
- 12) Don't use or store cylinders of propane in low areas such as trenches, maintenance holes, or basements.

33 CONFINED SPACES

Complies with changes to the Construction Regulation (Ontario Reg. 213/91) implemented in 2006.

Before letting a worker enter a confined space, the employer must develop a written confined space program meeting the requirements of the Construction Regulation (Part II.1, Confined Spaces, sections 221.1 to 221.19). The employer must maintain the program.

CONFINED SPACE PROGRAM

Among the first requirements for employers developing a confined space program is the need to assess which workers will be entering the confined space and therefore which workers will need a copy of the confined space program.

Employers must provide a copy of the program to the constructor of a project. In turn, the constructor must provide a copy of the program to the project's joint health and safety committee or health and safety representative, if any. A copy must also be available to other employers to which the program relates and every worker if there is no project joint health and safety committee or health and safety representative.

If workers from more than one employer will be entering the confined space, the constructor must prepare a **confined space coordination program**. A copy of the confined space coordination document must be provided to each employer who is performing work in the confined space and to the project's joint health and safety committee or the health and safety representative.

The confined space program can apply to one or more confined spaces.

Program elements must include

- a method of recognizing each confined space
- a method for assessing the hazards to which workers may be exposed
- a method for developing plans for controlling the hazards
- a method for training workers
- an entry permit system setting out measures and procedures to be followed when working in a confined space.

Coordination

When workers of more than one employer perform work in the same confined space the constructor must prepare a coordination document to ensure that the various employers perform their duties in a way that protects the health and safety of all workers. A copy of the coordination document must be provided to

- each employer of workers who perform work in the same confined space
- the project's joint health and safety committee or health and safety representative.

RECOGNIZING A CONFINED SPACE

A confined space is defined as a place

- a) that is **partially or fully enclosed**
- b) that is not both designed and constructed for **continuous human occupancy**, and
- c) where **atmospheric hazards** may occur because of its construction, location, or contents, or because of work that is done in it.

All three criteria have to be met before a space is defined as a confined space. Here is more information on each of the criteria.

Partially or fully enclosed

Because air cannot move freely in and out of a partially or fully enclosed space, there is a potential for a hazardous atmosphere to be generated inside. This is especially true for spaces such as vaults, tanks, pits, trenches, or manholes.

Not designed and constructed for continuous human occupancy

Confined spaces are not designed or constructed for people to work in them on an ongoing basis. They are usually designed and constructed to store material, transport products, or enclose a process. But occasionally, some work must be done inside the space.

Atmospheric hazards

A hazardous atmosphere is one which contains any of the following:

- an accumulation of flammable, combustible, or explosive agents
- less than 19.5% or more than 23% oxygen, or
- an accumulation of atmospheric contaminants that could result in **acute** (short-term) health effects which
 - a) pose an immediate threat to life, or
 - b) interfere with a person's ability to escape unaided from a confined space.

HAZARD ASSESSMENT

Before each time that a worker enters a confined space, a **competent worker** must perform a written hazard assessment. The name of the competent worker must appear on the assessment and the employer must keep a record of the competent worker's qualifications.

The hazard assessment must take into account

- a) the hazards that may exist in the confined space
- b) the hazards that may develop while work is performed inside the confined space
- c) general safety hazards in the confined space.

The competent worker must sign and date the assessment and give it to the employer.

If requested, the employer must give copies of the assessment and competent worker's qualifications to

- the project's joint health and safety committee, or
- the health and safety representative, or
- every worker involved in the confined space entry if the project has no joint health and safety committee or health and safety representative.

COMPETENT WORKER

in relation to specific work, means a worker who

- a) is qualified because of knowledge, training and experience to perform the work
- b) is familiar with the *Occupational Health and Safety Act* and the provisions of the regulations that apply to the work, and
- c) has knowledge of all potential or actual danger to health and safety in the work.

The employer must review the assessment as often as necessary to make sure that the plans remain adequate. For example, if the potential chemical hazard changes due to a change in process or equipment use, then the assessment must be changed.

An assessment is generally required for each confined space. But if there are two or more similar confined spaces containing the same hazards then you need only a single assessment document.

To perform a hazard assessment, you need to anticipate potential hazards. Often, the hazards of working in confined spaces are not recognized until it's too late.

For example:

- A mixing tank was inadvertently started while a worker was inside.
- A worker was killed by carbon monoxide gas from a gasoline-powered pump used to drain a pit.

Because construction projects are not limited to new buildings, confined spaces may be encountered in a variety of places. The following table describes typical confined spaces and the most common hazards found there.

Hazards in confined spaces can be divided into two distinct categories: physical hazards and atmospheric hazards.

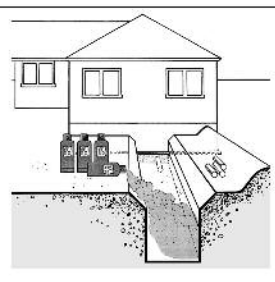
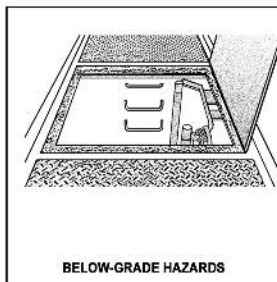
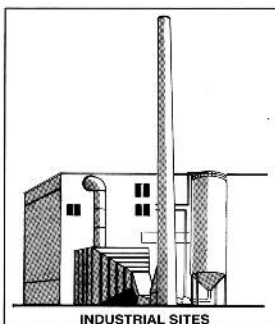
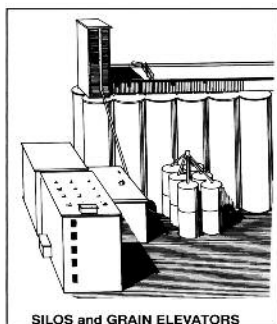
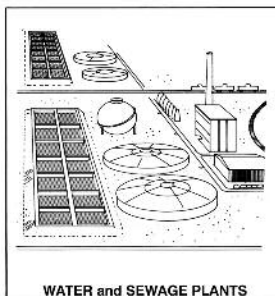
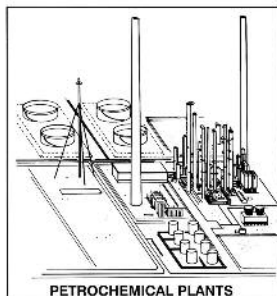
If control measures (such as continuous mechanical ventilation) are used to ensure that the concentrations of an atmospheric hazard are **controlled** or maintained at an appropriate level (but not eliminated) then the space would still be considered a confined space. If, however, measures are implemented to **eliminate** the possibility that any atmospheric hazards may occur in a space, then the confined space provisions no longer need to apply.

Eliminating the possibility that an atmospheric hazard will occur is different from controlling the hazard. If workers must enter the confined space to eliminate the hazards (by steam-cleaning or vacuuming, for example), then the confined spaces provisions apply.

EVERY CONFINED SPACE MUST BE THOROUGHLY ASSESSED AND EVALUATED BY A COMPETENT WORKER TO DETERMINE WHETHER IT IS POSSIBLE TO ELIMINATE THE ATMOSPHERIC HAZARD COMPLETELY.

Even if a space is not defined as a confined space under the regulations, the employer must take every precaution

TYPICAL LOCATIONS OF CONFINED SPACES



PHYSICAL HAZARDS

Physical hazards often present a greater danger inside an enclosed space than they do outside.

Examples:

► **Noise and vibration**

An enclosed environment can amplify noise. Excessive noise can damage hearing and prevent communication. It can affect workers' ability to hear alarms, warning shouts, or orders to evacuate.

► **Temperature extremes**

Ask plant personnel if workers could encounter dangerous temperatures. For example, heat stress can be a hazard when working around boilers, hot pipe or tanks, or structures heated by the sun. Protective clothing can also add to heat stress.

► **Cramped work spaces**

Cramped work spaces restrict movement and can make using tools and equipment difficult and dangerous.

► **Poor access or exit**

Confined space openings are generally small and not well-located. This can make entry and exit difficult and can interfere with rescue.

► **Rotating or moving equipment**

Before entry, identify any moving or rotating equipment (such as conveyors, mixers, augers, etc.) which could become activated by stored pressure, accidental contact,

Examples of confined spaces	Common hazards
<p>Chemical and petrochemical projects Tanks, vessels, storage tanks, underground tanks, pipes, sumps, pits, any area where a worker cannot readily escape from a toxic or explosive atmosphere; any area where toxic, explosive, or oxygen deficient atmospheres may be encountered.</p>	<p>Toxic and explosive gases, vapours and fumes; physical hazards of cramped entry and exit, narrow passages, and chemical spills.</p>
<p>Sewage handling systems Settling tanks, sewers, manholes, pumping areas, septic tanks, digesters.</p>	<p>Toxic and/or explosive atmospheres such as hydrogen sulphide and methane; oxygen deficiencies.</p>
<p>Water treatment plants Settling tanks, holding tanks, equipment and wells below floor level.</p>	<p>Oxygen deficiency, chlorine gases, ozone; also possibly methane and hydrogen sulphide produced by decaying debris removed from lake and river water.</p>
<p>Heavy industrial projects Sumps, pits, roasters, digesters, mixers, bins, flues, ducts, conveyors, elevators, bag houses.</p>	<p>The hazards will depend on processes and materials involved but may include methane, hydrogen sulphide, oxygen deficiency, flammable agents, electrical hazards, moving parts, and engulfment due to free-flowing materials.</p>
<p>General construction Vaults, caissons.</p>	<p>Toxic materials such as carbon monoxide from temporary heaters in low-lying areas; refrigerants; high-voltage transmission equipment; physical hazards involving poor lighting and cramped working conditions.</p>

or gravity action. Check with plant personnel on lockout and tagging procedures, and review drawings, plans, and specifications.

➤ **Electrical hazards**

Any exposed conductors or energized equipment should be identified before entry. The presence of water in confined spaces may pose an additional electrocution hazard where electrical circuits, equipment, and tools are used.

➤ **Engulfment due to uncontrolled movement of liquids and solids**

Liquids, sludge, fine solids, and other material may not be completely removed from confined spaces and may present an engulfment or drowning hazard. Use inspection ports and dipsticks, and check with plant personnel to evaluate such hazards.

➤ **Slick or wet surfaces**

You can be severely injured from a slip or fall on icy, oily, wet, or moist surfaces.

➤ **Lighting**

Confined spaces generally have poor lighting. You often need temporary lighting. In potentially explosive atmospheres, use lighting designed for such situations.

ATMOSPHERIC HAZARDS

Confined spaces can present three kinds of atmospheric hazards:

- flammable, combustible, or explosive atmosphere
- oxygen-enriched or oxygen-deficient atmosphere
- atmospheric contaminants.

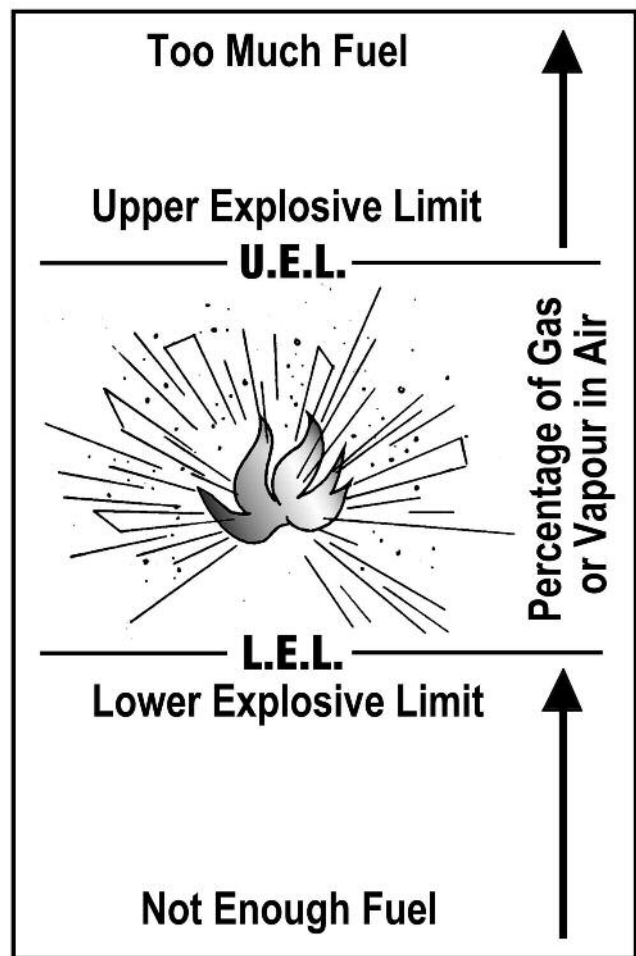
The hazardous atmosphere may be due to existing conditions (e.g., residue in a tank,) or it may be created by the work being done inside the confined space (e.g., welding or using solvents). In some cases, removing sludge or scale can release trapped pockets of gas or vapour and create a hazardous atmosphere. Moreover, dangerous atmospheres often exist together. For instance, flammable, combustible or explosive atmospheres may also be toxic or cause an oxygen deficiency.

FLAMMABLE, COMBUSTIBLE, OR EXPLOSIVE ATMOSPHERES

Flammable atmospheres are generally caused by

- evaporation of flammable liquids (e.g., gasoline)
- by-products of chemical reactions (e.g., decomposition of organic matter to form methane).

Explosive atmospheres are those in which a flammable gas or vapour is present in quantities between the Lower Explosive Limit (LEL) and the Upper Explosive Limit (UEL). These limits define the “Explosive Range” which varies from one substance to another. Refer to the section



“Fire and Explosion Hazard” of a material's MSDS for fire- and explosion-related information.

The LEL is the lowest, and the UEL the highest concentration of gas or vapour that will support combustion. For example, gasoline has an LEL of 1.4% and a UEL of 7.6%. Below 1.4% there is not enough fuel to burn, while above 7.6% there is too much fuel and not enough oxygen to burn. (See figure above.)

The most common explosive gas likely to be encountered in sewers and other underground structures is methane-or “natural gas”-produced by decaying garbage and sewage.

Other explosive gases and vapours may be present in confined spaces depending on previous contents or accidental spills and leaks (e.g., leaking fuel-storage tanks near service stations).

Explosive ranges for common gases and vapours are listed in Table 1. These values must be considered when selecting and operating gas-testing equipment.

Combustible atmospheres can arise in grain elevators, feed mills, and some industrial settings such as bag houses, because of the large quantities of dust generated. The most common combustible dust is grain or flour dust-there have been several explosions in grain elevators. You need to address this issue whenever you're working in these settings.

Table 1
Explosive Range for common gases and vapours

Gas/vapour	Lower Explosive Limit (%)	Upper Explosive Limit (%)
Acetone	2.6	12.8
Ammonia	16.0	25.0
Benzene	1.3	7.1
Ethyl Alcohol	3.3	19.0
Gasoline	1.4	7.6
Hexane	1.1	7.5
Hydrogen Sulphide	4.0	44.0
Methane	5.0	15.0
Methyl Alcohol	7.3	36.0
Propane	2.4	9.5
Toluene	1.2	7.1
Xylene	1.1	7.0

OXYGEN-ENRICHED AND OXYGEN-DEFICIENT ATMOSPHERES

Normal outside air contains about 21% oxygen. If the concentration of oxygen exceeds 23% it is considered “enriched”. The primary concern with oxygen-enriched atmospheres is the increased flammability of materials. Things that would only smoulder in normal air will burn vigorously in oxygen-enriched atmospheres.

Oxygen-enriched atmospheres are fairly rare in construction. They are usually associated with pure oxygen escaping from leaking or ruptured oxyacetylene hoses or, on projects in industrial plants, from an oxygen line in an industrial or manufacturing process.

Oxygen-deficient atmospheres, on the other hand, are fairly common. They may result from work being done (such as welding), bacterial action (which consumes oxygen), or from chemical reactions (such as rusting). Oxygen may also be displaced by another gas or vapour (e.g., carbon dioxide or nitrogen used to purge tanks, pipe, and vessels). Table 2 lists the effects of oxygen deficiency.

Table 2
Effects of oxygen deficiency

Oxygen concentration	Effect
19.5%	Minimum for safe entry
Less than 18%	Loss of judgment and coordination
Less than 15%	Loss of consciousness
Less than 12%	Sudden collapse and loss of consciousness

Never use pure oxygen to ventilate a confined space. Use clean air.

ATMOSPHERIC CONTAMINANTS

Because confined spaces are poorly ventilated, atmospheric contaminants can build up to hazardous levels very quickly. For construction in an industrial setting, the type of airborne hazard that may be encountered depends on

- products stored in the confined space
- the type of work tasks performed in the confined space
- work or processes being performed near the confined space.

The most common atmospheric contaminants in construction include hydrogen sulphide, carbon monoxide, sulphur dioxide, chlorine, and ammonia.

Hydrogen Sulphide (H₂S) is a gas generated by the decomposition of garbage and sewage. H₂S can be found in sewers, sewage treatment plants, refineries, and pulp mills. It is also found in many oil refineries since most crude oil in Canada has some H₂S dissolved in it. H₂S is very toxic. A single breath at a concentration of about 500-700 ppm (parts per million) can be instantly fatal. At very low concentrations, H₂S has the characteristic odour of rotten eggs. However, at about 100 ppm it can deaden your sense of smell and create the false impression that no hazard exists.

Carbon Monoxide (CO) is a very common toxic gas. It has no odour or taste and is clear and colourless. Carbon monoxide poisoning can be very subtle and may cause drowsiness and collapse followed by death. The major sources of CO in construction include the internal combustion engines powering saws, scissor lifts, power trowellers, generators, and forklift trucks. Even these relatively small engines produce high levels of CO.

Heating in confined areas, particularly with propane, presents special hazards and requires special safeguards. Propane is heavier than air and can collect in low-lying areas such as trenches, basements, and shaft bottoms. Propane can also be absorbed into clothing. Workers must therefore use extreme caution in the event of leakage or flame-out.

Direct-fired heaters release combustion emissions directly into the air where people work. Although carbon monoxide (CO) is the main concern, carbon dioxide (CO₂) and nitrogen oxides may also be a problem.

Adequate ventilation is absolutely essential when you cannot avoid using combustion engines in confined spaces.

Traditionally, explosive blasting has been used for demolition or breaking up rock. Blasting in a confined space can produce high levels of carbon monoxide. You must use mechanical ventilation and perform air tests before workers re-enter the blast area to ensure that the carbon monoxide levels are within acceptable levels.

CO in atmosphere (parts per million)	Signs and symptoms
10	No symptoms
25	TWAEV (Time-Weighted Average Exposure Value): The maximum average amount a worker is allowed to be continuously exposed to for a work day or work week.
70	Blood vessels widen, shortness of breath, tightness across the forehead
100	STEV (Short-Term Exposure Value): The maximum amount a worker is allowed to be exposed to for a 15-minute period.
120	Shortness of breath, headache with throbbing in temples
220	Headache, irritability, tiredness, impaired judgment, impaired vision, dizziness
350–520	Headache, confusion, fainting, collapse
800–1220	Unconsciousness, spasms, respiratory failure, death if exposure continues
More than 2000	Rapidly fatal



Do not restrict ventilation by blocking openings

Sulphur Dioxide (SO₂) is a very irritating and corrosive gas with a strong sulphur-like odour which can be found in pulp-and-paper mills and oil refineries.

Chlorine (Cl₂) is another irritating and highly corrosive gas with a bleach-like odour used as a disinfectant in water and sewage treatment plants and a wide variety of other industrial settings.

Ammonia (NH₃) is a fairly common chemical used as a refrigerant and in making fertilizer, synthetic fibres, plastics, and dyes.

Hundreds of other toxic materials may be encountered in factories, chemical plants, and similar industrial settings. The best way to obtain information regarding the presence or absence of toxic materials is to discuss the proposed work with the client and ask for the information.

FLAMMABLE PRODUCTS

When using flammable materials in a confined space, take these precautions:

- ✓ Provide adequate ventilation.
- ✓ Control sparks (use non-sparking tools) and control other potential ignition sources
- ✓ Extinguish all pilot lights.
- ✓ Use specially protected lighting.
- ✓ Have fire extinguishers handy.

Contact cement is an example of a product with fire or explosion potential when used in a small area with poor ventilation. Workers have been killed from explosion and fire when they finished work and switched off the light in a room where solvent vapours from contact cement or adhesives had accumulated.

ACCUMULATION OF CONTAMINANTS BELOW GRADE

Trenches, manholes, and low-lying areas may become hazardous from leaking gases heavier than air-such as propane-or from gasses such as carbon monoxide seeping through the soil and into the confined space.

Case study

A construction crew finished installing a 12-foot-deep manhole without incident. After the crew left the area, 265 pounds of nitroglycerin-based explosive in 20 boreholes, each 18 feet deep, were detonated 40-60 feet from the manhole. A worker who entered the manhole 45 minutes after the explosion collapsed within minutes, and two coworkers descended into the manhole to rescue him. One rescuer retrieved the unconscious worker before collapsing on the surface, and the other rescuer died in the manhole.

An investigation determined that carbon monoxide released from the explosion had migrated through the soil into the manhole. Carbon monoxide concentrations at the bottom of the manhole two days after the incident were 1,905 ppm (parts per million). This concentration was well above 1,200 ppm, the concentration classified as Immediately Dangerous to Life or Health (IDLH). Tests following ventilation of the manhole showed that high levels of carbon monoxide reappeared as a result of continued migration from the surrounding soil. Subsequent monitoring of the manhole showed a decline in carbon monoxide levels over the next 8 days.



Workers should be aware of this hazard. At the first sign of discomfort or disorientation they should leave the area until it has been ventilated.

Workers feeling light-headed or experiencing headaches may be inhaling these pollutants. Drowsiness or disorientation can lead to falls. Again, leave the area until it has been ventilated.

Underground mines, tunnels, and shafts

These spaces are intended for people to carry out work in them-this work is covered by specific regulation. They may present physical or atmospheric hazards. Many utilities are routed through tunnels or underground shafts where hazardous atmospheres may collect from containers or operations above, or be created by utility leaks (such as gas and oil).

Work in shafts must be carefully planned. Because the work may be of short duration and require only a temporary platform, these jobs are often not given proper attention.

In addition to the areas already described, beware of apparently harmless areas such as basements, halls, and small rooms that can become dangerous when a lack of ventilation and hazardous materials or operations combine to create atmospheric hazards.



ACCUMULATION OF CONTAMINANTS IN AREAS NOT CLASSIFIED AS CONFINED SPACES

A variety of spaces can become hazardous because of the products being used or the work being done in them. These areas can be deadly even if they are not classified as confined spaces and even if the confined space provisions of the Construction Regulation do not apply.

Skylights, domes, and ceilings

Work is sometimes required within newly installed skylights where lighter-than-air gases and fumes may accumulate.



If a worker can be injured by inhaling a hazardous gas, vapour, dust, or fume or there is an explosion hazard then you must provide adequate ventilation by natural or mechanical means. If this is not possible then you must provide respiratory protection equipment suitable for the hazard.

PLAN FOR CONTROLLING HAZARDS

Once the hazards have been identified in the assessment, a **competent person** must develop a **plan** to eliminate or control the hazards.

COMPETENT PERSON

means a person who

- a) is qualified because of knowledge, training and experience to **organize the work** and its performance
- b) is familiar with the *Occupational Health and Safety Act* and the regulations that apply to the work, and
- c) has knowledge of any potential or actual danger to health and safety in the workplace.

The primary objective of the **plan** is to eliminate the hazard before entry. If this is not possible, then controls, measures, and procedures must be put in place to ensure that workers are not in danger.

If confined spaces are of similar construction and present the same hazards, a single plan can be used. Still, the individual confined spaces must be identified in both the hazard assessment and the plan.

The Plan is the program element with the most regulatory requirements attached to it. The regulation outlines 11 mandatory requirements that must be contained in the plan:

- 1) Duties of workers
- 2) Coordination document (prepared by the constructor) if workers of more than one contractor enter the same confined space
- 3) On-site rescue procedures
- 4) Rescue equipment (inspected by a competent worker) and methods of communication
- 5) Protective clothing and protective equipment
- 6) Isolation of energy and control of material movement
- 7) Attendants
- 8) Adequate means of access and egress (entry and exit)
- 9) Atmospheric testing (conducted by a competent worker)
- 10) Adequate procedures for working in the presence of explosive or flammable substances
- 11) Ventilation and purging.

We address each of these 11 mandatory requirements below.

1) DUTIES OF WORKERS

- a) Do not enter or re-enter (if the confined space has been left unoccupied and unattended) the confined space unless testing has been performed.
- b) Know the hazards that may be faced upon entry. Know the route of exposure (e.g., inhalation or skin absorption), signs and symptoms, and long-term effects of exposure.
- c) Know how to use the equipment (including personal protective equipment and tools) properly.
- d) Maintain communication with the attendant so that the attendant can monitor your safety and be able to alert workers to evacuate the confined space.
- e) Alert the attendant whenever:
 - you recognize any warning sign or symptom of exposure
 - you see a dangerous condition
 - an alarm is activated.
- f) Get out of the permit space immediately whenever
 - a warning system indicating a ventilation failure is activated
 - the attendant gives an evacuation order
 - a worker recognizes any signs or symptoms of exposure
 - a person inside detects a dangerous condition
 - an evacuation alarm is activated.

2) COORDINATION

When workers of more than one employer perform work in the same confined space, the constructor must coordinate entry operations. The constructor must prepare a coordination document to ensure that the various employers perform their duties in a way that protects the health and safety of all workers entering the confined space.

A copy of the coordination document must be provided to each employer of workers who perform work in the confined space and the project's joint health and safety committee or health and safety representative.

Each employer is responsible for the health and safety of their own workers and for ensuring compliance with the regulation.

3) RESCUE PROCEDURES

The confined space plan must include written procedures for safe onsite rescue that can be implemented immediately in case of an emergency. An adequate number of people must be available to carry out the rescue procedures immediately. They must be **trained** in

- a) the onsite rescue procedures
- b) first aid and cardio-pulmonary resuscitation (CPR)
- c) how to use the rescue equipment necessary to carry out the rescue.

Dialing 911 is not a sufficient rescue response.

4) RESCUE EQUIPMENT

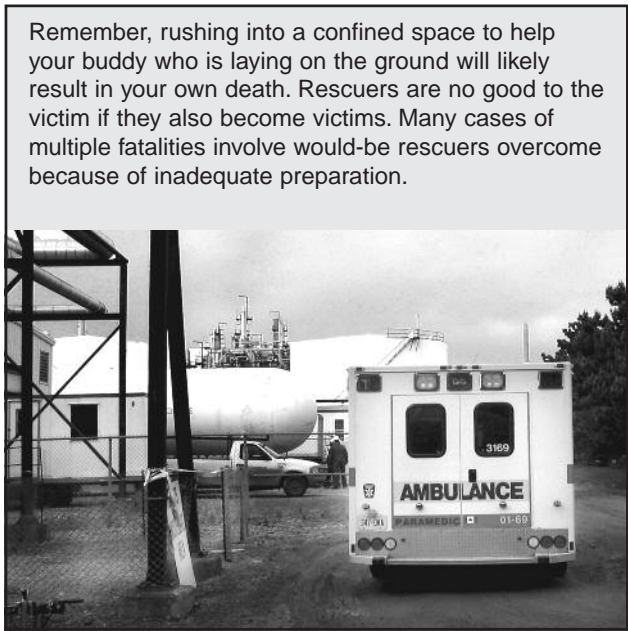
The rescue equipment must be readily available, appropriate for the confined space, and inspected by a competent worker. The competent worker must keep a written record of the inspection. Examples of rescue equipment include harnesses and lifelines, hoist/retrieval systems, respirators, and other personal protective equipment.

NOTE: You must consider the size of the confined space's opening when choosing rescue equipment. There is no point planning for a rescuer to wear a SCBA (self-contained breathing apparatus) unit if it doesn't fit through the opening.

All too often, inadequate or incorrect emergency rescue response results in multiple fatalities. Here are two examples:

- A worker collapsed shortly after entering a degasser tank. His coworker went in after him and collapsed as well.
- A contractor went to test acid-tainted water and was discovered by a worker floating in a well of the above-ground pump house. The worker went to his rescue after calling 911 but was himself overcome. Two paramedics responding to the call were also struck down. All four victims died.

Even with the best planned and executed entry there is a chance of a sudden change in conditions. The change could be due to factors recognized earlier but for which no "absolute" protection exists, such as the failure of a respirator, the introduction of a new hazard, or collapse from heart attack or illness. In such cases you need a rescue plan that has been practiced and works.



Remember, rushing into a confined space to help your buddy who is laying on the ground will likely result in your own death. Rescuers are no good to the victim if they also become victims. Many cases of multiple fatalities involve would-be rescuers overcome because of inadequate preparation.

5) PROTECTIVE CLOTHING AND PERSONAL PROTECTIVE EQUIPMENT

Protective clothing and equipment suitable for one material may not be suitable for others. For example, polyvinyl chloride (PVC) plastic is resistant to most acids, but it can be softened or penetrated by many common solvents such as benzene, toluene, and xylene.

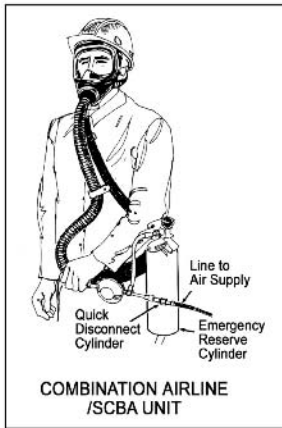
For this reason, a knowledgeable person should assess the protective clothing and equipment needed (e.g., gloves, boots, chemical suits, fire resistant coveralls-as well as hearing, respiratory, eye, and face protection). Don't forget that if workers need personal protective equipment, they must be trained in its use.

Respiratory protective equipment should be used where ventilation is impractical or inadequate. Certain basic rules apply to the equipment.

First of all, you need to select the proper type of respirator. Oxygen-deficient atmospheres require supplied-air respirators—either airline types with emergency reserves or SCBA (self-contained breathing apparatus) as in the figures on the next page.

SCBA note: Because the amount of air supply in standard SCBA cylinders is rated for a specific time period, it is very important to plan your tasks, especially rescues operations, accordingly. Heavy work and stress will increase breathing rates and workers will use up the air in less than the rated time. An alarm sounds when the air supply is low.

In toxic atmospheres, you must use supplied-air respirators if the concentration of the gas or vapour exceeds the level considered to be Immediately Dangerous to Life or Health (IDLH), or if the concentration is unknown.



COMBINATION AIRLINE /SCBA UNIT



SELF-CONTAINED BREATHING APPARATUS (SCBA)

When the level of toxic gas or vapour is above the exposure limit but below the IDLH level, air-purifying respirators approved by the National Institute of Occupational Safety and Health (NIOSH) may be used provided the exposure conditions do not exceed the unit's limitations. Someone who is competent in respirator selection must determine the appropriate type of respirator.

Workers required to wear respirators must be instructed how to properly fit and maintain them. For more information on respiratory protection, refer to the chapter on Respiratory Protection in this manual, or the Canadian Standards Association's standard Z94.4-02, *Selection, Use, and Care of Respirators*.

Do not use single-strap dust masks and surgical masks—they are not approved by the National Institute for Occupational Safety and Health (NIOSH). NIOSH is a U.S.-based organization that approves respirators. Workers must be supplied with NIOSH-approved respirators only. All NIOSH-approved respirators have an approval number (always starting with the letters TC) on them.

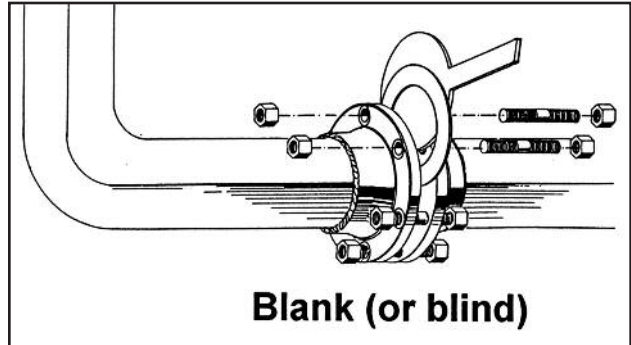
Make sure your respirator has all the proper parts. Since each manufacturer uses different designs, parts are not interchangeable between brands. Make sure you use the correct parts (cartridges, air cylinders, etc.) for your brand of respirator. Never use cartridges or air cylinders from another manufacturer. They will not fit correctly and will endanger the life of the worker or rescuer.

6) ISOLATION OF ENERGY AND CONTROL OF MATERIAL MOVEMENT

Equipment that moves in any way (even rotation) must be isolated by

- ❑ disconnecting the equipment from its power source and de-energizing the equipment, or
- ❑ lockout and tagging. Only workers trained in lockout and tagging should perform such operations. Lockout and tagging should be done even if you use the first option (disconnect and de-energize) to isolate the energy.

For pneumatic or hydraulic equipment, isolate the power source and depressurize the supply lines. Depressurize any components that may still be pressurized after the supply lines have been bled—hydraulic cylinders for example. You must disconnect and drain pipes carrying solids or liquids to or from a confined space, or insert blank flanges.



If the pipe cannot be blanked off or disconnected, the valve may be closed, chained, locked and tagged, provided that

this type of control—and its importance—have been explained to all workers in the area. **Simply closing valves is not generally acceptable.**



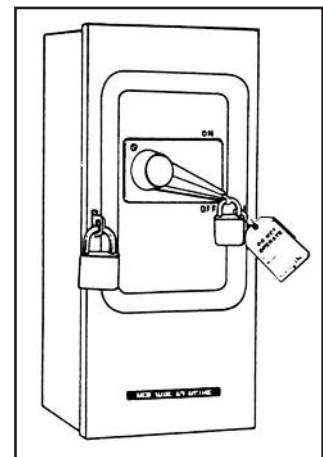
You may need blocking to prevent movement caused by gravity for some equipment (e.g., conveyors).

Electrical equipment in the space should be disconnected, tagged and locked out, and grounded when it's practical to do so.

In the case of live electrical work in a confined space, you need to pay special attention to standard procedures. A minor mistake in a manhole can lead to disaster.

Cramped working conditions can make accidental contact with an energized conductor more likely, so you may need non-conductive equipment.

You may need gloves, mats, and other insulating equipment depending upon the type of work. Capacitors or other components which can store a charge should be discharged and/or grounded.



7) ATTENDANT

An attendant must be present whenever a worker enters a confined space. The attendant is not allowed to enter the confined space, unless he or she is replaced by another attendant in accordance with the plan.

The attendant must

- ✓ remain alert outside and near to the entrance
- ✓ be in constant communication (visual or speech) with all workers in the confined space
- ✓ monitor the safety of workers inside the confined space
- ✓ provide assistance as necessary
- ✓ be provided with a device for summoning help in case of emergency, and
- ✓ initiate an adequate rescue procedure in case of an emergency.

The attendant is not allowed to enter the confined space to perform a rescue even after help has arrived unless he or she is replaced by another attendant in accordance with the plan.

8) ENTRY AND EXIT (ACCESS AND EGRESS)

The means of entry and exit can be evaluated before entry by checking drawings, by prior knowledge, or simply by inspection from outside the space.

Confined space openings are generally small and not well located. These small openings must be considered in the rescue plan since they restrict the movement of workers and equipment in and out of confined spaces.

Entry and exit for top-side openings may require ladders. Ladders must be well secured. Performing an emergency rescue on workers trapped in such areas requires careful planning and practice.



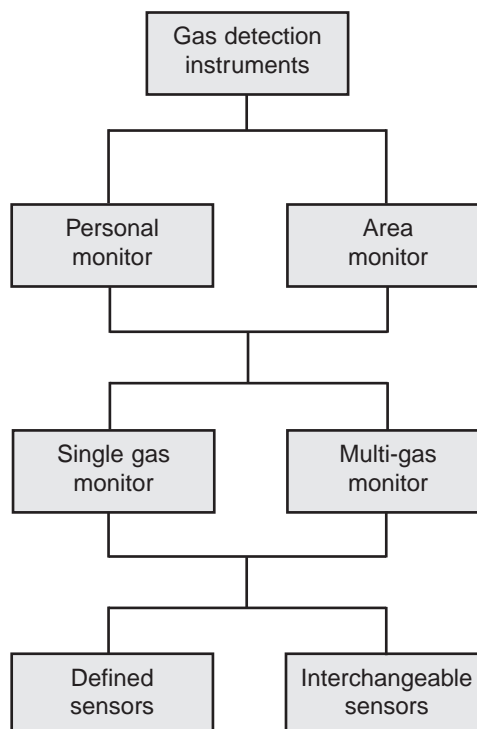
9) ATMOSPHERIC TESTING

If the hazard assessment determines that there is an atmospheric hazard in the confined space, you must perform atmospheric testing.

- 1) The employer must appoint a competent worker to perform adequate tests safely before and during the time a worker is in a confined space to ensure that acceptable atmospheric levels are maintained. The competent worker who will perform the tests must receive training in the operation, calibration, and maintenance of the instruments. Most manufacturers can provide necessary training.
- 2) If the confined space has been left unoccupied and unattended, you must perform the testing again.
- 3) The competent worker performing the tests must use properly calibrated and maintained instruments appropriate for the hazards in the confined space.
- 4) Results of every sample of a test must be recorded on the entry permit. If continuous monitoring is performed, test results must be recorded at adequate intervals.

Gas detection instruments

Gas detection instruments can take many forms- "personal" or "area," single-gas or multiple-gas detectors, detectors with dedicated sensors or those with interchangeable sensors.



If a monitor is worn by the worker it is referred to as "personal monitoring."

Personal monitoring gives information about the concentration of hazardous substances

surrounding the worker. It is particularly useful when the worker is moving from place to place within the confined space.



Area sampling is done before entry or re-entry. As much of the confined space area as possible should be tested, including the bottom, mid level, top, and corners.

Single-gas detectors measure only one gas while multi-gas monitors are available with several toxic sensor options and have the flexibility of measuring many gases simultaneously. Most multi-gas monitors include an oxygen sensor, a flammable/combustible gas sensor, and one or two sensors for detecting specific toxic gases. Newer single and multi-gas instruments offer the flexibility of interchangeable sensors. You can change the sensors to suit the application in hand. For example, a single-gas detector used to check hydrogen sulphide levels can be used to monitor carbon monoxide concentrations after you change the sensor.



Key steps to follow when you suspect a dangerous atmosphere

Select the appropriate type of calibrated instruments for the hazards identified in the assessment.

You must understand the characteristics of the work area in order to choose the right instruments. Different types of confined spaces present different kinds of toxic gas hazards. There are hundreds of different toxic gases or vapours. You need a familiarity with the characteristics of the confined space in order to narrow down the possibilities and choose equipment.

You must use a calibrated monitor that is capable of measuring the hazardous atmosphere found in the confined space. For example, if a propane heater is being used inside a confined space, then you need calibrated monitors capable of measuring oxygen levels, carbon monoxide, and combustible gases.

WARNING: Combustible gas detectors should not be used to assess toxic atmospheres. Most combustible gas detectors do not respond to low concentrations of gases. For example, H₂S is flammable from 4.3% to 44%. But it is Immediately Dangerous to Life or Health (IDLH) at 100 parts per million (0.01%) and would not be detected at this concentration by most combustible gas detectors. Most other toxic gases that are also flammable are

You must calibrate, maintain, and use the equipment in accordance with the manufacturer's recommendations.

If the meter is not properly calibrated, you cannot rely upon its results. Deaths can occur if the instrument underestimates the atmospheric conditions.

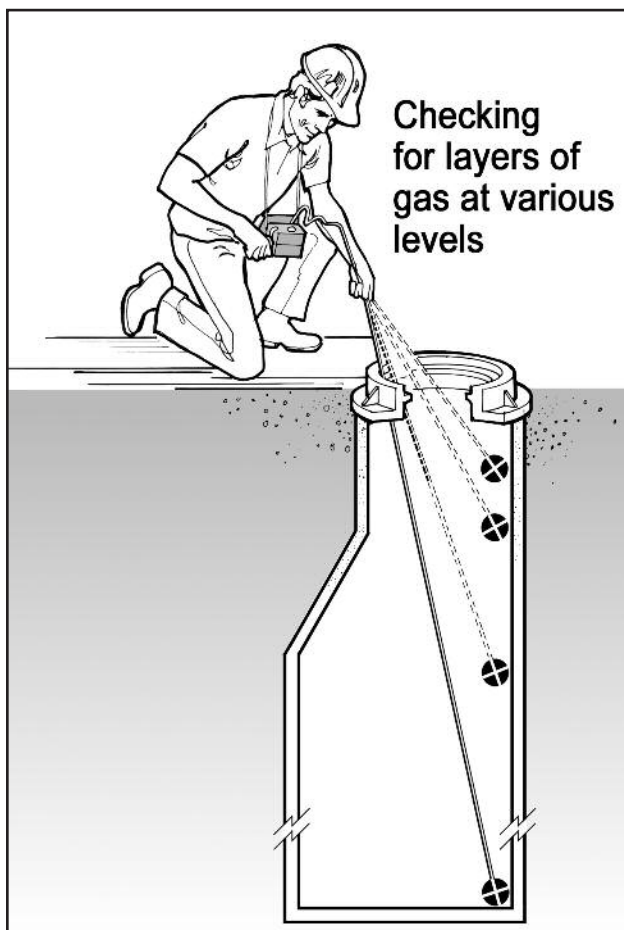
Most confined-space instrument manufacturers now offer "docking" stations that can automatically calibrate instruments and print a record of calibration. The stations also recharge and store the instruments.



Perform the tests safely.

Entry into a confined space must be prohibited before the appropriate tests are performed. Atmospheres should be evaluated remotely (from outside the confined space) before each entry. If possible, an extendable probe should be inserted through an inspection port or other opening before removing large doors or covers.

Make sure that as much of the space as possible is tested, including the bottom, mid-level, top, and corners, so that you don't miss layers or pockets of bad air. (See figure below). There are some gases that are lighter or heavier than air. Lighter gases, such as methane, will accumulate at the top, while gases heavier than air will sink to floor level. Gases that are the same weight as air, such as carbon monoxide, will be found throughout a confined space.



Check for oxygen content, combustible or explosive gases and vapours, and toxic gases and vapours, in that order if you use more than one meter.

First, check for oxygen content. Checking oxygen first is important because you may need adequate oxygen to get a valid result from other tests.

If the oxygen level is adequate, test for explosive atmospheres. Several different calibration gases are available. Methane is used most frequently since it is a common gas found in many places. But you can get devices calibrated for propane, hexane, heptane, or almost any other combustible gas. These devices give a

result expressed as a percentage of the lower explosive limit (LEL) for the calibration gas used.

The next thing to check for is the presence of toxic gases and vapour using a calibrated instrument.

If you're using a multi-gas monitor capable of measuring oxygen, combustibles, and toxic gases simultaneously then the order of testing is not as critical.

All three types of dangerous atmospheres must be evaluated before entry. Users of gas detectors must be competent workers. They must also receive training in the operation, calibration, and maintenance of the devices. Most manufacturers can provide necessary training.

Always test for the three dangerous atmospheres:

- too much or too little oxygen
- combustible or explosive gases or vapours
- toxic gases or vapours.

You may need to monitor the atmosphere continuously.

Continuous monitoring in a confined space is required while hot work is being performed in a potentially flammable or explosive atmosphere or where the flammable or explosive atmosphere has been rendered inert by adding an inert gas. It should also be considered when conditions in the confined space change rapidly.

If continuous monitoring is performed then test results must be recorded at regular intervals.

Most confined space instruments have data-logging capabilities. Data-logging is useful for compliance and record-keeping purposes. If an accident or unusual event happens, data-logging may be useful for demonstrating due diligence.

Interpret the results.

There may be other gases present in the confined space that interfere with the reading for the gas you are trying to measure. Such gases are referred to as "interfering gases." They can lead to misinterpretation of the

Know the limitations of your specific equipment. Consult the manufacturer's instructions for proper use.

Temperature, humidity, and interfering gases can all affect the performance of gas monitors.

monitoring results.

If the atmosphere meets acceptable exposure limits (see next page) the confined space may be entered. If the atmosphere does not meet acceptable limits, you need to implement controls before anyone can enter.

Acceptable atmospheric levels	
Explosive or flammable gas or vapour	<p>< 25% of its lower explosive limit: inspection work can be performed.</p> <p>< 10% of its lower explosive limit: cold work can be performed. (Cold work is work which does not involve</p> <ul style="list-style-type: none"> – welding and cutting – the use of tools or equipment which can produce a spark – other sources of ignition.) <p>< 5% of its lower explosive limit: hot work can be performed.</p>
Oxygen content	At least 19.5% but not more than 23% by volume.
Exposure to atmospheric contaminants	<p>Exposures to atmospheric contaminants must not exceed what is reasonable in the circumstances (section 221.2 (c) of the Construction Regulation).</p> <p>The exposure limits in the regulation on Control of Exposure to Biological or Chemical Agents (Ontario Regulation 833) and the Designated Substance Regulations* are generally considered reasonable for protecting workers.</p>
<p><i>* This is the case despite the fact that construction projects are, strictly speaking, exempt from Regulation 833 and most of the Designated Substance Regulations. (The Designated Substance Regulation which does apply to construction is O. Reg. 278/05: Designated Substance—Asbestos on Construction Projects and in Buildings and Repair Operations.)</i></p>	

If measurements are within acceptable exposure limits but are approaching hazardous levels, the competent worker's decision to proceed should be based on an assessment of the source of the problem, the likelihood of change, and the conditions at the scene. In doubtful cases, it is best to implement the appropriate controls discussed in the following section.

Recording the results.

The test results must be recorded on the work entry permit. The records must be kept by the constructor or employer for at least one year after the project is finished.

- ★ Never trust your senses to determine whether the atmosphere in a confined space is safe.
- ★ You cannot see or smell many toxic gases and vapours.
- ★ You cannot determine by your senses the level of oxygen present.
- ★ Know which gases or vapours may be present in the confined space and test for them.

10) COMBUSTIBLE, EXPLOSIVE, OR FLAMMABLE ATMOSPHERES

No worker is allowed to enter a confined space if airborne **combustible** dust or mist is present in a concentration sufficient for explosion. If an **explosive** or **flammable** atmosphere is detected, you can perform only certain types of work. The conditions for each type of work are specified below the following definitions.

Hot work means activities that could produce a source of ignition such as a spark or open flame. Examples of hot work include welding, cutting, grinding, and using non-explosion-proof electrical equipment.

Cold work means activities that cannot produce a source of ignition.

- a) Between 0% and 5% of the LEL, you can perform hot work. The following conditions must also be met:
 - The oxygen content must be maintained below 23%
 - The atmosphere must be continuously monitored.
 - The entry permit must include adequate provisions for hot work, and it must specify the appropriate measures to be taken.
 - An alarm and exit procedure must be in place to provide adequate warning and allow safe escape if the atmospheric concentration exceeds 5% of the LEL or if the oxygen content exceeds 23%.
- b) Between 0% and 10% of the LEL, you can perform cold work.
- c) Between 0% and 25% of the LEL, you can perform inspection work.

Alternatively, work may be carried out in the confined space if the combustible, explosive or flammable atmosphere is rendered inert by an inert gas (such as nitrogen, argon, helium, or carbon dioxide).

Inerting is the process of replacing the potentially combustible atmosphere in a confined space with a noncombustible gas such as nitrogen, argon, helium, or carbon dioxide.

The atmosphere must be monitored continuously to ensure it remains inert. The worker in the confined space must use adequate respiratory equipment as well as adequate equipment to help people outside the confined space locate and rescue the worker if a problem occurs.

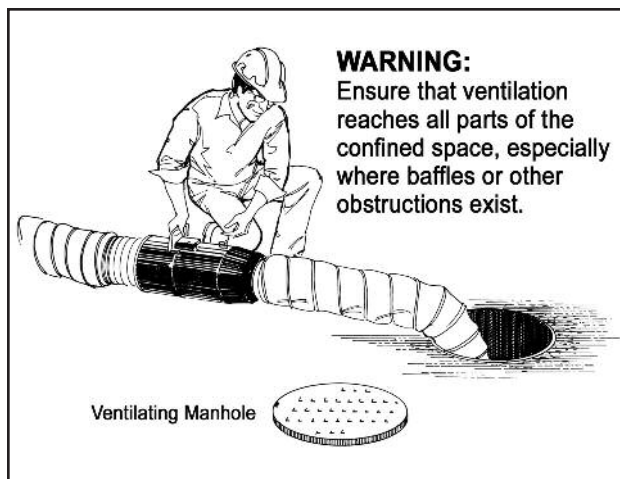
The inert gas will replace all of the **oxygen** as well as the combustible gases in the confined space. Workers entering the confined space should use NIOSH-approved **air-supplied** respirators. After work is completed, the confined space must be properly ventilated, and a competent worker must test the confined space to see if it is safe.

11. VENTILATION/PURGING

This is the most effective method of control. The space can be purged of dangerous atmospheres by blowing enough fresh air in, and/or by removing (or suction-venting) the bad air and allowing clean air in. Studies have shown that the best results are obtained by blowing fresh air into a space close to the bottom. Check the efficiency of ventilation by re-testing the atmosphere with the gas detection equipment before entry.

When ventilation is used to improve the air in a confined space, ensure that the toxic or flammable gases or vapours removed from the space do not pose a risk to other workers. "Exhaust air" should not be discharged into another work area.

If you use mechanical ventilation to maintain acceptable atmospheric levels by providing a continuous supply of fresh air, you must have a warning system (i.e., an alarm) and exit procedure in case there is a ventilation failure. The alarm should be activated by a pressure switch *at the fan* rather than by electrical failure. This ensures that the alarm is activated if the fan belt fails.



A typical manhole 10 feet deep and 5 feet wide contains 196 cubic feet. Blowing in 750 cubic feet per minute should provide an air change every 15 seconds and easily dilute or displace most dangerous atmospheres.

Fans capable of moving 5,000 cubic feet per minute are available for use in larger tanks and vessels.

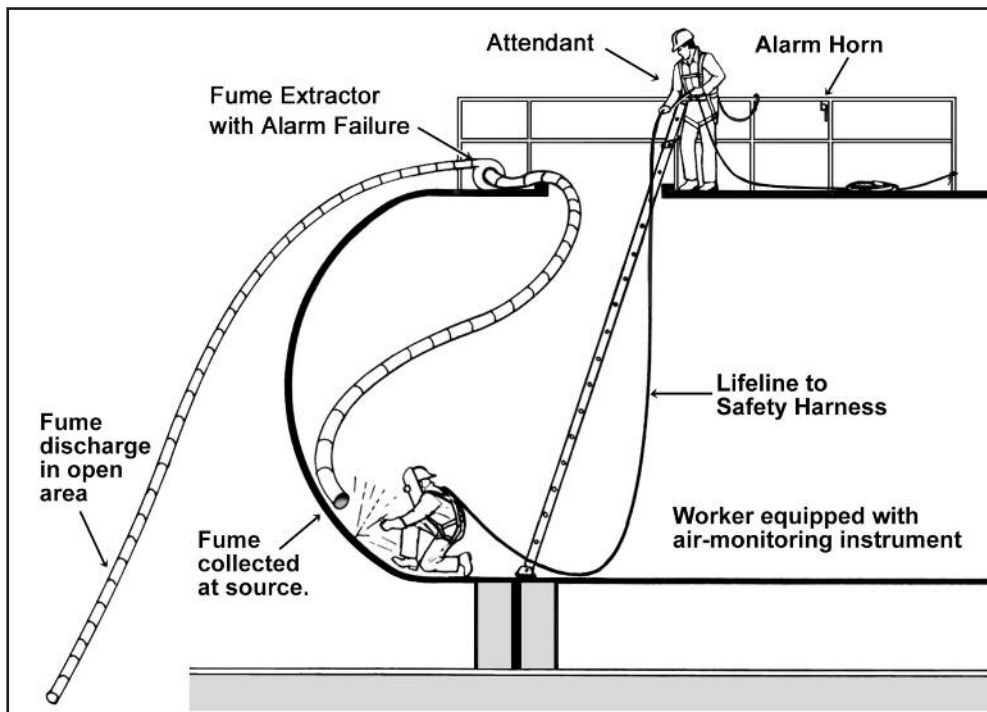
This type of ventilation may not be adequate in situations where additional toxic or explosive gases or vapours may be generated (e.g., during cleaning and resurfacing tanks or by disturbing sludge and scale).

In the case of welding or other work which generates a localized source of toxic gas, fume, or vapour, an exhaust ventilator can be used to draw out and discharge the hazard in an open area. (See figure below.)

Options must be evaluated by someone who understands the risks of the work being done.

In cases where the concentration of explosive gas or vapour is higher than the UEL, ventilation will bring the concentration down into the "Explosive Range." This is one reason why you should use only "explosion-proof" fans. These may be specially designed fans powered by electricity or compressed air. Some pneumatic air movers may also be suitable.

For manholes, you can use portable fans. These usually provide around 750-1,000 cubic feet of air per minute.



WORKER TRAINING

Workers must be trained before they enter a confined space. The training must include

- ✓ recognizing the hazards (including potential hazards) in the confined space
- ✓ safe work practices, including the use of all equipment such as ventilation equipment, air monitors, and personal protective equipment.

It is strongly recommended that

- the employer use an evaluation procedure (a test) to ensure that workers have acquired the knowledge necessary to safely perform their duties
- inexperienced workers team up with experienced workers.

You must review the content of the training at least annually, and whenever there is a change in circumstances such as a change in an industrial process. If the review indicates that the training is not adequate, you must provide additional training.

You must keep a record of the names of trainers, trainees, as well as the date of training. If the project's joint health and safety committee or health and safety representative wants a copy of the record, you must provide one.

ENTRY PERMITS

Permits are valuable tools for planning, evaluating, and controlling confined space entries.



A permit involves a formal system of procedures and is issued by the employer before any worker enters the confined space. A competent person must verify that the permit issued complies with the plan before every shift. The duration of an entry permit must not exceed the time required to complete the task. Entry permits should be understood by everyone involved in the job and must be readily available to every person entering the confined space.

At the very least, the entry permit must include

- the location and description of the confined space
- a description of the work
- a description of the hazards and the corresponding controls
- the time period for which the entry permit applies
- the name of the attendant
- a record of each worker who enters and leaves
- a list of the equipment required for entry and rescue, and verification that the equipment is in good working order
- the results of the atmospheric testing
- additional procedures and control measures if hot work is to be done.

The entry permit may also include

- a record of the hazard assessment
- the hazard control plan
- the training records.

See four pages ahead for a sample of an entry permit form.

Unauthorized entry

The constructor must ensure that each entrance to the confined space is secured against unauthorized entry and/or has adequate barricades or signs warning against unauthorized entry.



RECORD KEEPING

The employers must keep records of every

- ✓ plan
- ✓ assessment
- ✓ coordination document
- ✓ training
- ✓ entry permit
- ✓ record of rescue equipment inspection
- ✓ record of tests.

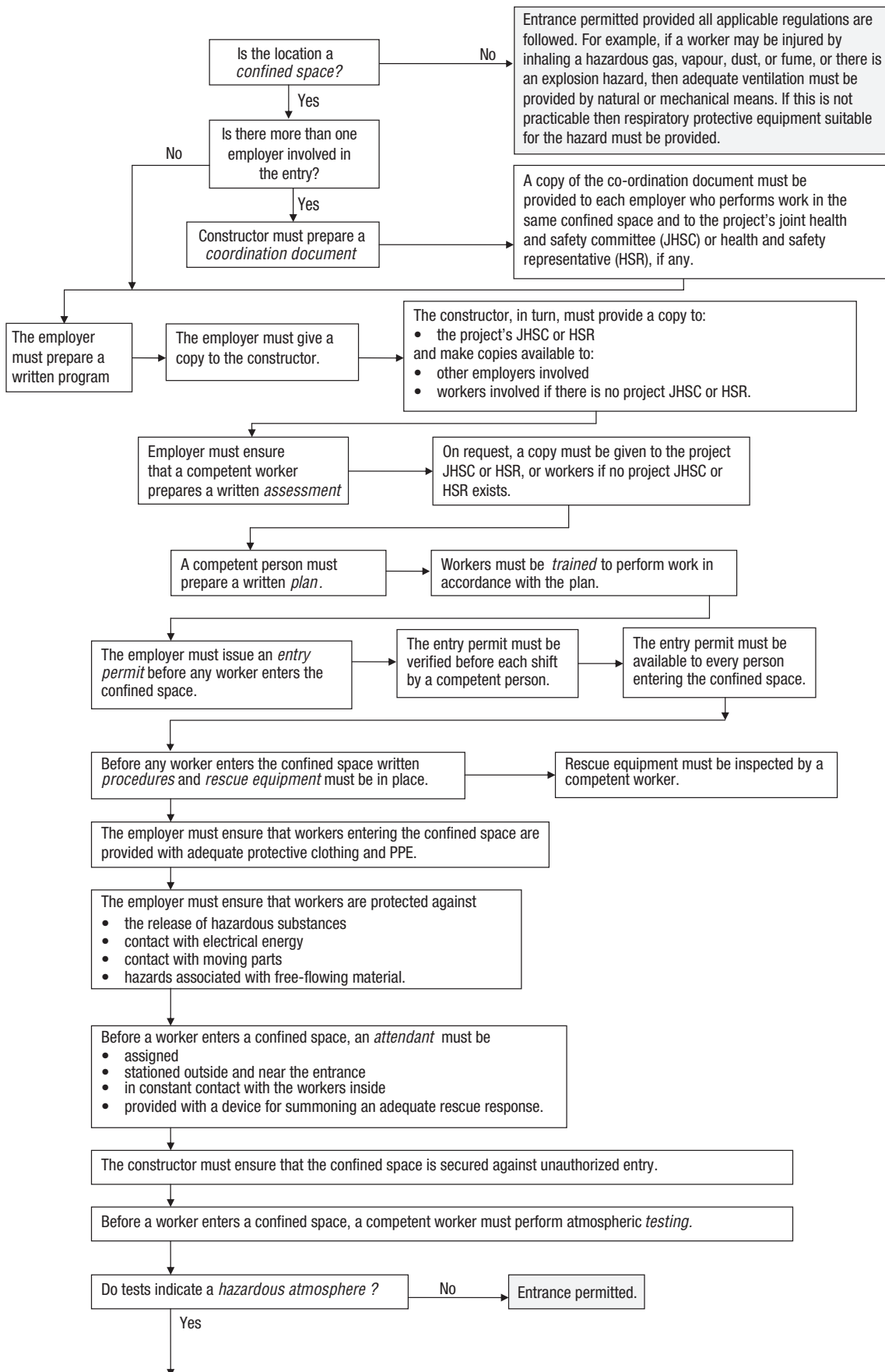
The records must be kept for at least one year after the project is finished, and they must be available for inspection.



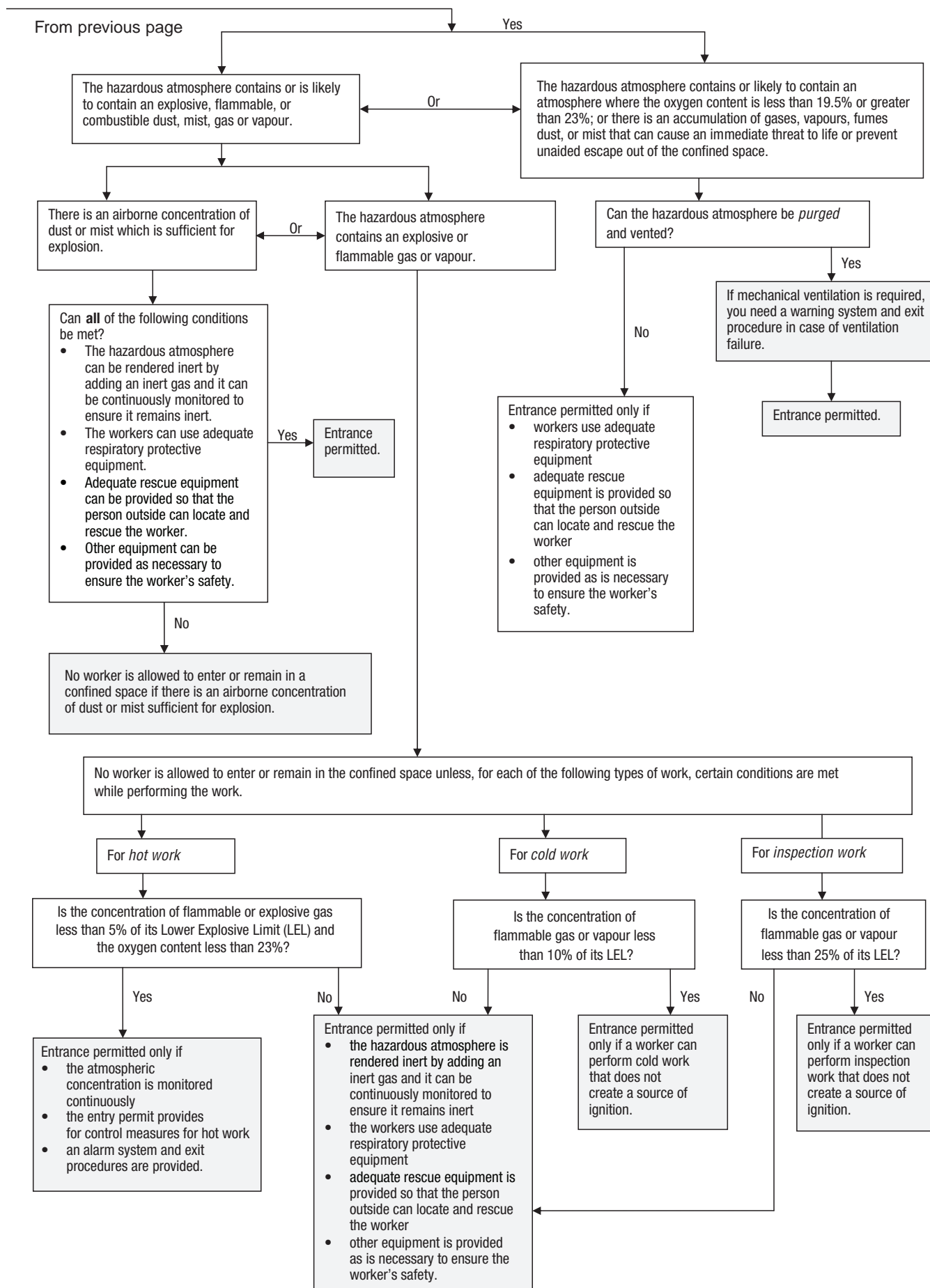
See next few pages for

- **a decision tree for confined space entry**
- **a sample confined space entry permit.**

DECISION TREE FOR CONFINED SPACES



To next page



Sample confined space entry permit

Employer name _____ Project name _____

Date _____ Permit end time _____

Assessment performed by _____ Permit start time _____

Location of confined space (or spaces if they are similar)
Description of confined space (or spaces if they are similar)
Description of work to be performed

Monitoring equipment

Air testing equipment	Serial #	Last calibrated

Air quality results

	Location:			Location:			Location:		
	Test #			Test #			Test #		
	1	2	3	1	2	3	1	2	3
Time of test									
Oxygen, %									
Combustibles, %									
Atmospheric hazard:									
Atmospheric hazard:									
Atmospheric hazard:									
Other:									

Tester's name _____ Signature _____

Controls

Atmospheric hazards (existing or introduced)		Hazard controls		Personal protective equipment (type)
Flammable	<input type="checkbox"/>	Purge using mechanical ventilation equipped with warning device in case of failure.	<input type="checkbox"/>	Respirator _____
Toxic	<input type="checkbox"/>			Gloves _____
Corrosive	<input type="checkbox"/>	Natural ventilation (re-test / air quality)	<input type="checkbox"/>	Boots _____
Oxygen deficient	<input type="checkbox"/>			Coveralls _____
Oxygen enriched	<input type="checkbox"/>			Eye protection _____
Other: _____	<input type="checkbox"/>	Continuous monitoring	<input type="checkbox"/>	Other: _____
		Other: _____	<input type="checkbox"/>	

Physical hazards		Hazard controls		Personal protective equipment (type)	
Hot temperature	<input type="checkbox"/>	Ventilation	<input type="checkbox"/>	Hearing protection	<input type="checkbox"/>
Cold	<input type="checkbox"/>	De-energize, lockout	<input type="checkbox"/>	Anti-vibration gloves	<input type="checkbox"/>
Noise	<input type="checkbox"/>	Blank, disconnect	<input type="checkbox"/>	Other gloves: _____	<input type="checkbox"/>
Electricity	<input type="checkbox"/>	GFCI cords	<input type="checkbox"/>	Goggles	<input type="checkbox"/>
Vibration	<input type="checkbox"/>	Lighting	<input type="checkbox"/>	Fall protection	<input type="checkbox"/>
Slippery surface	<input type="checkbox"/>	Other: _____	<input type="checkbox"/>	Other: _____	<input type="checkbox"/>
Lighting	<input type="checkbox"/>				
Work at height	<input type="checkbox"/>				
Moving machinery	<input type="checkbox"/>				
Influx of liquid	<input type="checkbox"/>				
Influx of gas	<input type="checkbox"/>				
Hazard above	<input type="checkbox"/>				
Other: _____	<input type="checkbox"/>				

Attendant

Attendant's name _____	Signature _____
------------------------	-----------------

Communications

Method of communication with workers _____	Method of communication to summon rescue _____
---	---

On-site rescue

Adequate number of trained persons are available to implement rescue procedures	<input type="checkbox"/>
---	--------------------------

Appropriate rescue equipment is readily available to be used for a rescue	<input type="checkbox"/>	Appropriate rescue equipment has been inspected and is in good working order:	<input type="checkbox"/>
List of equipment required for entry		<input type="checkbox"/> Respirator	<input type="checkbox"/> Coveralls
Tripod <input type="checkbox"/> Harness <input type="checkbox"/> Winch/cable <input type="checkbox"/> Other: _____			

Training

Names of workers approved for entry	Has confined space training	Trained in the entry plan	Time of entry	Time of exit

Hot work (complete if hot work will be conducted)

Will space be rendered inert by adding inert gas? Yes No

If "yes," ensure

- space is monitored continuously to ensure it remains inert
- worker(s) entering use adequate respiratory equipment – list equipment: _____
- there is adequate equipment to allow persons outside to locate and rescue worker – list equipment: _____
- there is other equipment necessary to ensure safety of worker – list equipment: _____

If "no," ensure

Flammable gas is maintained below 5% of its LEL by purging and continuous ventilation	O ₂ content is maintained below 23%	Atmosphere will be monitored continuously	Alarm and exit procedures are in place should the LEL exceed 5% or the O ₂ exceed 23%
<input type="checkbox"/>	<input type="checkbox"/>	<input type="checkbox"/>	<input type="checkbox"/>

Supervisor's name _____ Signature _____

34 ASBESTOS

This chapter provides some brief information about asbestos in construction. If you encounter asbestos on the job, you will need more information. Here are the two main sources of further information on asbestos in Ontario construction:

The legal requirements for handling, working with, removing, and disposing of asbestos and asbestos-containing products are described in **Designated Substance—Asbestos on Construction Projects and in Buildings and Repair Operations (Ontario Regulation 278/05)**. Read the regulation to get a full description of your legal duties. You can get a copy from the Construction Safety Association of Ontario (CSAO), or read it on www.csa.o.org.

In addition, CSAO publishes **Asbestos: Controls for Construction, Renovation, and Demolition (DS037)**. It contains more information than what's in this chapter, and it tells you how to protect yourself. It can also help you understand the asbestos regulation. You can order a copy from CSAO or download it from www.csa.o.org.

WHAT IS ASBESTOS?

Asbestos is a naturally occurring material once used widely in the construction industry. Its strength, ability to withstand high temperatures, and resistance to many chemicals made it useful in hundreds of applications.

But asbestos can also kill. When inhaled, asbestos has been shown to cause the following diseases

- asbestosis
- lung cancer
- mesothelioma (cancer of the lining of the chest and/or abdomen).

The early widespread use of asbestos has left a potentially dangerous legacy. The improper handling of asbestos-containing products can release harmful amounts of fibre.

You need to protect yourself, your coworkers, your family, and others from asbestos. Read the following pages and the respirator chart at the end of the chapter.

WHERE IS IT?

Most structures built between 1930 and 1975 will contain products having substantial amounts of asbestos. See the illustrations on the next page and the chart below.

ASBESTOS PRODUCTS IN CONSTRUCTION			
Product	Residential	Commercial/ Institutional	Industrial
Sprayed-On Fireproofing		XX*	
Pipe and Boiler Insulation	X	X	XX
Loose Fill Insulation	X**		X
Asbestos Cement Products	X	X	X
Acoustical Plaster	X	X	
Acoustical Tiles	X	XX	
Vinyl Asbestos	X	X	
Gaskets		X	XX
Roofing Felts	X	X	X
Asphalt/Asbestos Limpet Spray			X
Drywall Joint-Filling Compound	X	X	
Coatings and Mastics	X	X	X

*Denotes extensive use. **Vermiculite insulation.

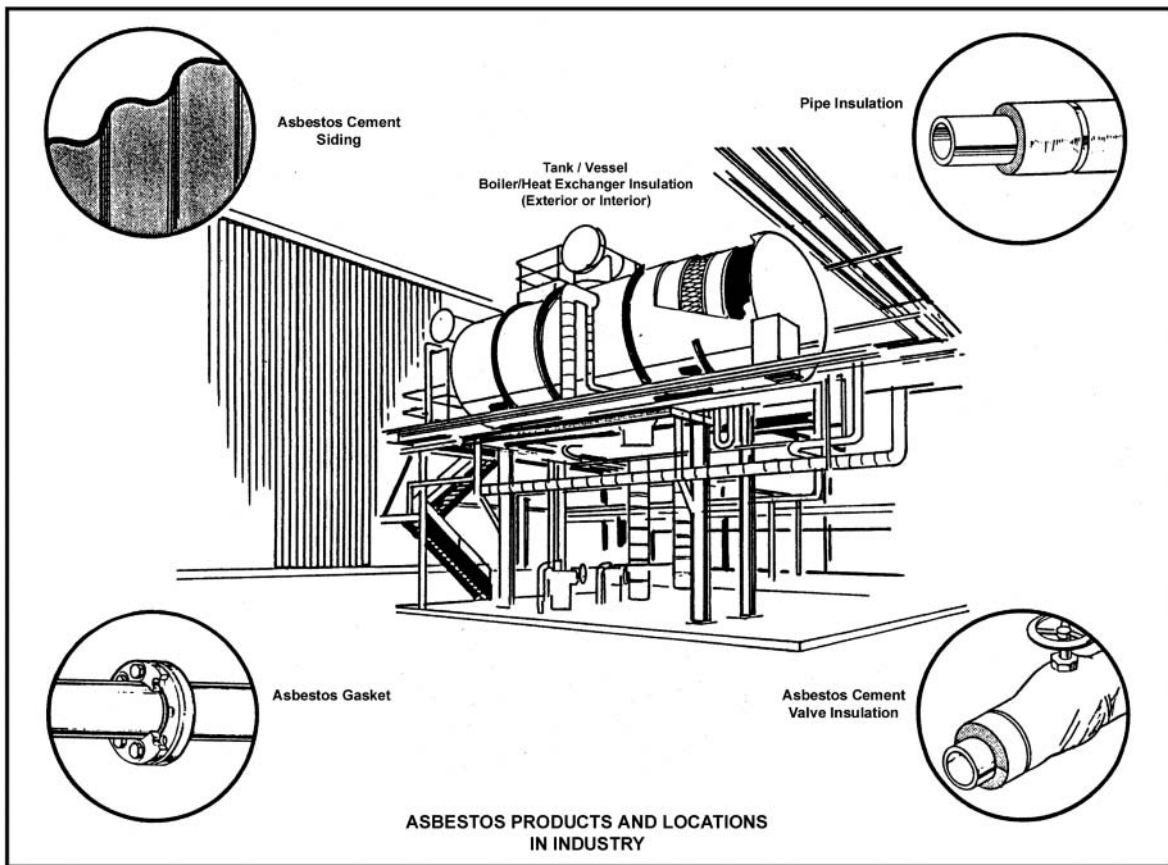
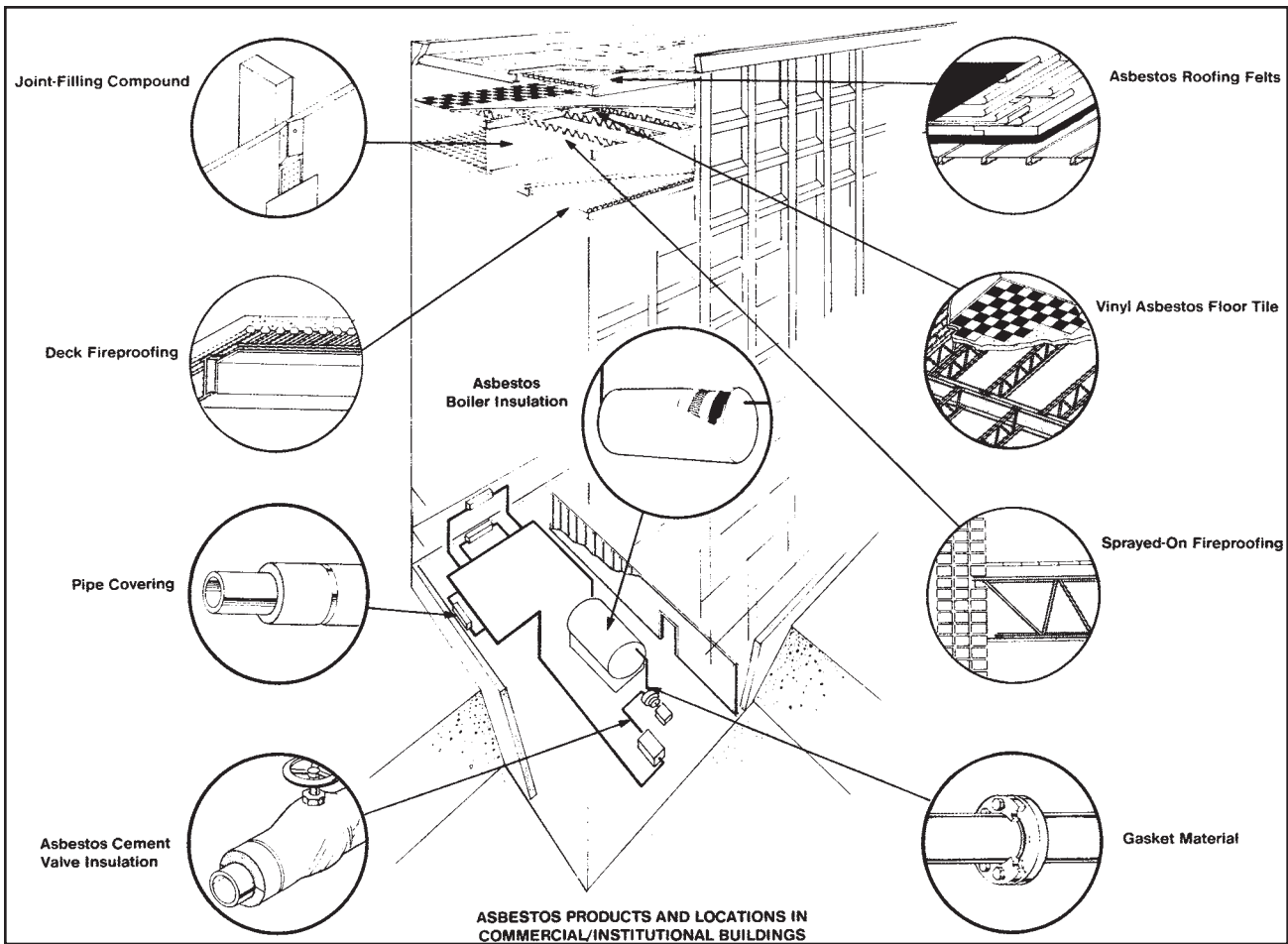
If you have any concerns about material that you believe may be asbestos, have it checked **before** work is started. Otherwise, treat the material as if it is asbestos.

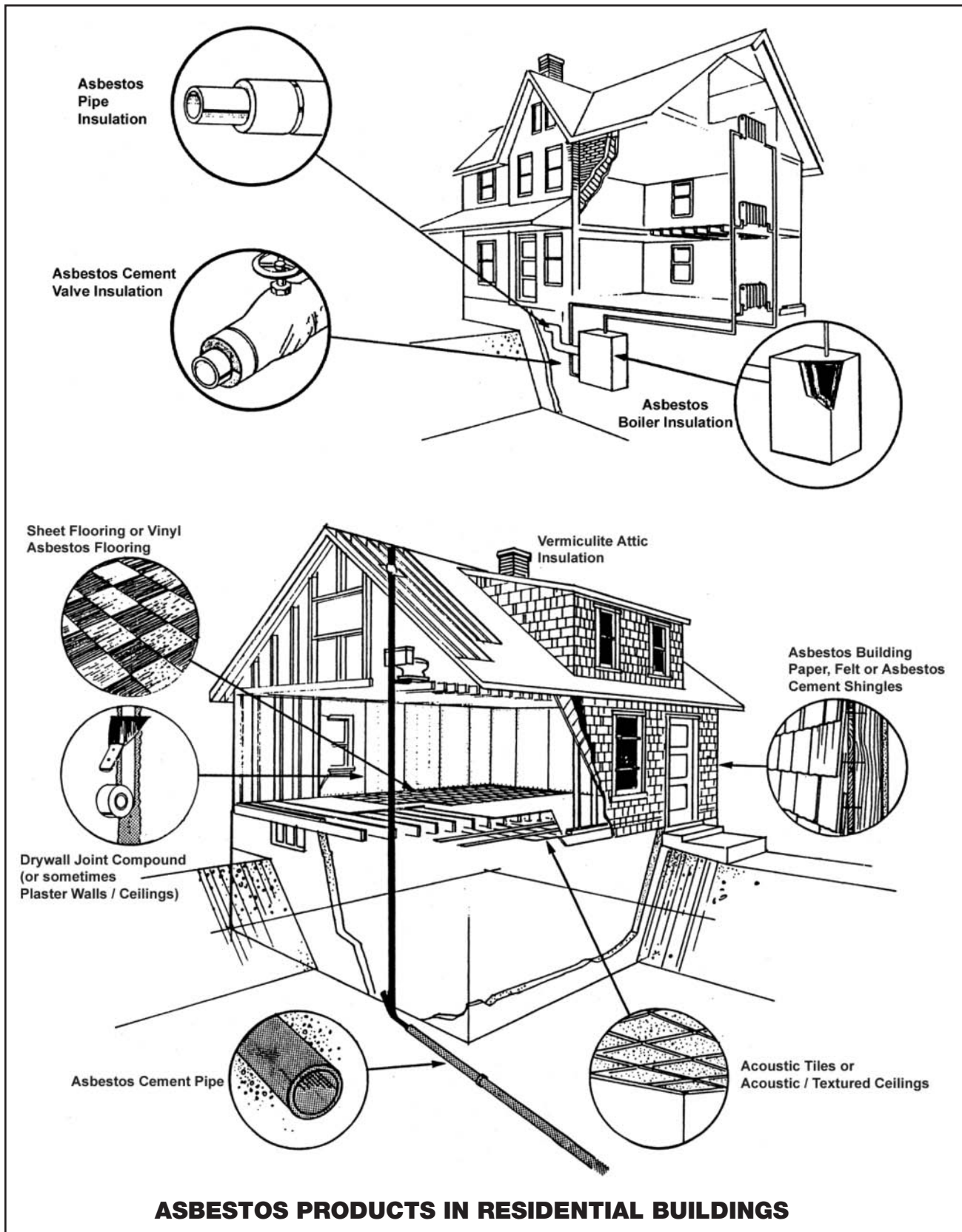
Workers in the carpentry, drywall, resilient flooring, and acoustic and interior systems trades may encounter asbestos in

- light fixtures
- light troughs
- soffits
- transite tile over stairways
- soffits of plazas
- ceiling tile
- 2' x 2' porous tile
- exterior cladding
- insulation
- pre-1980 drywall joint compound
- caulking materials
- gaskets and packings.

Sanding creates fine airborne dust which may stay airborne for 24 hours or longer. Air movements created by heating and air-conditioning systems will spread these airborne fibre particles throughout the building unless the work area and ductwork is sealed off.







FRIABLE AND NON-FRIABLE

Two classes of asbestos products were widely used in the past. The first includes materials easily crumbled or loose in composition. These are referred to as “friable.”

The second type includes materials much more durable because they are held together by a binder such as cement, vinyl, or asphalt. These products are termed “non-friable.”

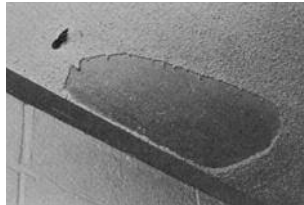
Friable material was widely used to fireproof steel structures. It can be found on beams, columns, trusses, hoists, and steel pan floors. Sprayed material was also used as a decorative finish and as acoustical insulation on ceilings.

The material can be loose, fluffy, and lumpy in texture or, if more gypsum was used, it may be quite hard and durable.

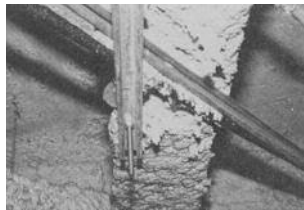
Friable Materials



Approved Fireproofing



Acoustical Coating



Sprayed Fireproofing



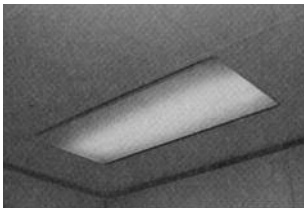
Air-Cell Pipe Insulation



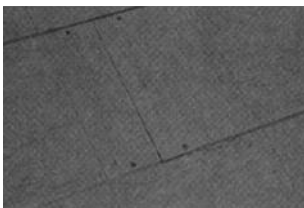
Non-Friable Materials



Suspended Ceiling Concealing Fireproofing



Asbestos-Cement Siding



Vinyl Asbestos Floor Tile

CERTIFICATION AND TRAINING

Certification: Type 3 operations

All workers who perform Type 3 asbestos operations—and the supervisors of these workers—must be certified to do their work. (Type 3 operations are discussed later in this chapter.) This certification requirement is contained in Ontario Regulation 278/05. There are two certification programs: one for workers and one for supervisors. Supervisors must complete both the worker program and the supervisor program. The certification programs must comply with the Ministry of Training, Colleges, and Universities’ training standards for the programs. Contact CSAO for details (1-800-781-2726).

Training for any “Type” of asbestos operation

Whenever work is planned at a location where asbestos is present, constructors and employers must inform workers about

- the location of asbestos-containing materials or materials assumed to contain asbestos
- whether the material is friable or non-friable, and
- the type of asbestos (e.g., chrysotile, amosite, tremolite, etc.) if the material is sprayed.

Constructors and employers must then ensure that workers are trained on asbestos hazards and controls as detailed on the next page.

Employers performing regular service or maintenance work on behalf of owners have these same training requirements. Such employers should develop safe work practices. They should also become familiar with the owner’s asbestos procedures and communicate them to their employees.



Content of training

All workers who perform a Type 3 asbestos operation, and the supervisors of the operation, must be certified to do their work. See the section on “Certification: Type 3 operations” on the previous page.

Workers in **any “Type”** of asbestos operation—as well as other workers who could be exposed to asbestos—must be trained by a competent person on the following:

- the hazards of asbestos exposure
- the purpose, inspection, maintenance, use, fitting, cleaning, disinfecting, and limitations of respirators
- personal hygiene and correct procedures for work with asbestos
- how to use, clean, and dispose of protective clothing.

Note: The above applies to facility owners and tenants whose staff undertake work involving the removal or disturbance of asbestos-containing material or who contract with other employees to do so.

Training should also include

- methods of recognizing asbestos, including identification of building materials that contain asbestos
- the relationship between smoking, asbestos, and lung cancer
- the kinds of operations that could result in exposure to asbestos
- classification of Type 1, Type 2, and Type 3 operations
- required work procedures and controls to minimize exposure, including engineering controls, work practices, respirators, housekeeping procedures, hygiene facilities, protective clothing, decontamination procedures, emergency procedures, and waste disposal procedures
- the requirements of the medical-surveillance program
- the requirements for signs and labels.

The joint health and safety committee or the health and safety representative must be informed about when and where the training will take place.

ENCAPSULATION OR REMOVAL

In dealing with asbestos that may be encountered in applications such as fireproofing and cement, the decision whether to encapsulate the material, remove it, or leave it in place rests with the client/owner.

Many owners of asbestos-containing buildings have decided to reduce the risk of exposure to asbestos. The procedure is normally either removal or encapsulation. Encapsulation means spraying an approved sealant onto or into the material to prevent the release of fibres into the air in the building.

Encapsulation is permitted only if the asbestos will not be damaged further in the process.

Removal of asbestos is a more permanent solution to the problem. Most removal projects employ the **wet removal** method. Water and a wetting agent are sprayed onto the asbestos. This effectively reduces the quantity of fibres released when the material is removed.

Dry removal is normally done only when wet removal is unsafe or impractical – for instance in computer rooms or other areas where there is a chance of water damage to delicate equipment. Dry removal causes excessively high concentrations of asbestos fibres (in excess of 100 fibres per cubic centimetre) and may contaminate other previously “clean” areas.

During dry removal projects, use an extensive filtered exhaust system to create a slight negative air pressure in the work area. This will reduce the chance of spreading asbestos fibres. The requirements for negative air pressure are specified in the asbestos regulation.

Another solution is to enclose the asbestos with a physical barrier such as drywall. This is normally done where the area is not going to be entered frequently or altered later.

The asbestos regulation specifies what precautions must be taken during removal, encapsulation, or enclosure.



Spraying Asbestos Ceiling Material with Amended Water Before Wet Removal

TYPES

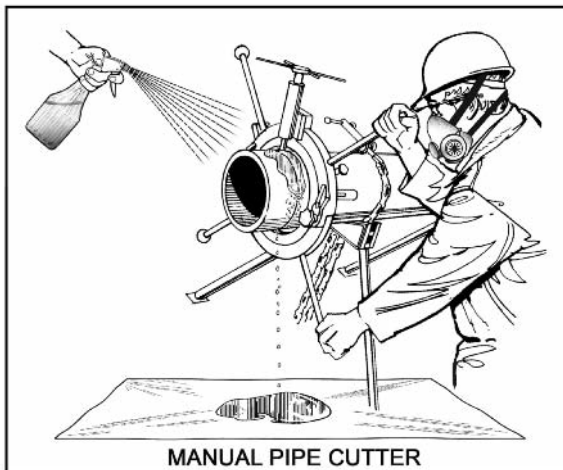
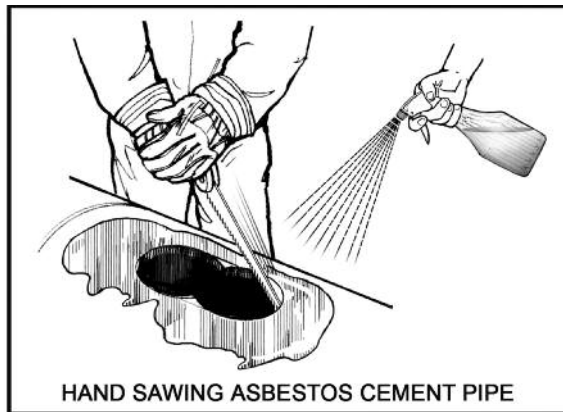
Under Ontario law, asbestos operations are classified as Type 1, Type 2, or Type 3.

Type 1 – generally presents little hazard to workers or bystanders (for example, hand removal of vinyl asbestos tile).

Type 2 – may create exposure exceeding acceptable limits (for example, removing six square inches of asbestos fireproofing to attach a new pipe hanger).

Type 3 – major exposures, exceeding acceptable limits, involving frequent or prolonged exposure, and posing serious risks to both workers and to bystanders (for example, full-scale removal of sprayed asbestos fireproofing in an occupied building).

Ontario Regulation 278/05 (*Designated Substance—Asbestos on Construction Projects and in Buildings and Repair Operations*) outlines safe work procedures and respiratory protection for workers who may encounter asbestos in the course of their work. CSAO also produces a manual called *Asbestos: Controls for Construction, Renovation, and Demolition* (DS037). It shows how workers can protect themselves. The manual also describes correct procedures for asbestos operations, and helps employers and constructors understand their legal responsibilities.



TYPE 1 OPERATIONS

Type 1 operations include the following:

- 1) Installing or removing less than 7.5 square metres of ceiling tile containing asbestos (81 square feet, or ten 4-foot x 2-foot ceiling tiles) without it being broken, cut, drilled, abraded, ground, sanded, or vibrated.
- 2) Installing or removing non-friable asbestos-containing material, other than ceiling tiles, without it being broken, cut, drilled, abraded, ground, sanded, or vibrated.
- 3) Breaking, cutting, drilling, abrading, grinding, sanding, or vibrating non-friable asbestos-containing material if
 - a) you wet the material, and
 - b) you use only non-powered hand-held tools.
- 4) Removing less than one square metre of drywall where asbestos joint-filling compound was used (see shaded box on next page).

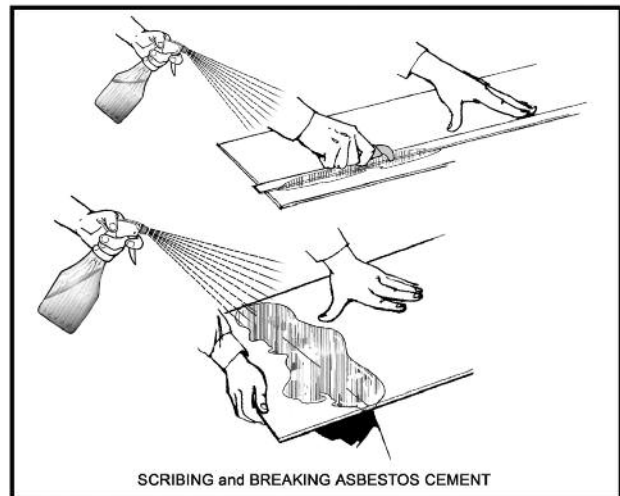
If these operations are done properly, it is unlikely that exposure will exceed acceptable limits.

See the respirator selection chart at the end of the chapter to determine the respirator you require. You must also follow the control procedures described in Ontario Regulation 278/05. See CSAO's asbestos manual (DS037) for details.

Wetting agent

Water alone is not sufficient to control dust and fibres. You must add a "wetting agent" to reduce the water's surface tension. This increases the water's ability to penetrate material and get into nooks and crannies.

To make this "amended water," you can use ordinary dishwashing detergent: 1 cup detergent for every 20 litres of water.

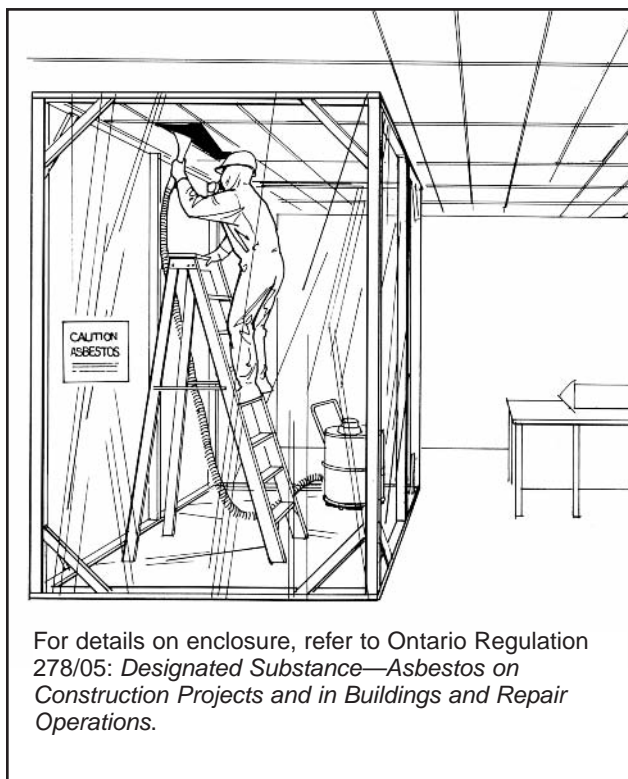


TYPE 2 OPERATIONS

Exposure to asbestos is likely in Type 2 operations. You need controls to protect workers and others nearby.

Type 2 operations include the following:

- 1) Removing all or part of a false ceiling in buildings containing sprayed asbestos fireproofing if it is likely that asbestos dust is resting on top of the ceiling. This is likely when fireproofing is deteriorating or damaged.



- 2) Removing or disturbing less than 1 square metre of friable asbestos materials—for example, repairing an insulated pipe joint or removing some fireproofing to fasten a new pipe hanger.
- 3) Enclosing friable asbestos insulation to prevent further damage or deterioration.
- 4) Applying tape, sealant, or other covering (by means other than spraying) to pipe or boiler insulation.
- 5) Installing or removing more than 7.5 square metres of ceiling tile containing asbestos, without it being broken, cut, drilled, abraded, ground, sanded, or vibrated.
- 6) Breaking, cutting, drilling, abrading, grinding, sanding, or vibrating non-friable asbestos-containing material if the material is not wetted and the work is done only with non-powered hand-held tools.

- 7) Removing one square metre or more of drywall where the joint-filling compound contains asbestos.

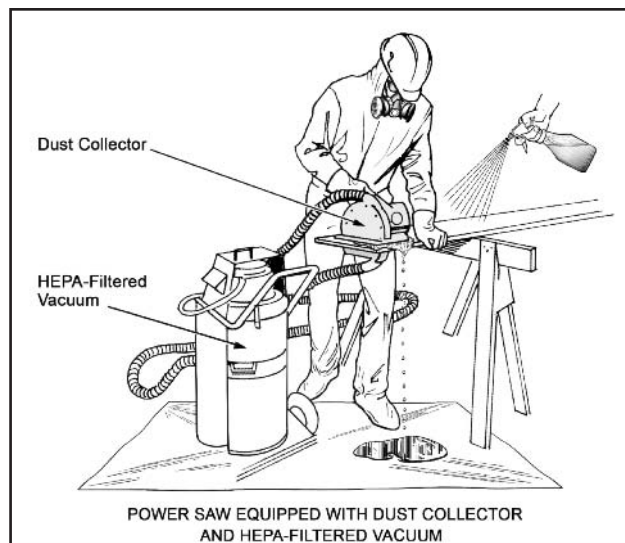
Note: The classification of drywall compound removal is being reviewed. Please check with the Ministry of Labour.

Drywall joint-filling compound

Early drywall joint-filling compounds contained significant amounts of asbestos fibre. This particular use was specifically prohibited in 1980. Still, it may be found in buildings constructed several years afterwards.

- 8) Working on non-friable asbestos with power tools that are attached to dust-collecting devices equipped with HEPA filters. If you need to power-grind or machine the asbestos product and your tools are not equipped with HEPA-filtered dust collectors, refer to CSAO's *Asbestos: Controls for Construction, Renovation, Demolition*, Section 12.9.

To prevent electric shock, any power tools used around water must be equipped with a ground fault circuit interrupter (GFCI) and be maintained properly.



- 9) Using a glove bag to remove asbestos-containing materials from pipes, ducts, or similar structures.
- 10) Cleaning or removing filters used in air-handling equipment in a building with sprayed asbestos fireproofing.
- 11) An operation that is not Type 1 or Type 3.

See the respirator selection chart at the end of the chapter to determine the respirator you require. You must also follow the control procedures described in Ontario Regulation 278/05. See CSAO's asbestos manual (DS037) for details.

TYPE 3 OPERATIONS

These operations require the most precautions because they can release substantial amounts of asbestos dust.

Every worker and supervisor involved in a Type 3 operation must be certified to do their work. See the section on “Certification and Training” earlier in this chapter.

Type 3 operations include the following:

- 1) Removing or disturbing more than 1 square metre of friable asbestos-containing material.
- 2) Spraying a sealant onto friable asbestos material.
- 3) Cleaning or removing air-handling equipment in buildings with sprayed asbestos fireproofing.
- 4) Repair, alteration, or demolition of kilns, metallurgical furnaces, and other installations with asbestos refractory materials.
- 5) Disturbing non-friable asbestos material in any way with power tools not equipped with dust collectors and HEPA vacuums.
- 6) Repair, alteration, or demolition of buildings which are or were used to manufacture asbestos products unless the asbestos was cleaned up and removed before March 16, 1986.

See the respirator selection chart at the end of the chapter to determine the respirator you require. You must also follow the control procedures described in Ontario Regulation 278/05. See CSAO’s asbestos manual (DS037) for details.

ASBESTOS WASTE MANAGEMENT

The off-site handling and disposal of asbestos waste is governed by the *Environmental Protection Act*. Regulations regarding the transportation of dangerous goods under either Transport Canada (federal) or the Ontario Ministry of Transportation may also apply.

Some municipalities may not accept asbestos waste at landfill operations. Contractors are urged to check with local authorities for the nearest disposal site and with the district office of the Ministry of the Environment.

CAUTION
CONTAINS ASBESTOS FIBRES
AVOID SPILLING AND CREATING DUST

ASBESTOS MAY BE HARMFUL TO YOUR HEALTH

IN CASE OF SPILL,

- wear (as a minimum) a NIOSH-approved N-100, R-100, or P-100 respirator
- wear disposable coveralls and boot coverings
- **DO NOT DRY SWEEP.** Wet material thoroughly, place it in a plastic bag, and seal bag
- damp-wipe or HEPA-vacuum exposed surfaces and clothing after clean-up
- wash hands and face, or take a shower, after clean-up.

IN CASE OF SPILL, CALL:

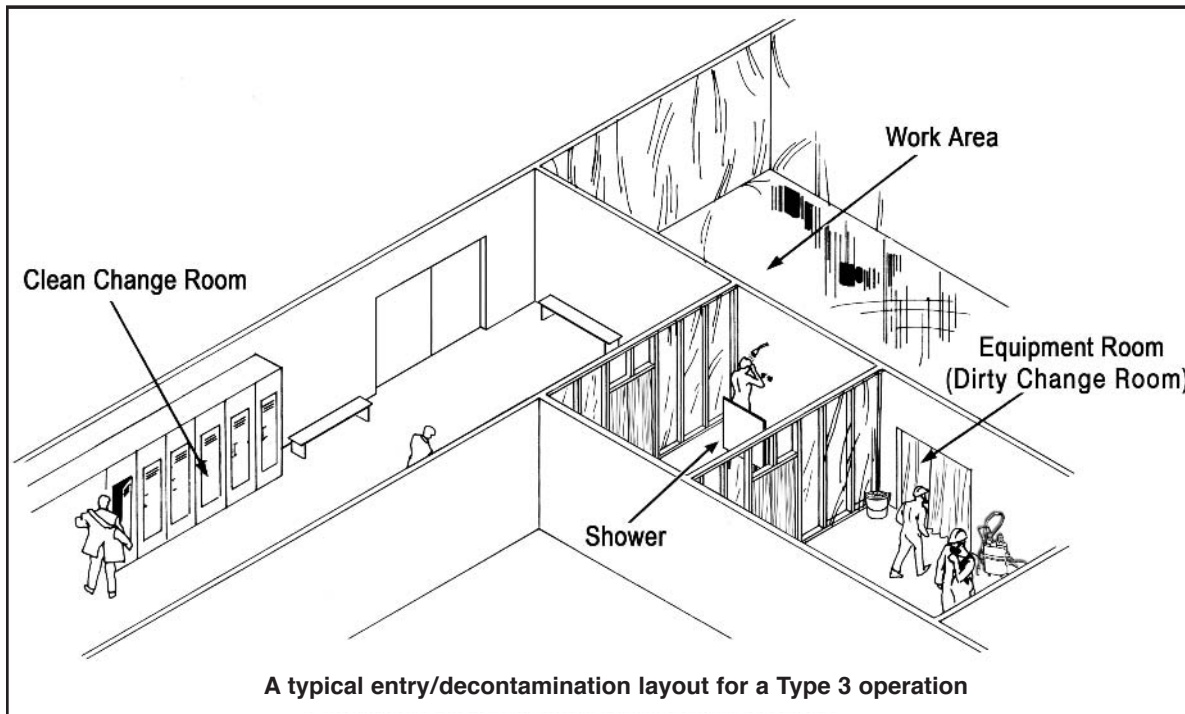
Construction Safety Association of Ontario
 1-800-781-2726 Fax: (416) 674-8888
 info@csao.org www.csao.org

5035

EQUIVALENT MEASURES AND PROCEDURES

A contractor may use measures and procedures other than those described in this chapter if the proposed measures and procedures offer the same or better protection for workers.

A written notice of this variance must be given in advance to the joint health and safety committee or the health and safety representative for the workplace.



RESPIRATOR CHART FOR ASBESTOS WORK

“ACM” means asbestos-containing material.

Description of work		Required respirator
Type 1 operations		
All Type 1 operations		If worker asks employer to provide a respirator: A
Type 2 operations		
Removing all or part of a false ceiling to obtain access to a work area, if ACM is likely to be lying on the surface of the false ceiling.		B
Breaking, cutting, drilling, abrading, grinding, sanding, or vibrating non-friable ACM if the work is done by means of power tools that are attached to dust-collecting devices equipped with HEPA filters.	Material is not wetted	B
	Material is wetted to control fibres	A
All other Type 2 operations*		A
Type 3 operations		
Breaking, cutting, drilling, abrading, grinding, sanding, or vibrating non-friable ACM using power tools, if the tool is not attached to a dust-collecting device equipped with a HEPA filter.	Material is not wetted	C
	Material is wetted to control fibres	B
<ul style="list-style-type: none"> ➤ Removing or disturbing more than one square metre of friable ACM during the repair, alteration, maintenance, or demolition of all or part of a building, aircraft, ship, locomotive, railway car or vehicle, or any machinery or equipment. ➤ Spraying sealant on friable ACM. ➤ Cleaning or removing air-handling equipment, including rigid ducting but not including filters, in a building where sprayed fireproofing is ACM. ➤ Repairing, altering, or demolishing all or part of a kiln, metallurgical furnace, or similar structure that is made in part of refractory ACM. ➤ Repairing, altering, or demolishing all or part of any building in which asbestos is or was used in the manufacture of products, unless the asbestos was cleaned up and removed before 16 March 1986. 	Material is not wetted	D
	Friable ACM other than chrysotile was applied or installed by spraying, and is wetted to control fibres	C
	Friable chrysotile ACM was applied or installed by spraying, and is wetted to control fibres	B
	Friable ACM was not applied or installed by spraying, and is wetted to control fibres	B

* **Warning:** For any **Type 2** operation in which wetting is required but would cause a greater hazard or damage, then dry work is permitted. Dry work, however, usually results in more airborne fibres. CSAO recommends that you select a category B respirator (see below).

KEY TO RESPIRATOR CHART

A	B	C	D
Air-purifying half-mask respirator with N-100, R-100, or P-100 particulate filter. If the worker requests the respirator from the employer, then the worker must wear it.	Choose any of the following: <ul style="list-style-type: none"> ➤ Air-purifying full-facepiece respirator with N-100, R-100, or P-100 particulate filter. ➤ Powered air-purifying respirator with a tight-fitting facepiece (either full or half facepiece) and a high-efficiency filter. ➤ Negative-pressure (demand) supplied-air respirator with a full facepiece. ➤ Continuous-flow supplied-air respirator with a tight-fitting facepiece (full or half facepiece). 	Pressure-demand supplied-air respirator with a half facepiece.	Pressure-demand supplied-air respirator with a full facepiece.

Disposable respirators or dust masks are not recommended for avoiding exposure to asbestos fibres because it's difficult to perform negative-pressure and positive-pressure seal checks.

35 WATER AND ICE

Construction over and around water and ice presents special dangers. Precautions specifically developed for such construction must be taken before work begins.

This chapter outlines general safeguards that must be followed whenever personnel are required to work over water or on ice, including construction on bridges, wharves, dams, locks, and breakwaters.

Guardrails

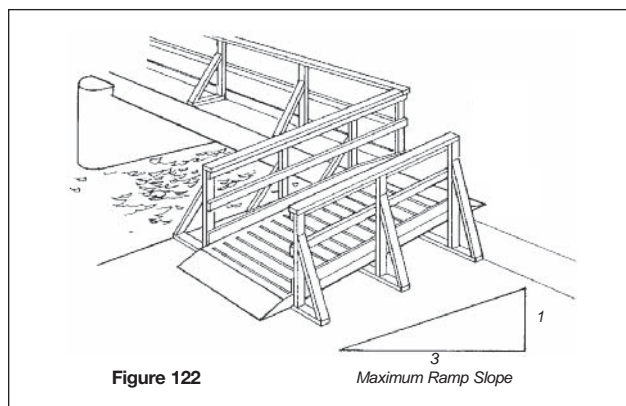
The requirements for guardrails specified in this manual and in Section 26 of the Construction Regulation apply to work stations over water or ice.

Ramps

Ramps must be

- at least 46 centimetres (18 inches) wide
- not sloped more than 1 in 3 (20 degrees) and
- where slope exceeds 1 in 8 (6 degrees), have cleats 19 x 38 millimetres (1 inch by 2 inches) secured at regular intervals not more than 50 centimetres (20 inches) apart.

When a ramp is used for equipment such as wheelbarrows and a worker may fall from the ramp a distance of 1.2 metres (4 feet) or more — or may fall any distance into water — the ramp must be provided with guardrails (Figure 122).



Floating Work Platforms

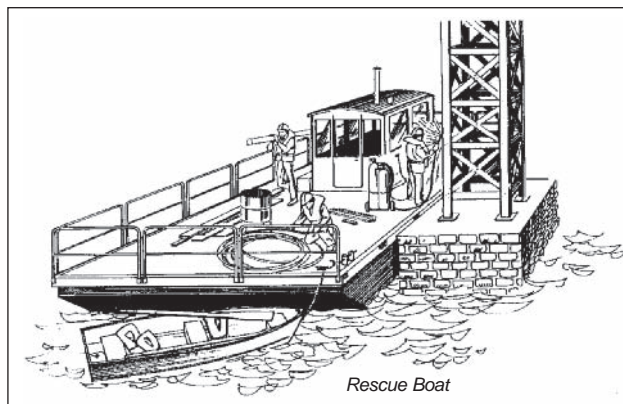
When used on a construction project, rafts, scows, and similar vessels are considered work platforms. As such, they are subject to certain requirements.

- Guardrails must be provided along open edges. The guardrails may be removed at the working side of the platform, provided workers are protected by alternate measures of fall protection.
- Workers on floating platforms must wear lifejackets. A lifejacket provides enough buoyancy to keep the

wearer's head above water, face up, without effort by the wearer.

- Appropriate rescue measures must be prepared.

In addition, the positioning and securing of vessels used as work platforms should be supervised and undertaken by experienced personnel.

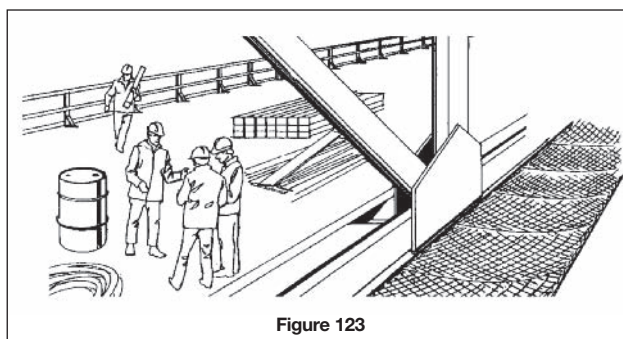


Fall-Arrest Systems

The requirements specified in the chapters on Guardrails and Personal Fall Protection in this manual apply to work over water or ice.

Safety Nets

Safety nets may be necessary when structural design, loading access, worker mobility, or other factors make guardrails and fall-arrest systems impractical (Figure 123).



Safety nets must be

- designed, tested, and installed in accordance with ANSI Standard 10.11-1989, *Personnel and Debris Nets for Construction and Demolition Operations*
- installed by a competent worker
- inspected and tested by a professional engineer or competent person under the engineer's supervision before the net is put into service.

The engineer must document the inspection and testing of the safety net and sign and seal the document. A copy of the document must be kept at the project while the safety net is in service.

Lifejackets and PFDs

A PFD is a personal flotation device.

A **lifejacket** is a PFD that provides buoyancy adequate to keep the wearer's head above water, face up, without effort by the wearer.

Other PFDs do not provide this protection. Some provide flotation only.

Lifejackets must be worn by workers exposed to the danger of drowning in water deep enough for the lifejacket to be effective. Workers must use an approved lifejacket when travelling on water or while at a project over or adjacent to water.

For boating to and from the worksite, boats must be equipped with one approved lifejacket for each person on board.

“Approved” refers to approval by Transport Canada (look for the Transport Canada label).

Rescue

Where personnel are exposed to the risk of drowning, at least two workers **trained to perform** rescue operations must be available for a rescue operation. A seaworthy boat must also be available and furnished with the following rescue equipment (minimum):

- a ring buoy attached to 15 metres (50 feet) of polypropylene rope 9.5 millimetres (3/8 inch) in diameter
- a boat hook
- lifejackets for each person in the rescue crew.

Where a manually-operated boat is not suitable or where the water is likely to be rough or swift, the rescue boat must be power-driven. The engine should be started and checked daily.

Rescue equipment such as boats must be stored on or near the project, ready for use.

Where there is a current in the water, a single length of line must be extended across the water downstream from all work locations and be fitted with buoys or similar floating objects that are capable of providing support for a person in the water. The line must be securely fastened at each end to adequate anchorage.

An alarm system must be installed and maintained to alert workers to the need for an emergency rescue.

All of these requirements are illustrated in Figure 125.

Transporting Workers by Boat

When navigating any Canadian waterway, boats and other floating vessels must comply with the requirements of the *Canada Shipping Act*. Refer specifically to the *Small Vessel Regulations* (Section 16.02) and *Collision Regulations* under the Act.

Commonly, boats used for construction operations are not longer than 6 metres (19'8"). Boats in this class must be equipped with at least

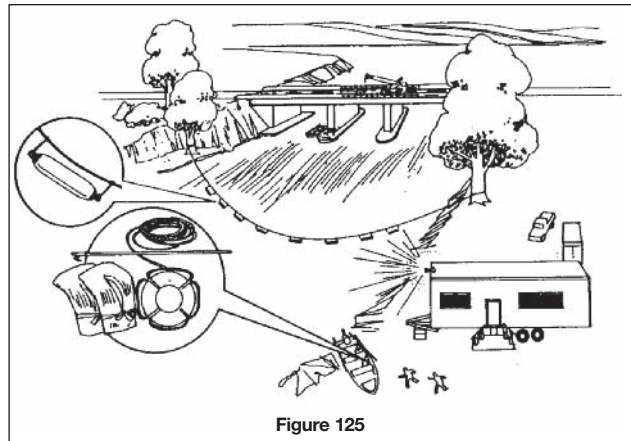


Figure 125

- one approved lifejacket for each person on board
- one paddle or an anchor with at least 15m of cable, rope, or chain
- one bailer or one manual pump
- one Class 5BC fire extinguisher if the craft has an in-board engine, fixed fuel tank, or fuel-burning appliance
- one sound signalling device.

All powerboats require some navigation lights if operated after sunset or before sunrise. For appropriate regulations, consult the *Safe Boating Guide* published by the Canadian Coast Guard, or the *Canada Shipping Act – Small Vessel Regulations* and applicable standards set out in the *Collision Regulations* under the Act.

Ice Testing

Work, travel, and parking on frozen bodies of water should be avoided whenever possible and be done only as a last resort. The ice **must** be tested before any workers or vehicles are allowed onto the surface. Loads that may safely travel on ice may not necessarily be left on ice for extended periods of time. This applies especially to parked vehicles.

Before testing, learn as much as possible about ice conditions from local residents. Testing requires at least two persons on foot proceeding with caution. Each person must wear an approved lifejacket or, preferably, an approved floatable survival suit that protects against hypothermia.

For ice testing, a survival suit or lifejacket is required because a person falling into frigid water may lose consciousness and the suit or lifejacket will keep the person's face out of the water.

Members of the ice-testing crew should stay about 10 metres (30 feet) apart. The lead member must wear a safety harness attached to a polypropylene rescue rope 9.5 millimetres (3/8 inch) thick, at least 20 metres (65 feet) long, and held by the trailing crew member (Figure 127).

Clear blue ice is the most desirable for strength. White or opaque ice forms from wet snow and has a higher air content. It is less dense and therefore weaker than clear blue ice. Grey ice indicates the presence of water from thawing and should not be trusted as a load-bearing surface.

The lead crew member should cut test holes every 8 metres (25 feet) or so. If ice is less than 10 centimetres (4 inches) thick, the lead and trailing crew members should vacate the area immediately.

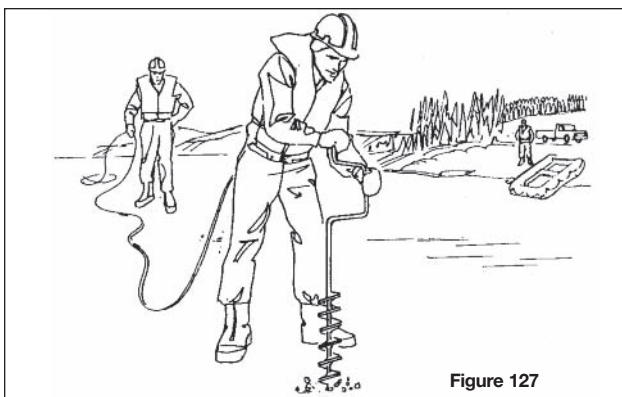


Figure 127

The biggest uncertainty about the load-bearing capacity of ice is the natural variation in thickness and quality that can occur over a given area. Currents and springs can cause variations in thickness without changing the overall surface appearance of the ice. Considerable variation in ice thickness can occur where rivers have significant currents or high banks. Similar situations occur in lakes at the inlet and outlet of rivers.

Only the thickness of continuously frozen ice should be used to determine bearing capacity. The basis for capacity should be the **minimum** thickness measured.

In addition to testing for thickness, crews should check ice for cracking.

Ice thickness (Figure 128) is determined by the full thickness of clear blue ice plus half the thickness of any white, continuously frozen ice (source: *Safety Guide for Operations Over Ice*, Treasury Board of Canada).

For repeated work or travel over ice, the surface must be tested regularly to ensure continued safety. Ice must also be tested regularly near currents or eddies and around permanent structures like abutments.

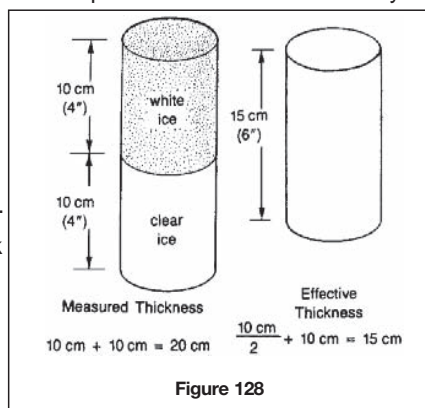


Figure 128

Bearing Capacity of Ice

Where heavy equipment such as cranes or structures such as concrete forms are to be placed on ice for extended periods, ask an experienced consultant for advice on bearing capacity, load methods, and inspection procedures. With professional advice it is possible to increase bearing capacity considerably. But careful control is required over surface operations, loading procedures, and ice monitoring.

In other cases, refer to Graph 1 for allowable **moving** loads on various thicknesses of clear blue ice. Remember: the graph is **not** to be used for loads parked, stored, or otherwise left stationary for long periods of time.

Certain types of cracking can affect the bearing capacity of ice. For a single dry crack wider than 2.5 centimetres (1 inch), reduce loads by one third; for intersecting cracks of this size, reduce loads by two thirds. Dry cracks can be repaired by filling in with water or slush.

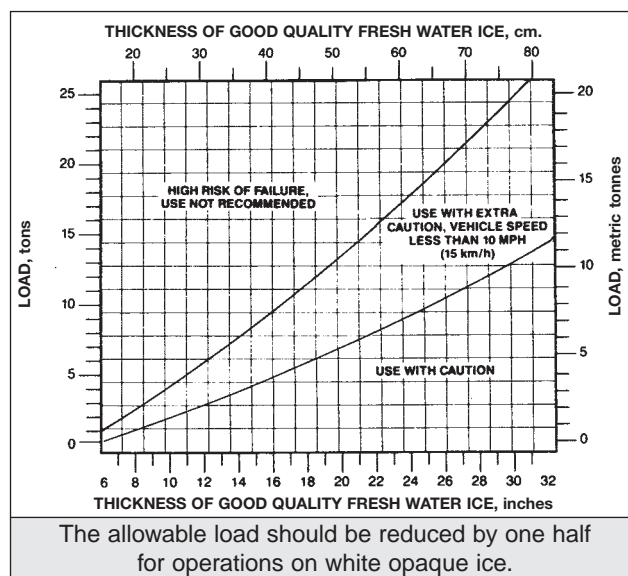
A wet crack indicates penetration through the ice to water below. Bearing capacity can be dangerously lowered. For a single wet crack, reduce loads by three quarters. Most wet cracks refreeze as strong as the original ice. A core sample should be taken to determine the depth of healing.

Other Considerations

- Ice roads must be at least 40 centimetres (16 inches) thick along their entire length and should be clearly marked.
- Ice roads should not be built up more than 10 centimetres (4 inches) in one day and must not be used or reflooded until the top layer has completely frozen.
- While an ice road is in use it must be checked daily for thickness, cracks, thawing, and other conditions.
- All rescue equipment listed earlier in this chapter must be readily available.
- A life ring attached to 20 metres (65 feet) of polypropylene rescue rope 9.5 millimetres (3/8 inch) thick must be kept within 35 metres (115 feet) of the work area.
- A warm place such as a truck cab or hut must be provided and made known to personnel near the worksite.

For more information on the bearing capacity of ice, see *Safety Guide for Operations Over Ice*, by the Treasury Board of Canada.

Recommended Bearing Capacity Based on Experience — Moving Loads Only



The allowable load should be reduced by one half for operations on white opaque ice.

Graph 1 Courtesy Treasury Board of Canada

Ice thickness versus ice strength

This table provides the safe load for a given ice thickness of

- fresh ice (lake and river ice) and
- sea ice (St. Lawrence River, Gulf of St. Lawrence, etc.)

SAFE LOAD	OPERATION	FRESH ICE	SEA ICE
One person	at rest	8 cm	13 cm
0.4 ton	moving slowly	10 cm	18 cm
10 ton tracked vehicle	moving slowly	43 cm	66 cm
13 ton aircraft	parked	61 cm	102 cm

Table provided by the National Research Council of Canada.

Tools and Techniques

36 HAND TOOLS

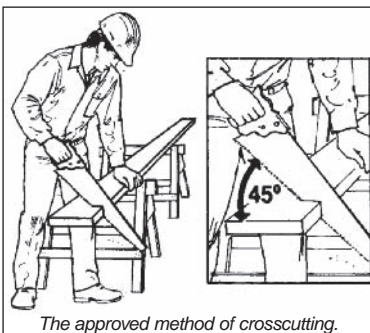
Injuries with hand tools are not often serious but they do involve lost time. Common causes include using the wrong tool, using the right tool improperly, haste, and lack of training or experience.

Hand Saws

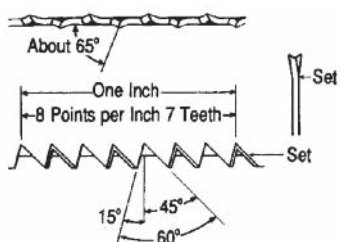
Select the right saw for the job.

A 9 point is not meant for crosscutting hardwood. It can jump up and severely cut the worker's hand or thumb.

For this kind of work the right choice is an 11 point (+). When starting a cut, keep your thumb up high to guide the saw and avoid injury.



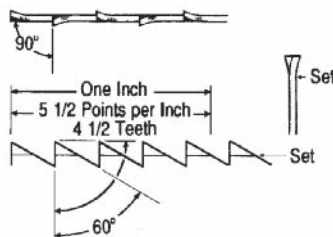
The side and tooth-edge views of a typical crosscut saw. This saw is used for cutting across the grain and has a different cutting action than that of the rip saw. The crosscut saw cuts on both the forward and backward strokes.



For cutting softwood, select a 9 point (-). The teeth will remove sawdust easily and keep the saw from binding and bucking.

Ripping requires a rip saw. Check the illustrations for the differences in teeth and action between rip and crosscut saws.

The side and tooth-edge views of a typical rip saw. This saw is used for cutting with the grain. Cutting is done only on the forward stroke.



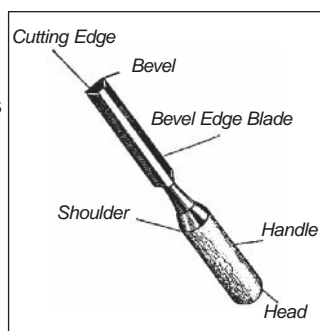
Wood Chisels

Most injuries with this tool can be prevented by keeping the hand that holds the work **behind**, not in front of, the chisel.

A dull or incorrectly sharpened chisel is difficult to control and tedious to work with.

Chisels not in use or stored in a toolbox should have protective caps.

Wood chisels are tempered to be very hard. The metal is brittle and will shatter easily against hard surfaces.



Never use a chisel for prying.

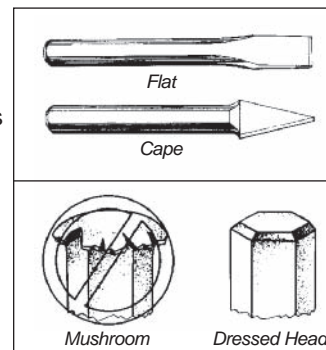
Repeatedly striking the chisel with the palm of your hand may lead to repetitive strain injury.

With chisels and other struck tools, **always wear eye protection**. Gloves are recommended to help prevent cuts and bruises.

Cold Chisels

Cold chisels are used to cut or shape soft metals as well as concrete and brick.

In time the struck end will mushroom. This should be ground off. Don't use chisels with mushroomed heads. Fragments can fly off and cause injury.

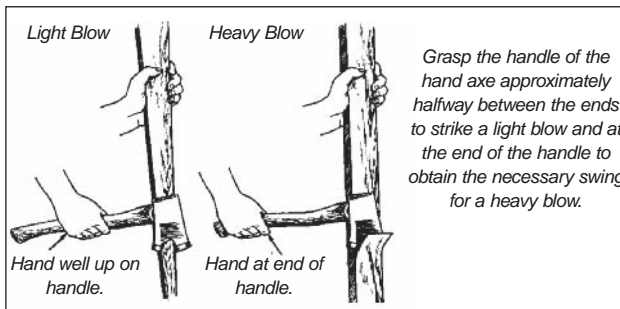
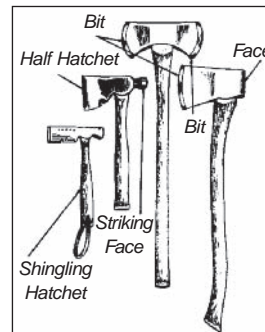


Axes and Hatchets

In construction, axes are mainly used for making stakes or wedges and splitting or shaping rough timbers.

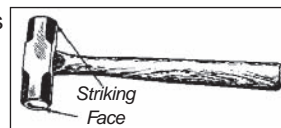
Unless it has a striking face, don't use the hatchet as a hammer. The head or the wooden handle can crack and break.

Hatchets with striking faces are meant only for driving common nails, not for striking chisels, punches, drills, or other hardened metal tools.



Never use an axe or hatchet as a wedge or chisel and strike it with a hammer.

Most carpenters prefer a hatchet with a solid or tubular steel handle and a hammer head with a slot for pulling nails.



Sledgehammers

Sledgehammers are useful for drifting heavy timbers and installing and dismantling formwork. They can knock heavy panels into place and drive stakes in the ground for bracing.

Sledgehammers can also be used to drive thick tongue-and-groove planking tightly together. Use a block of scrap wood to prevent damage to the planks.

The main hazard is the weight of the head. Once the hammer is in motion it's almost impossible to stop the swing. Serious bruises and broken bones have been caused by sledgehammers off-target and out of control.



Hammer On Target

Missing the target with the head and hitting the handle instead can weaken the stem. Another swing can send the head flying.

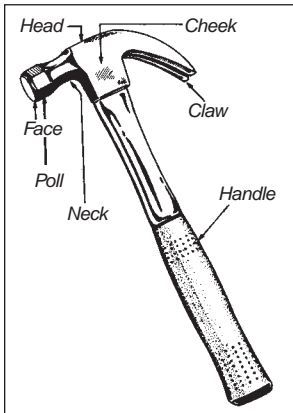
Always check handle and head. Make sure head is secure and tight. Replace damaged handles.

As with any striking or struck tool, always wear eye protection.

Swinging a sledgehammer is hard work. Avoid working to the point of fatigue. Make sure you have the strength to maintain aim and control.

Claw Hammers

These are available in many shapes, weights, and sizes for various purposes. Handles can be wood or steel (solid or tubular). Metal handles are usually covered with shock-absorbing material.



Caution: Repeated use of a hammer may lead to musculoskeletal injury, strain, or carpal tunnel syndrome. Exercising to warm up, as well as to develop and maintain overall muscle condition, may help to reduce the risk of strain or injury.

Start with a good quality hammer of medium weight (16 ounces) with a grip suited to the size of your hand.

Rest your arm occasionally to avoid tendinitis. Avoid overexertion in pulling out nails. Use a crow bar or nail puller when necessary.

When nailing, start with one "soft" hit, that is, with fingers holding the nail. Then let go and drive the nail in the rest of the way.

Strike with the hammer face at right angles to the nailhead. Glancing blows can lead to flying nails. Clean the face on sandpaper to remove glue and gum.

Don't use nail hammers on concrete, steel chisels, hardened steel-cut nails, or masonry nails.

Discard any hammer with a dented, chipped, or mushroomed striking face or with claws broken, deformed, or nicked inside the nail slot.

Utility Knives

Utility knives cause more cuts than any other sharp-edged cutting tool in construction.

Use knives with retractable blades only.

Always cut away from your body, especially away from your free hand. When you're done with the knife, retract

the blade at once. A blade left exposed is dangerous, particularly in a toolbox.

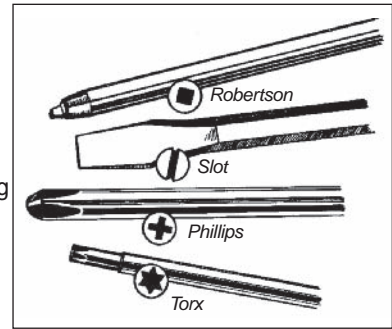
Screwdrivers

More than any other tool, the screwdriver is used for jobs it was never meant to do.

Screwdrivers are not intended for prying, scraping, chiselling, scoring, or punching holes.

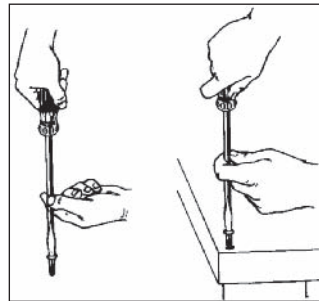
The most common abuse of the screwdriver is using one that doesn't fit or match the fastener. That means using a screwdriver too big or too small for the screw or not matched to the screw head.

The results are cuts and punctures from slipping screwdrivers, eye injuries from flying fragments of pried or struck screwdrivers, and damaged work.



Always make a pilot

hole before driving a screw.

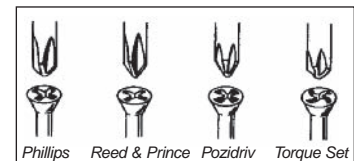


Start with one or two "soft" turns, that is, with the fingers of your free hand on the screw. Engage one or two threads, make sure the screw is going in straight, then take your fingers away.

You can put your fingers on the shank to help guide

and hold the screwdriver. But the main action is on the handle, which should be large enough to allow enough grip and torque to drive the screw. Power drivers present obvious advantages when screws must be frequently or repeatedly driven.

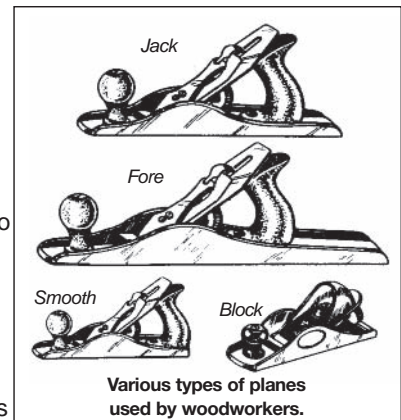
Note: All cross-point screws are not designed to be driven by a Phillips screwdriver. Phillips screws and drivers are only one type among several crosspoint systems. They are **not** interchangeable.



Hand Planes

Hazards include the risk of crush and scrape injuries when the hand holding the plane strikes the work or objects nearby. Cuts and sliver injuries are also common.

The hand plane requires some strength and elbow grease to use properly. The hazards



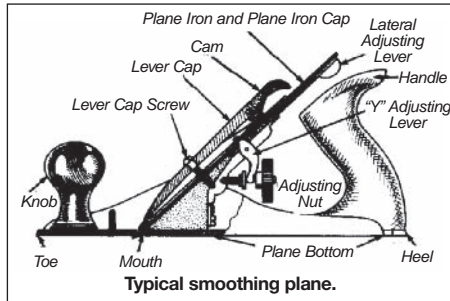
Various types of planes used by woodworkers.

of overexertion and tendinitis can be aggravated by using a dull iron or too short a plane.

Use the plane suited to the job and keep the iron sharp.

For long surfaces like door edges, use a fore plane 18" long and 2 3/8" wide or a jointer plane 24" long and 2 5/8" wide.

For shorter surfaces, use a jack plane 15" long and 2 3/8" wide or a smoothing plane 10" long and 2 3/8" wide.



Remember that sharp tools

require less effort and reduce the risk of fatigue, overexertion, and back strain.

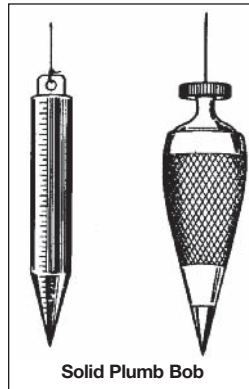
Work can also be easier with a door jack (page 182) and supports on your work bench.

Plumb Bobs

The weight of a mercury-filled plumb bob will surprise you. Designed for use in windy conditions, the bob has considerable weight in proportion to its surface area.

The weight and point of the bob can make it dangerous. Ensure that all is clear below when you lower the bob.

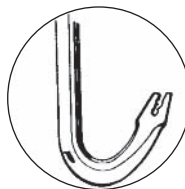
Don't let it fall out of your pocket, apron, or tool bag. The same goes for the standard solid bob.



Crow Bars

Any steel bar 25-150 cm long and sharpened at one end is often called a crow bar.

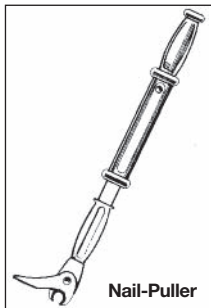
The tools include pry bars, pinch bars, and wrecking bars. Shorter ones usually have a curved claw for pulling nails and a sharp, angled end for prying.



Nail Pulling

Pulling out nails can be easier with a crow bar than a claw hammer.

In some cases, a nail-puller does the job best. Keep the hand holding the claw well away from the striking handle.



Lifting

Loads levered, lifted, or shifted by bars can land on fingers and toes.

- Make sure to clear the area and maintain control of the load.
- Have enough rollers and blocking ready.

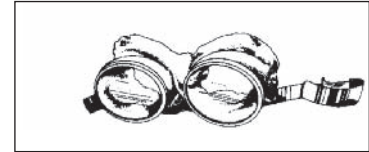
- Never – not even for a split second – put fingers or toes under the load.

General

Try to avoid prying, pulling, wedging, or lifting at sharp angles or overhead.

Wherever possible, keep the bar at right angles to the work.

Wear eye protection and, where necessary, face protection.



37 POWER TOOLS — DRILLS, PLANES, ROUTERS

Safety Basics

- Make sure that electric tools are properly grounded or double-insulated.
- Never remove or tamper with safety devices.
- Study the manufacturer's instructions before operating any new or unfamiliar electric tool.
- Regulations require that ground fault circuit interrupters (GFCIs) be used with any portable electric tool operated outdoors or in wet locations.
- Before making adjustments or changing attachments, always disconnect the tool from the power source.
- When operating electric tools, always wear eye protection.
- When operating tools in confined spaces or for prolonged periods, wear hearing protection.
- Make sure that the tool is held firmly and the material properly secured before turning on the tool.

Drills

Types

With suitable attachments, the drill can be used for disk sanding, sawing holes, driving screws, and grinding. However, when such applications are repeatedly or continuously required, tools specifically designed for the work should be used.

Trim carpenters will generally select a 1/4 or 3/8 inch trigger-controlled variable speed drill (Figure 129). Simply by increasing pressure on the trigger, the operator can change drill speed from 0 to 2,000 rpm.

Carpenters working in heavy structural construction such as bridges, trusses, and waterfront piers will usually select the slower but more powerful one- or two-speed reversible 1/2 or 3/4 inch drill (Figure 130a).

Size of the drill is determined by the maximum opening of the chuck. For instance, a 3/8 inch drill will take only bits or attachments with a shank up to 3/8 inch wide.

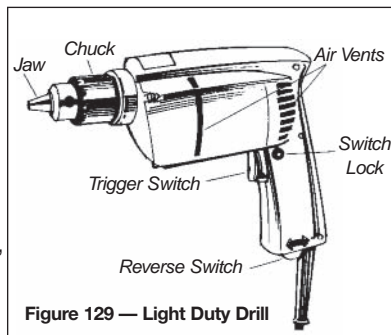


Figure 129 — Light Duty Drill

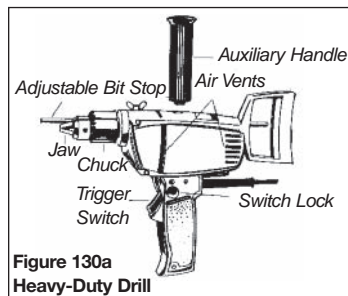


Figure 130a
Heavy-Duty Drill

used. The driving bit should be replaced when worn. Select a gun that can hang from your tool belt so it does not have to be continuously hand-held.

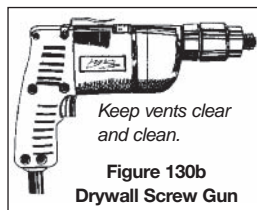


Figure 130b
Drywall Screw Gun

For drywall screws, a drywall screw gun (Figure 130b) should be

Attachments

Attachments such as speed-reducing screwdrivers, disk sanders, and buffers (Figure 131) can help prevent fatigue and undue muscle strain. A right-angle drive attachment (Figure 132) is very useful in tight corners and other hard-to-reach places.

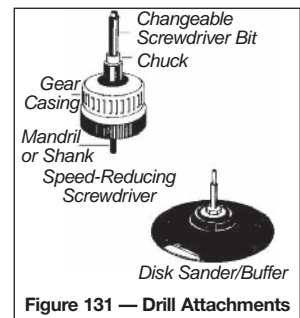


Figure 131 — Drill Attachments

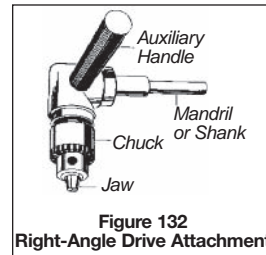


Figure 132
Right-Angle Drive Attachment

Cutting and drilling attachments must be kept sharp to avoid overloading the motor.

Operators should not crowd or push the tool beyond capacity. Such handling can burn out the motor, ruin the material, and injure the operator in the event of a kickback.

Some attachments, such as hole saws, spade bits, and screwdrivers (Figure 133), require considerable control by the operator. If the operator does not feed the attachment slowly and carefully into the material, the drill can suddenly stop and severely twist or break the operator's arm. Stock should be clamped or otherwise secured to prevent it from moving. This will also enable the operator to control the tool with both hands and absorb sudden twists or stops caused by obstructions such as knots or hidden nails.

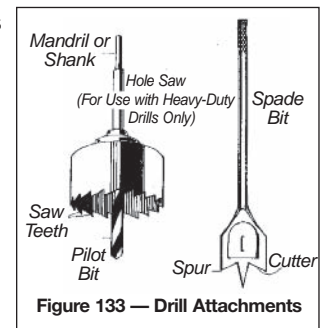


Figure 133 — Drill Attachments

Operators must restrain the drill just before the bit or cutting attachment emerges through the material, especially when oversized spade bits are used. Sides of the bit often become hooked on the ragged edge of the nearly completed hole and make the drill come to a sudden stop that can wrench the operator's arm.

At the first sign of the bit breaking through the material, the operator should withdraw the drill and complete the work from the other side. This will produce a cleaner job and prevent the material from cracking or splintering.

The same result can be obtained by clamping a back-up piece to the material and drilling into that.

Select the bit or attachment suitable to the size of the drill and the work to be done. To operate safely and efficiently, the shanks of bits and attachments must turn true.

Make sure that the bit or attachment is properly seated and tightened in the chuck.

Some operations require the use of an impact or hammer drill. For instance, drilling large holes in concrete or rock with

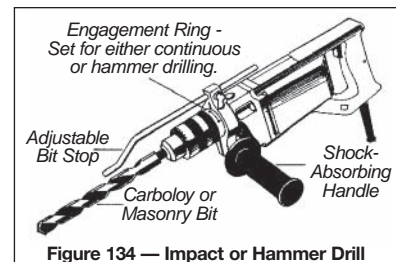


Figure 134 — Impact or Hammer Drill

a carbide bit should be done with an impact drill (Figure 134).

Follow manufacturer's instructions when selecting and using a bit or attachment, especially with drills or work unfamiliar to you.

Working with Small Pieces

Drilling into small pieces of material may look harmless, but if the pieces are not clamped down and supported, they can spin with the bit before the hole is completed.

If a small piece starts to twist or spin with the drill, the operator can be injured. Small work pieces should be properly secured and supported. Never try to drill with one hand and hold a small piece of material with the other.

Drilling from Ladders

Standing on a ladder to drill holes in walls and ceilings (Figure 135) can be hazardous. The top and bottom of the ladder must be secured to prevent the ladder from slipping or sliding when the operator puts pressure on the drill.

When drilling from a ladder, never reach out to either side. Overreaching can cause the ladder to slide or tip.

Never stand on the top step or paint shelf of a stepladder. Stand at least two steps down from the top. When working from an extension ladder, stand no higher than the fourth rung from the top.

When drilling from a ladder, never support yourself by holding onto a pipe or any other grounded object. Electric current can travel from the hand holding the drill through your heart to the hand holding the pipe.

A minor shock can make you lose your balance. A major shock can badly burn or even kill you.

Operation

Always plug in the drill with the switch **OFF**.

Before starting to drill, turn on the tool for a moment to make sure that the shank of the bit or attachment is centred and running true.

Punch a layout hole or drill a pilot hole in the material so that the bit won't slip or slide when you start drilling. A pilot hole is particularly important for drilling into hard material such as concrete or metal.

With the drill **OFF**, put the point of the bit in the pilot hole or punched layout hole.

Hold the drill firmly in one hand or, if necessary, in both hands at the correct drilling angle (Figure 136).

Turn on the switch and feed the drill into the material with the pressure and control required by the size of the drill and the type of material.

Don't try to enlarge a hole by reaming it out with the sides of the bit. Switch to a larger bit.

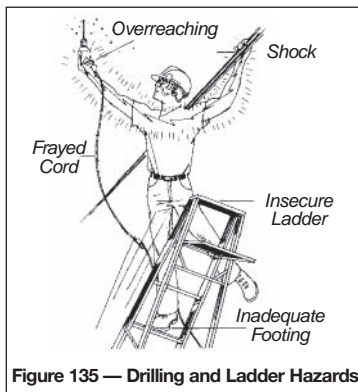
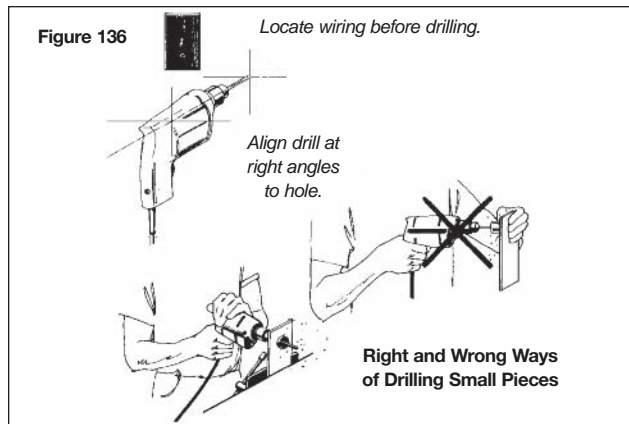


Figure 135 — Drilling and Ladder Hazards



While drilling deep holes, especially with a twist bit, withdraw the drill several times with the motor running to clear the cuttings.

Never support material on your knee while drilling. Material should be firmly supported on a bench or other work surface for drilling.

Unplug the drill and remove the bit as soon as you have finished that phase of your work.

When drilling into floors, ceilings, and walls, beware of plumbing and especially of wiring.

Large rotary and hammer drills can generate extreme torque and must be handled with caution.

Remember that the longer you work, the heavier the drill feels, particularly when working overhead. Take a breather now and then to relax your arms and shoulders.

Drilling Timbers

When drilling timbers with a self-feeding auger bit (Figure 137), do not underestimate the physical pressure required to maintain control of the tool. Such work calls for a heavy-duty, low-rpm drill, 1/2 or 3/4 inch in size.

Never attempt to drill heavy timbers by yourself, especially when working on a scaffold or other work platform. If the self-feeding auger bit digs into a hidden knot or other obstruction, the sudden torque can twist or wrench your arm and throw you off balance.

Other Materials

The main hazard in drilling materials other than wood is leaning too heavily on the tool. This can not only overload and burn out the motor but also cause injury if you are thrown off balance by the drill suddenly twisting or stopping.

Always use a drill powerful enough for the job and a bit or attachment suited to the size of the drill and the nature of the work. As at other times, punching a layout hole or drilling a pilot hole can make the job safer and more efficient.

A drill press stand (Figure 138) is ideal for drilling holes in metal accurately and safely. Small pieces can be clamped

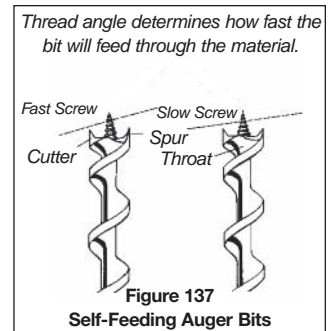


Figure 137
Self-Feeding Auger Bits

in a vise and bolted to the table. This prevents the workpiece from spinning when the drill penetrates the metal.

A drill press can also be used for cutting large holes in wood with a hole saw or spade bit. The stability of the press and the operator's control over cutting speed eliminate sudden torque.

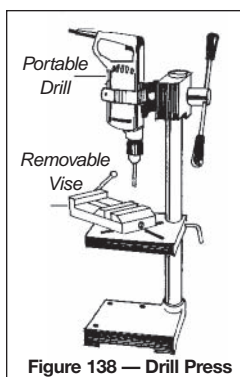


Figure 138 — Drill Press

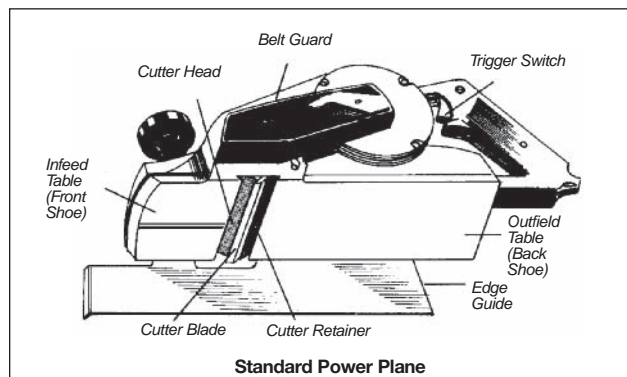
Planes

Available in various types and sizes, electric planes are generally operated in similar ways. Adjustments between models may differ, however, depending on specific features.

Planes may be equipped with

- outfeed tables (back shoes) that are either fixed or movable
- infeed tables (front shoes) that move straight up and down or move up and down on an angle to keep the gap between cutter head and table as small as possible
- cutter heads with two or more straight blades (also called knives or cutter blades)
- cutter heads with two curved blades.

Never operate an electric plane while wearing a scarf, open jacket, or other loose clothing. Always wear eye protection and practice good housekeeping.



Standard Power Plane

Standard Plane

- Hold with both hands to avoid contact with cutter blades.
- Always keep both hands on the plane until motor stops.
- Use the edge guide to direct the plane along the desired cut. Never try to guide the plane with your fingers. If the plane runs into an obstruction or starts to vibrate, your fingers can slide into the unprotected cutter head.

Block Plane (Electric)

Designed for use on small surfaces, the block plane is necessarily operated with only one hand. Though convenient and useful, it is more dangerous than the larger, standard plane.

Operators tend to support the work with one hand while operating the block plane with the other. Any unexpected twist or movement can force the plane or the material to

kick back and injure the operator. Keep your free hand well out of the way, in case the plane slips accidentally.

Maintaining Blades

- Avoid striking staples, nails, sand, or other foreign objects. The first step in operation is to make sure the work is free of obstructions.
- Keep blades in good condition and sharp. A sharp blade is safer to use than a dull blade that has to be held down and forced. A dull blade tends to float over the work and can bounce off, injuring the operator.
- Restore blades to original sharpness on a fine grit oilstone. Unless nicked or cracked, blades can be resharpened several times.

Changing Blades

Raising or replacing cutter blades takes time and patience. Blades must be the same weight and seated at the same height to prevent the cutter head from vibrating. Any deviation can cause the head to run off balance. Blades can fly out, injuring the operator or fellow workers.

Replacing cutter blades involves two steps: removing and installing.

Removing Blades

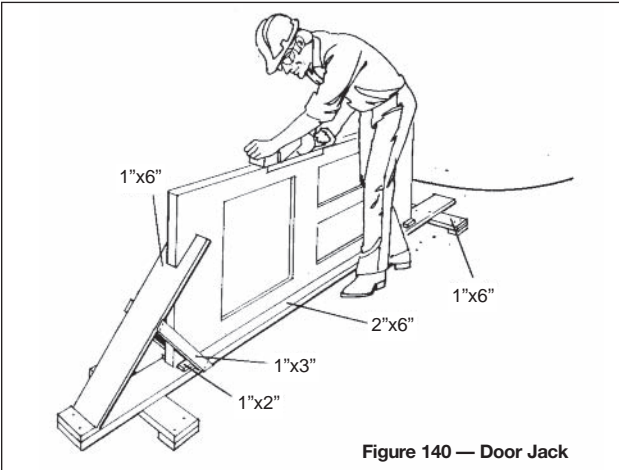
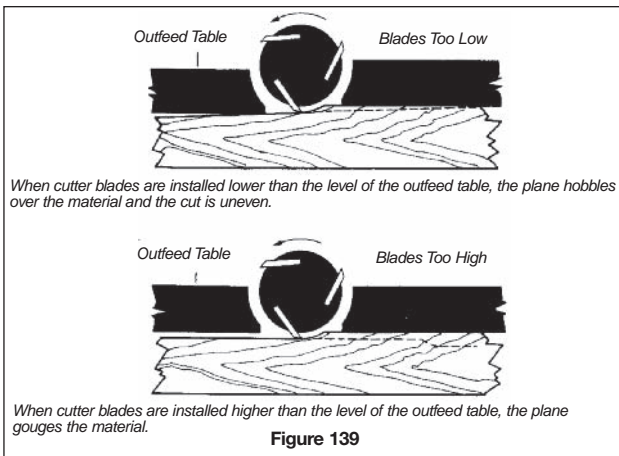
- 1) Disconnect the plane from the power source.
- 2) Turn the plane upside down and secure it in a fixed position.
- 3) Hold the cylinder head stationary by tapping a softwood wedge between the cutter head and the bearing (some tools are equipped with a locking device for this).
- 4) Loosen all the screws and lift out one blade and throat piece.
- 5) Turn the cutter head and repeat this procedure with other blades.
- 6) If necessary, clean parts thoroughly with recommended solvent.

Installing Blades

- 1) Replace one throat piece and blade.
- 2) Tighten the two end screws lightly.
- 3) Take a hardwood straight edge and use the outfeed table (back shoe) as a gauge. Raise or lower the blade until both ends are level with the outfeed table at the blade's highest point of revolution.
- 4) Tighten up the remaining screws.
- 5) Set the rest of the blades in the same way.
- 6) Turn the cylinder head and make sure that all blades are the same height.
- 7) Tighten up all the screws.
- 8) Double-check the height of all blades. Tightening can sometimes shift the set.
- 9) Double-check all the screws.
- 10) Turn the tool right side up and plug it in.
- 11) Hold the tool in both hands with the cutter blades facing away from you and switch it on.

Operation

- Always disconnect the plane from the power source before adjusting or changing blades or the cutter head.
- Make sure that blades at their highest point of revolution are exactly flush with the outfeed table for safe, efficient operation (Figure 139).



- Support work securely for safety and accuracy.
- When planing doors and large pieces of plywood, use a jack (Figure 140) to secure material and keep edges clear of dirt and grit.
- When using an electric block plane, clamp or fasten the workpiece whenever possible. Keep your free hand well away from plane and material.
- When using the standard power plane, adjust the edge guide to provide desired guidance.
- Adjust depth of cut to suit the type and width of wood to be planed.
- To start a cut, rest the infeed table (front shoe) firmly on the material with cutter head slightly behind the edge of the material. After finishing a cut, hold both hands on the plane until motor stops.

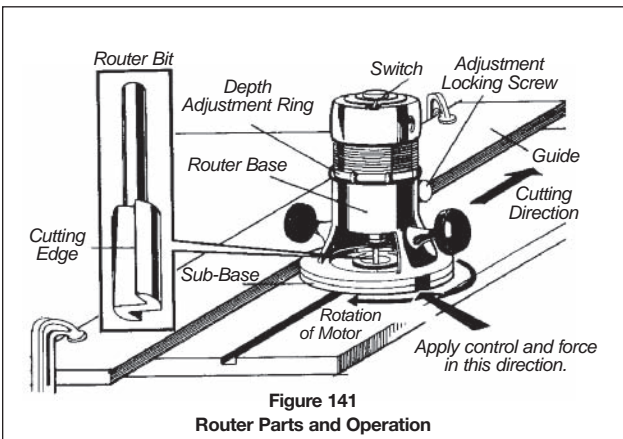
Routers

With special guides and bits, the portable electric router can be used to cut dadoes, grooves, mortises, dovetail joints, moldings, and internal or external curves. Carpenters find routers especially useful for mortising stair stringers and recessing hinges and lockplates on doors.

The router motor operates at very high speed (up to 25,000 rpm) and turns clockwise. Components are shown in Figure 141.

WARNING The speed and power of the router require that it be operated with both hands.

When starting a router with a trigger switch in the handle,



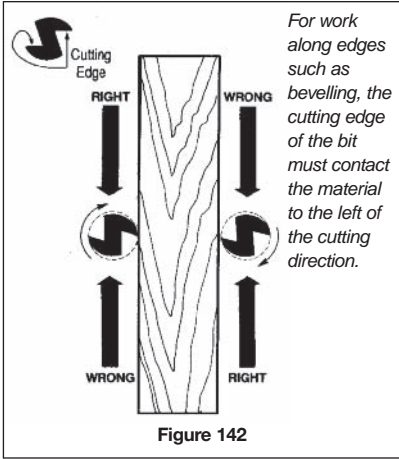
keep both hands on the tool to absorb the counterclockwise starting torque.

When starting a router with a toggle switch on top of the motor, hold the router firmly with one hand and switch on power with the other, then put both hands on the tool for control and accuracy.

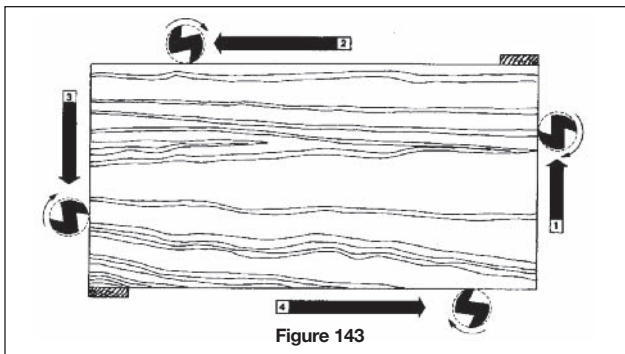
Always wear eye protection. You may also need hearing protection.

Operation

- Always support and secure the work in a fixed position by mechanical means such as a vise or clamps. Never try to hold the work down with your hand or knee. Never rely on a second person to hold the material. Human grip is no match for the torque and kickback that a router can generate.
- Make sure that the bit is securely mounted in the chuck and the base is tight.
- Set the base on the work, template, or guide and make sure that the bit can rotate freely before switching on the motor.



- For work along edges such as bevels and moldings, make sure that the cutting edge of the router bit contacts the material to the **left** of the cutting direction (Figure 142). Otherwise the router will kick back or fly away from you.
- When routing outside edges, guide the router around the work counterclockwise (Figure 143). Splinters left at corners by routing **across** the grain will be removed by the next pass **with** the grain.
- Feed the router bit into the material at a firm but controllable speed. There is no rule on how fast to cut. When working with softwood, the router can sometimes be moved as fast as it can go. Cutting may be very slow, however, with hardwood, knotty or twisted wood, and larger bits.



- Listen to the motor. When the router is fed into the material too slowly, the motor makes a high-pitched whine. Push too hard and the motor makes a low growling noise. Forcing the tool can cause burnout or kickback. Cutting through knots may cause slowdown or kickback.
- When the type of wood or size of bit requires going slow, make two or more passes to prevent the router from burning out or kicking back.
- If you're not sure about depth of cut or how many passes to make, test the router on a piece of scrap similar to the work.
- When the cut is complete, switch off power and keep both hands on the router until the motor stops. In lifting the tool from the work, avoid contact with the bit.

38 POWER TOOLS — SAWS

The saws covered in this chapter are

- circular – quick-cut
- sabre – table
- chain – radial arm
- chop

Basic Saw Safety

- Wear protective clothing and equipment (see the chapters on personal protective equipment in this manual). Eye protection is essential.
- Where saws are used in confined spaces or for prolonged periods, wear hearing protection.
- Where ventilation is inadequate, wear a dust mask for protection against dust. Over time, exposure to dust from particle board and other materials may cause respiratory problems.
- With electric saws operated outdoors or in wet locations, you must use a ground fault circuit interrupter.
- Never wear loose clothing, neck chains, scarves, or anything else that can get caught in the saw.
- Leave safety devices in place and intact on the saw. Never remove, modify, or defeat guards. Keep your free hand away from blade (Figure 144).

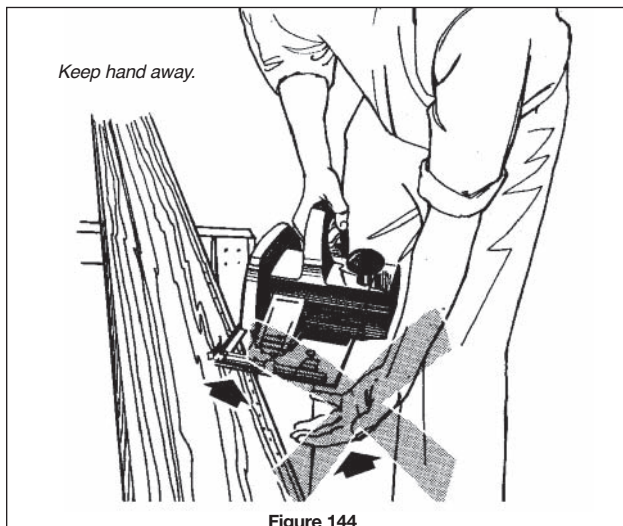
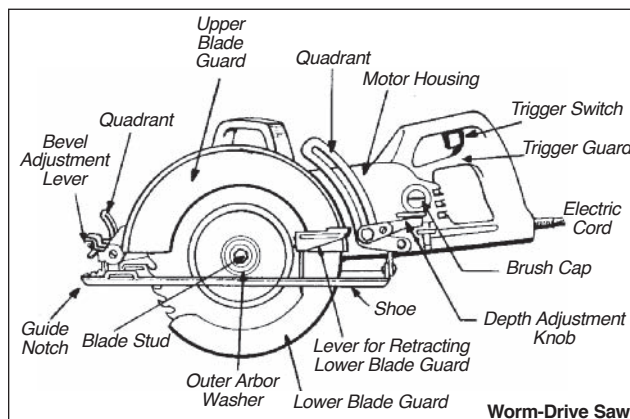
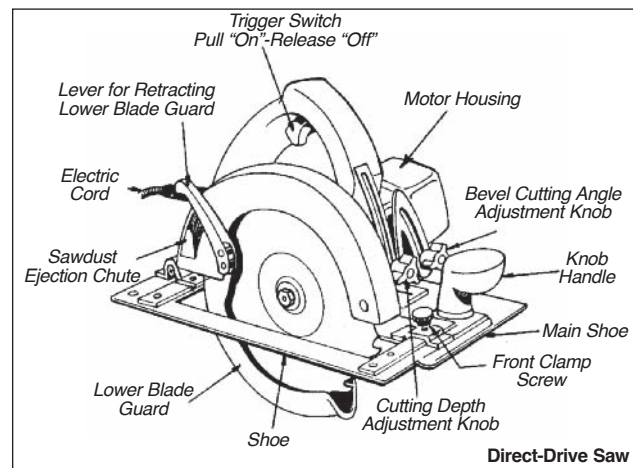


Figure 144

- Always change and adjust blades with the power OFF. Disconnect electric saws from the power source before making changes or adjustments.



Worm-Drive Saw



Direct-Drive Saw

Circular Handsaws

The two models most often used on construction sites are illustrated. The main difference between the two lies in the drive action. The worm-drive saw has gears arranged so that the blade runs parallel to the motor shaft. The direct-drive saw has the blade at a right angle to the motor shaft.

The worm-drive saw periodically requires special gear oil to keep the inner gears lubricated. This requirement is usually eliminated in the direct-drive saw, which has sealed bearings and gears.

Both saws must be inspected regularly for defects, and operated and maintained in accordance with manufacturers' recommendations.

Check for

- | | |
|----------------------------|-----------------------------|
| – damaged cord | – loose blade |
| – faulty guards | – defective trigger |
| – chipped or missing teeth | – cracked or damaged casing |

Safety Features

Sawdust Ejection Chute

This feature prevents sawdust from collecting in front of the saw and obscuring the cutting line. The operator can continue cutting without having to stop the saw and clear away sawdust.

Clutch

Some worm-drive saws are equipped with a clutch to prevent kickback. Kickback occurs when a saw meets resistance and violently backs out of the work. The clutch action allows the blade shaft to continue turning when the blade meets resistance. The blade stud and friction washer can be adjusted to provide kickback protection for cutting different materials. Check friction washers for wear.

Brake

An electric brake on some circular saws stops the blade from coasting once the switch is released. This greatly reduces the danger of accidental contact.

Trigger Safety

On some light-duty saws a latch prevents the operator from accidentally starting the motor. The trigger on the

inside of the handle cannot be pressed without first pressing a latch on the outside of the handle. On heavy-duty saws a bar under the trigger switch helps to prevent accidental starting.

Blades

Blades should be sharpened or changed frequently to prolong saw life, increase production, and reduce operator fatigue. The teeth on a dull or abused blade will turn blue from overheating. Cutting will create a burning smell. Such blades should be discarded or reconditioned.

Before changing or adjusting blades, disconnect the saw from the power source.

Take care to choose the right blade for the job. Blades are available in a variety of styles and tooth sizes. Combination blades (rip and crosscut) are the most widely used.

Ensure that arbor diameter and blade diameter are right for the saw.

Because all lumber is not new, make sure it is clean and free of nails, concrete, and other foreign objects. This precaution not only prolongs blade life but may also prevent serious injury.

Take special care to ensure that blades are installed in the proper rotational direction (Figure 145). Remember that electrical circular handsaws cut with an upward motion. The teeth visible between the upper and lower guard should be pointing toward the front of the saw. Most models have a directional arrow on both blade and guard to serve as a guide.

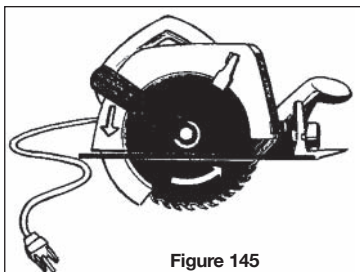


Figure 145

Blade Guards

Never operate an electric saw with the lower guard tied or wedged open. The saw may kick back and cut you, or another worker may pick up the saw and – not knowing that the guard is pinned back – get hurt.

Accidents have also occurred when the operator forgot that the blade was exposed and put the saw on the floor. The blade, still in motion, forced the saw to move, cutting anything in its path.

Make sure that the lower guard returns to its proper position after a cut. Never operate a saw with a defective guard-retracting lever.

On most saws the lower guard is spring-loaded and correct tension in the spring will automatically close the guard. However, a spring weakened by use and wear can allow the guard to remain open after cutting. This creates a potential for injury if the operator inadvertently rests a still turning blade against his leg after finishing a cut. Always maintain complete control of the saw until the blade stops turning. The guard may also be slow to return after 45° cuts.

Choosing the Proper Blade

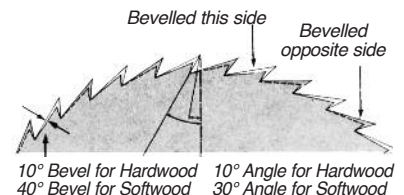
For safety, saw operators must understand the different designs and uses of blades (Figure 146). Blades unsuited for the job can be as hazardous as dull blades. For instance, a saw fitted with the wrong blade for the job can run hot so quickly that blade tension changes and creates a wobbly motion. The saw may kick back dangerously before the operator can switch it off.

Resharpened blades can be substantially reduced in diameter – for instance, from nine to eight inches. Make sure that the blade diameter and arbor diameter are right for the saw.

Carbide-Tipped Blades – Take special care not to strike metal when using a carbide-tipped blade. The carbide tips can come loose and fly off, ruining the blade and injuring the operator. Inspect the blade regularly for cracked or missing tips.

Crosscut Blade —

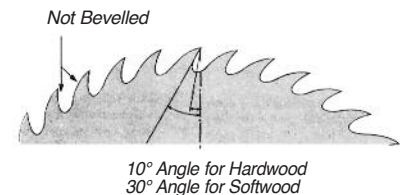
The bevelled sharp-pointed teeth are designed to cut the crossgrain in wood. Size and bevel of the teeth are important factors in cutting different woods.



Softwood requires bigger teeth to carry off the sawdust. Hardwood requires fine teeth with many cutting edges. Note the different angles and edges needed for cutting hardwood and softwood.

Ripsaw Blade — The

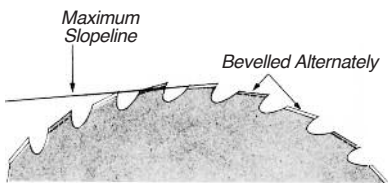
flat sharp teeth are designed to cut the long grain in wood. They are neither bevelled nor needle-pointed. Needle-pointed teeth would get clogged and the



blade would become overheated. Never use a ripsaw blade for crosscutting or for cutting plywood. The material can jam and overheat the blade or splinter in long slivers that may seriously injure the operator.

Combination Blade

This blade combines features of the crosscut and ripsaw blades. It can be used for crosscutting and ripping, or for



cutting plywood. Carpenters on construction sites prefer the combination blade for rough woodworking such as stud walls and formwork because they don't have to change blades. The teeth are alternately bevelled and have a straight front. The heel of each tooth is not lower than the heel of the tooth on either side of it.

Standard Combination or Mitre Blade

This is mainly used by trim carpenters. It includes teeth for crosscutting, raker teeth for ripping, and deep gullets for carrying off sawdust. The blade can be used for cutting both hardwood and softwood and for mitring.

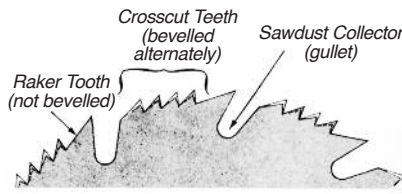


Figure 146

Changing, Adjusting, and Setting Blades

When changing blades, take the following precautions.

1. Disconnect the saw from the power source.
2. Place the saw blade on a piece of scrap lumber and press down until the teeth dig into the wood (Figure 147). This prevents the blade from turning when the locking nut is loosened or tightened. Some machines are provided with a mechanical locking device.
3. Make sure that keys and adjusting wrenches are removed before operating the saw.

Proper adjustment of cutting depth keeps blade friction to a minimum, removes sawdust from the cut, and results in cool cutting.

The blade should project the depth of one full tooth below the material to be cut (Figure 148). When using carbide-tipped blades or mitre blades let only half a tooth project below the material. If the blade is to run freely in the kerf (saw cut), teeth must be set properly, that is, bent alternately (Figure 149). The setting of teeth differs from one type of blade to another. Finer-toothed blades require less set than rougher-toothed blades. Generally, teeth should be alternately bent 1/2 times the thickness of the blade.

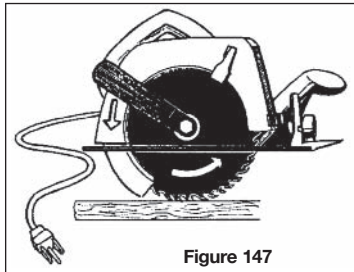


Figure 147

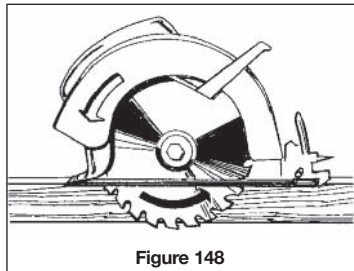


Figure 148

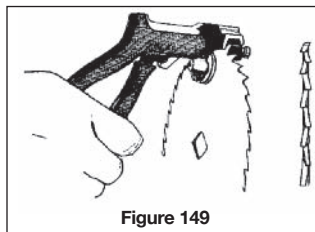


Figure 149

Sharp blades with properly set teeth will reduce the chance of wood binding. They will also prevent the saw from overheating and kicking back.

Cutting

Place the material to be cut on a rigid support such as a bench or two or more sawhorses. Make sure that the blade will clear the supporting surface and the power cord. The wide part of the saw shoe should rest on the supported side of the cut if possible.

Plywood is one of the most difficult materials to cut with any type of saw. The overall size of the sheet and the internal stresses released by cutting are the main causes of difficulty. Large sheets should be supported in at least three places, with one support next to the cut.

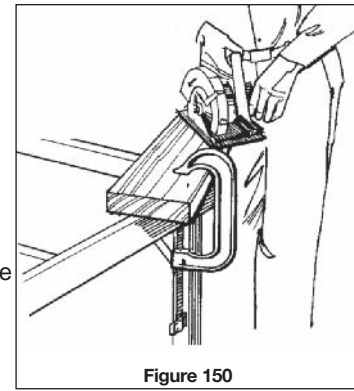


Figure 150

Short pieces of material should not be held by hand. Use some form of clamping to hold the material down when cutting it (Figure 150).

NEVER use your foot or leg to support the material being cut. Too many operators have been seriously injured by this careless act.

The material to be cut should be placed with its good side down, if possible. Because the blade cuts upward into the material, any splintering will be on the side which is uppermost.

Use just enough force to let the blade cut without labouring. Hardness and toughness can vary in the same piece of material, and a knotty or wet section can put a heavier load on the saw. When this happens, reduce pressure to keep the speed of the blade constant. Forcing the saw beyond its capacity will result in rough and inaccurate cuts. It will also overheat the motor and the saw blade.

Take the saw to the material. Never place the saw in a fixed, upside-down position and feed material into it. Use a table saw instead.

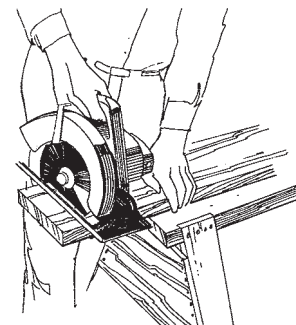
If the cut gets off line, don't force the saw back onto line. Withdraw the blade and either start over on the same line or begin on a new line.

If cutting right-handed, keep the cord on that side of your body. Stand to one side of the cutting line. **Never reach under the material being cut.**

Always keep your free hand on the long side of the lumber and clear of the saw. Maintain a firm, well-balanced stance, particularly when working on uneven footing.

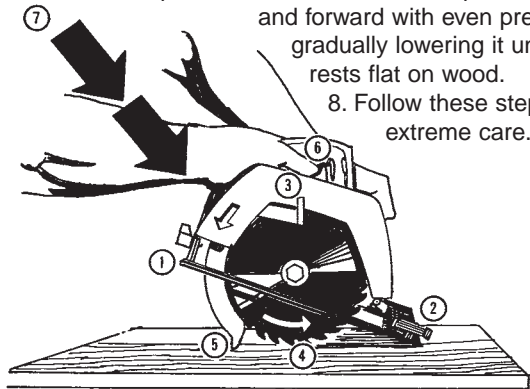
Plywood, wet lumber, and lumber with a twisted grain tend to tighten around a blade and may cause kickback. Kickback occurs when an electric saw stalls suddenly and jerks back toward the operator. The momentarily exposed blade may cause severe injury.

Use extreme caution and don't relax your grip on the saw.



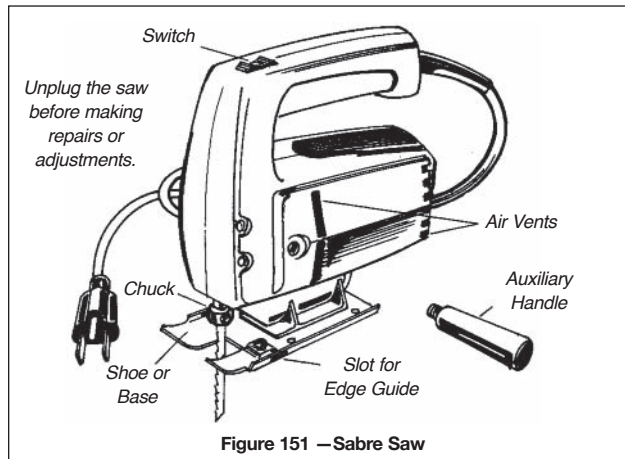
Pocket Cutting

1. Tilt saw forward.
2. Rest front of shoe on wood.
3. Retract lower guard.
4. Lower saw until front teeth almost touch wood.
5. Release guard to rest on wood.
6. Switch on the saw.
7. Keep the saw tilted forward and push it down and forward with even pressure, gradually lowering it until shoe rests flat on wood.
8. Follow these steps with extreme care.



Sabre Saws

The sabre saw, or portable jigsaw (Figure 151), is designed for cutting external or internal contours. The saw should not be used for continuous or heavy cutting that can be done more safely and efficiently with a circular saw.



The stroke of the sabre saw is about 1/2 inch for the light-duty model and about 3/4 inch for the heavy duty model. The one-speed saw operates at approximately 2,500 strokes per minute. The variable-speed saw can operate from one to 2,500 strokes per minute.

The reciprocating saw (Figure 152) is a heavier type of sabre saw with a larger and more rugged blade. The tool is often used by drywall and acoustical workers to cut holes in ceilings and walls. Equipped with a small swivel base, the saw can be used in corners or free-hand in hard-to-reach places. The reciprocating saw must be held with both hands to absorb vibration and to avoid accidental contact.

Eye protection is a must. You may also need respiratory protection.

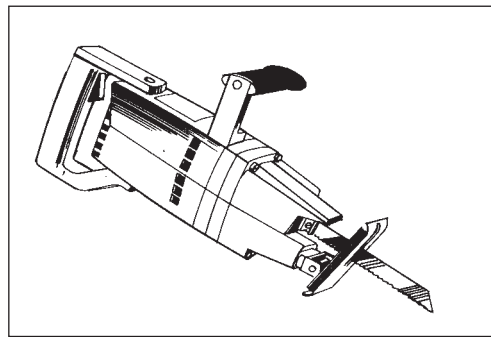
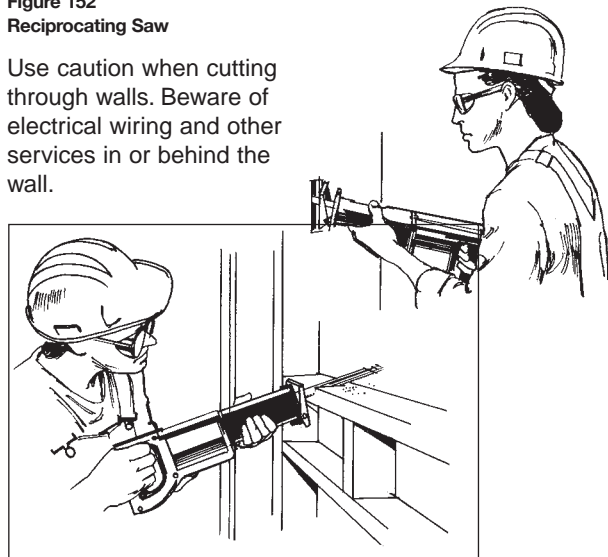


Figure 152
Reciprocating Saw

Use caution when cutting through walls. Beware of electrical wiring and other services in or behind the wall.



Choosing the Proper Blade

Various blades, ranging from 7 to 32 teeth per inch, are available for cutting different materials. For the rough cutting of stock such as softwood and composition board, a blade with 7 teeth per inch will cut the fastest. For all-round work with most types of wood, a blade with 10 teeth per inch is satisfactory.

Cutting

The sabre saw cuts on the upstroke. Splintering will therefore occur on the top side of the material being cut. Consequently, the good side should be facing down. The degree of splintering depends on the type of blade, the vibration of the material, and the feed of the saw.

To avoid vibration, the material should be clamped or otherwise secured and supported as close to the cutting line as possible. If the material vibrates excessively or shifts during cutting, the saw can run out of control, damaging the blade and injuring the operator.

- Before starting a cut make sure that the saw will not contact clamps, the vise, workbench, or other support.
- Never reach under the material being cut.
- Never lay down the saw until the motor has stopped.
- Do not try to cut curves so tight that the blade will twist and break.
- Always hold the base or shoe of the saw in firm contact with the material being cut.

WARNING When sawing into floors, ceiling, or walls, always check for plumbing and wiring.

External Cut (Figure 153)

To start an external cut (from the outside in), place the front of the shoe on the material. Make sure that the blade is not in contact with the material or the saw will stall when the motor starts.

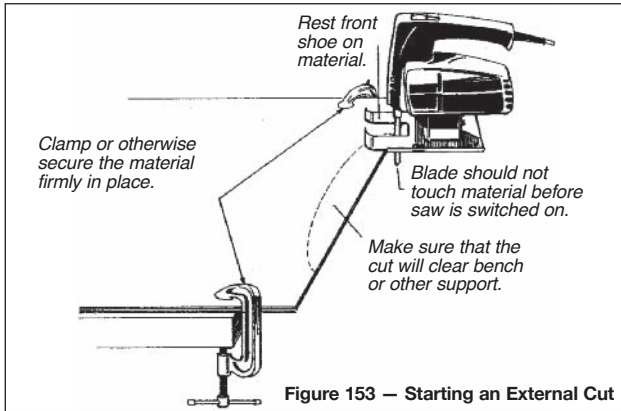
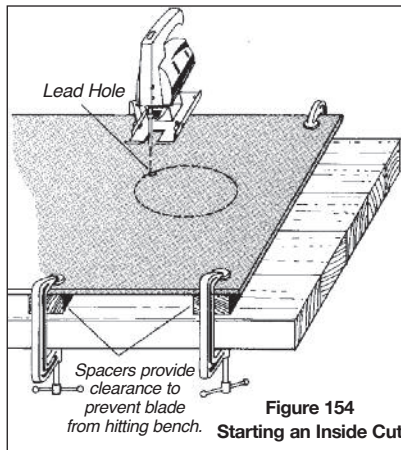


Figure 153 – Starting an External Cut

Hold the saw firmly and switch it on. Feed the blade slowly into the material and maintain an even pressure. When the cut is complete, do not lay down the saw until the motor has stopped.

Inside Cuts (Figure 154)

To start an inside cut (pocket cut), first drill a lead hole slightly larger than the saw blade. With the saw switched off, insert the blade into the hole until the shoe rests firmly on the material. Do not let the blade touch the material until the saw has been switched on.



It is possible to start an inside cut without drilling a lead hole first — but only when it's absolutely necessary. To do this, tip the tool forward so that the front edge of the shoe rests on the workpiece and the teeth of the blade face the material. Keep the blade out of contact with the material.

Switch on the saw and slowly feed the blade into the material while lowering the back edge of the shoe. When the shoe rests flat on the material and the blade is completely through, proceed with the cut. Any deviation from this procedure can cause the blade to break and injure the operator or workers nearby.

Never try to insert a blade into, or withdraw a blade from, a cut or a lead hole while the motor is running.

Never reach under the material being cut.

Chainsaws

Each year in Ontario, construction workers are injured while using chainsaws. Generally the injuries result from two types of accidents:

- 1) the operator makes accidental contact with the revolving chain
- 2) the operator is struck by the object being cut, usually a tree or heavy limb.

Many of these injuries are serious.

While the chainsaw is relatively easy to operate, it can be lethal. As with all high-speed cutting tools, it demands the full attention of even the trained and experienced operator.

Requirements

Chainsaws can be powered by electric motors (Figure 155) or gasoline engines (Figure 156).

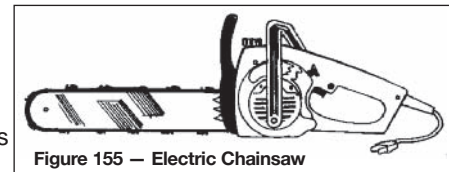


Figure 155 – Electric Chainsaw

Both saws are designed to provide fast cutting action with a minimum of binding in the cut, even though wood may be sap-filled or wet. Both afford about the same performance in terms of horsepower and they are equipped with similar controls and safety devices.

Regulations require that chainsaws used in construction must be equipped with a chain brake. Make sure that the saw is equipped with a chain brake mechanism, and not simply a hand guard, which is similar in appearance.

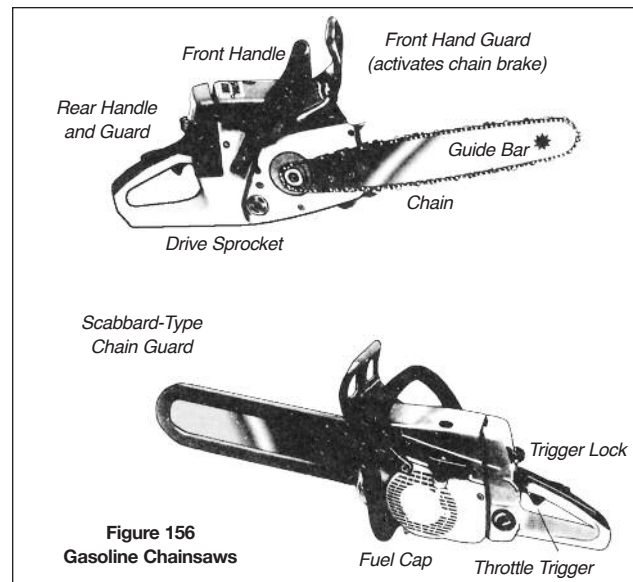


Figure 156 Gasoline Chainsaws

Regulations require that chainsaws used in construction must be equipped with “anti-kickback” chains. Called safety chains (Figure 157) by the manufacturers, these chains incorporate design features intended to minimize kickback while maintaining cutting performance.

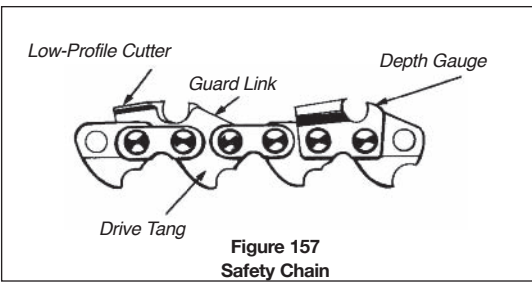


Figure 157
Safety Chain

Protective Clothing and Equipment

- Eye protection in the form of plastic goggles is recommended. A faceshield attached to the hard hat will not provide the total eye protection of close-fitting goggles.
- Leather gloves offer a good grip on the saw, protect the hands, and absorb some vibration. Gloves with ballistic nylon reinforcement on the back of the hand are recommended.
- Since most chainsaws develop a high decibel rating (between 95 and 115 dBA depending on age and condition), adequate hearing protection must be worn, especially during prolonged exposure.
- Trousers or chaps with sewn-in ballistic nylon pads provide excellent protection, particularly for the worker who regularly uses a chainsaw.

Kickback

Kickback describes the violent motion of the saw that can result when a rotating chain is unexpectedly interrupted. The cutting chain's forward movement is halted and energy is transferred to the saw, throwing it back from the cut toward the operator.

The most common and probably most violent kickback occurs when contact is made in the "kickback zone" (Figure 158).

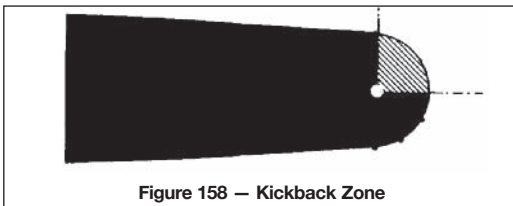


Figure 158 – Kickback Zone

Contact in this zone makes the chain bunch up and try to climb out of the track. This most often happens when the saw tip makes contact with something beyond the cutting area such as a tree branch, log, or the ground.

To minimize the risk of kickback

- use a low-profile safety chain
- run the saw at high rpm when cutting
- sharpen the chain to correct specifications
- set depth gauges to manufacturers' settings
- maintain correct chain tension
- hold the saw securely with both hands
- don't operate the saw when you are tired
- know where the bar tip is at all times
- don't allow the cut to close on the saw
- make sure the chain brake is functioning.

Starting

When starting, hold the saw firmly on the ground or other level support with the chain pointing away from your body and nearby obstructions. Use a quick, sharp motion on the starter pull (Figure 159). Never "drop start" the saw. This leaves only one hand to control a running saw and has resulted in leg cuts. Use the proper grip (Figure 160).

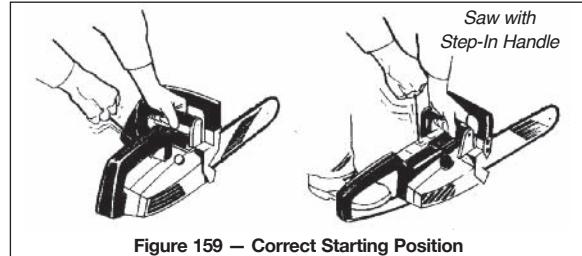


Figure 159 – Correct Starting Position

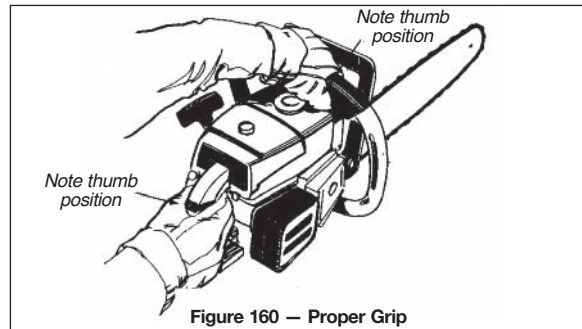


Figure 160 – Proper Grip

Before moving from place to place, shut off the saw and walk with the guide bar pointed backwards. A trip or a stumble with a running saw can cause serious injury.



Site Hazards

- Take extra care when making pocket cuts (Figure 161). Start the cut with the underside of the chain tip, then work the saw down and back to avoid contact with the kickback zone. Consider an alternative such as a sabre saw.

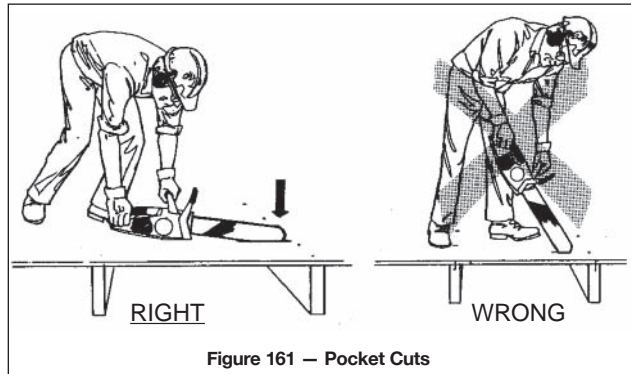


Figure 161 – Pocket Cuts

- Be particularly careful to avoid contact with nails, piping, and other metallic objects. This is especially important when making a pocket cut through framing lumber such as a subfloor or when cutting used lumber such as trench shoring, lagging, or blocking timbers.

- Use chainsaws to cut wood only. They are not designed to cut other materials.
- When using a chainsaw to trim rafter ends, take the following steps to avoid injury:
 - Cut down from the top of the rafter. Don't cut from underneath.
 - Use a harness, lanyard, and lifeline to prevent falls or work from a secure scaffold at eaves level.
 - The extension cord on an electric chainsaw should be secured on the roof above the operator with enough working slack. This will prevent the weight of a long cord from pulling the operator off balance.
 - Keep both hands firmly on the saw.

Maintenance

Well-maintained cutting components are essential for safe operation. A dull or improperly filed chain will increase the risk of kickback.

- Inspect and maintain your saw according to the manufacturer's recommendations regarding chain tension, wear, replacement, etc. Check for excessive chain wear and replace chain when required. Worn chains may break!
- Select the proper size files for sharpening the chain. Two files are necessary:
 - 1) a flat file for adjusting depth gauge
 - 2) a round file of uniform diameter for sharpening cutters and maintaining drive links.

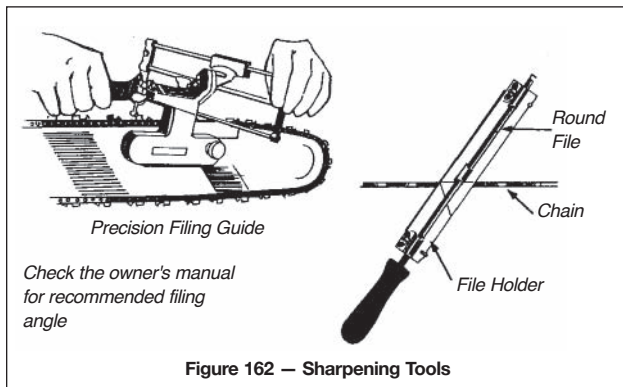


Figure 162 – Sharpening Tools

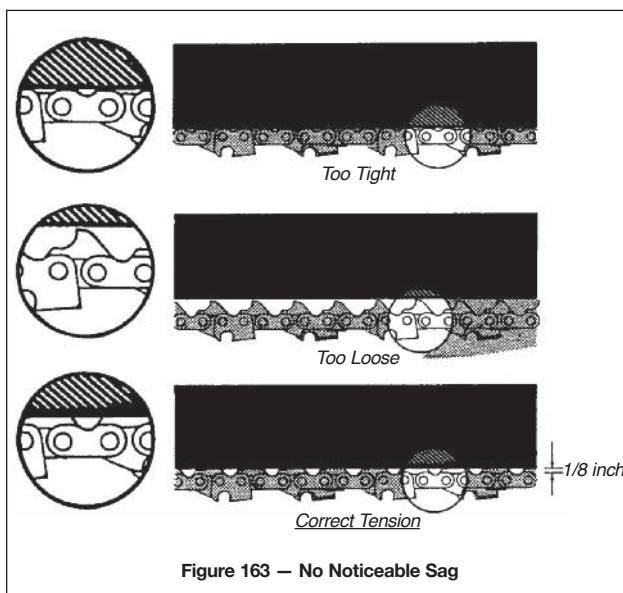


Figure 163 – No Noticeable Sag

- You must choose the correct round file for your chain to avoid damaging the cutters. Consult the owner's manual or the supplier to be sure of file size.
- A round file used in combination with a file holder or, better yet, a precision filing guide will give the best results (Figure 162).

Adjusting Chain Tension

- Follow the manufacturer's instructions on chain tension.
- In general, the chain should move easily around the bar by hand without showing noticeable sag at the bottom (Figure 163).
- Be generous with chain lubricating oil. It is almost impossible to use too much. Most late model saws have automatic oilers. **But operators must still remember to fill the chain-oil reservoir.**

Chop Saws

Increasingly, carpenters and other trades are using chop saws to cut various materials (Figure 164). These portable saws offer quick, efficient, and economical cutting.

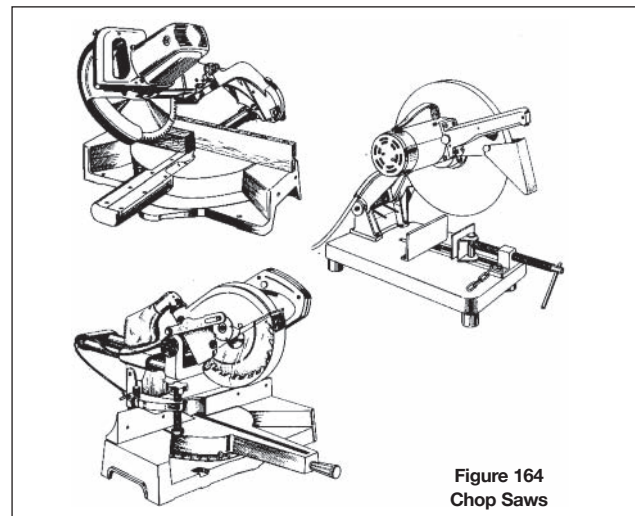


Figure 164 Chop Saws

Unfortunately, like all power equipment, chop saws pose serious hazards for the unwary or untrained operator. Follow **Basic Saw Safety** (at the beginning of this chapter) and **Safety Basics** (at the beginning of the chapter on "Power Tools – Drills, Planes, Routers) as for other power saws.

Most of these saws are equipped with abrasive wheels for quick cutting through metal studs and other material.

- Select the proper abrasive cutting wheel for the material being cut. For metals, use aluminum oxide. For masonry, stone, and concrete, use silica carborundum.
- The rpm of the saw should not exceed the recommended rpm printed on the blade label.
- The centre hole on the blade must fit the mandril and be snugly fastened in place with the proper washer and lock nut.

Warning A loose or off-centre blade can shatter in use.

- Position material to be cut at 90 degrees to the blade. Support the other end to prevent the blade from binding.
- Do not rush cutting. Let the wheel cut without burning or jamming.

- When cutting is complete, let the blade stop before moving material.
- Maintain the saw in good repair with the blade guard in place and working smoothly. Tighten any loose parts and replace any broken or damaged ones.
- Don't try to adjust for length on downward cutting motion. Your hand could slide into the blade while it is spinning.
- With some large chop saws (Figure 165), additional precautions are required because of the tremendous torque the saws can develop.
- Beware of sparks landing on combustible material.

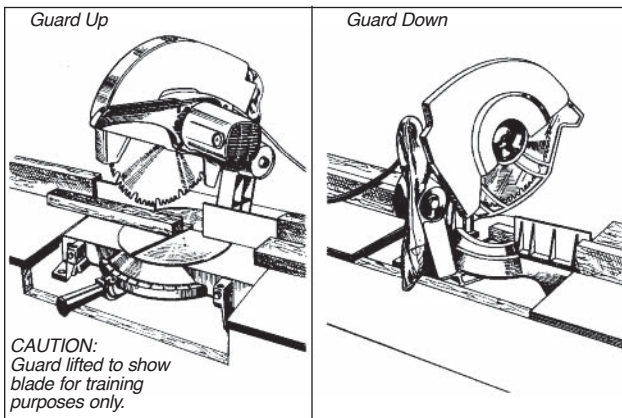


Figure 165 – Some large chop saws may require additional precautions.

Quick-Cut Saws

Hand-held portable circular cut-off saws are commonly known as “quick-cut saws” in construction (Figure 166). They are widely used for cutting concrete, masonry products, sheet metal products (both steel and aluminum), and light steel sections such as angles and channels.

Hazards

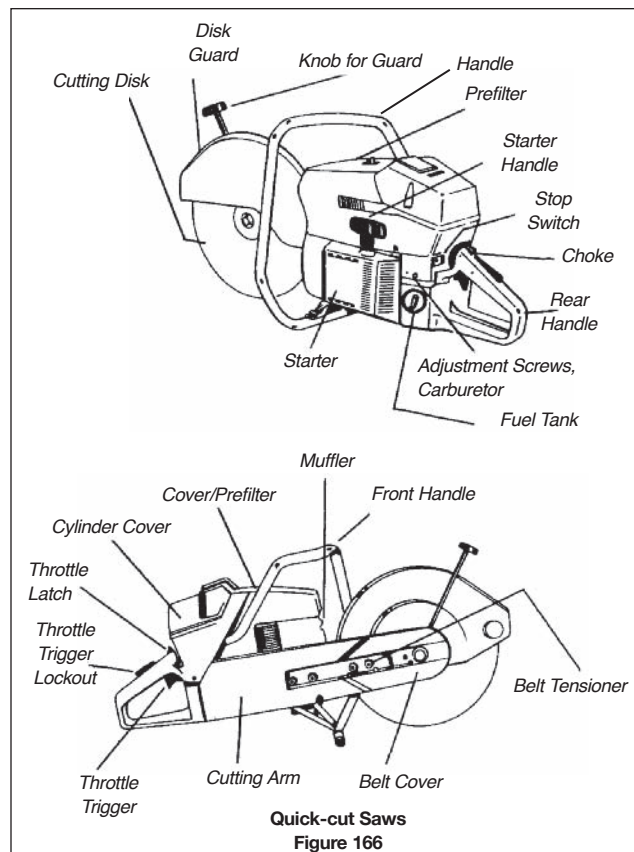
Quick-cut saws are high-powered compared to similar tools. Hazards include high-speed blade rotation, blade exposure during operation, and exhaust from the internal combustion engine (the usual power source).

The saws also create clouds of dust when dry-cutting masonry and showers of hot sparks when cutting metal products, especially steel.

These hazards can result in cuts, kickbacks, exposure to carbon monoxide fumes, exposure to dusts (silica from concrete and masonry products in particular), burns, flying particles hitting the eye, and other injuries from flying material when work is not secured for cutting or when blades fly apart.

These hazards can be controlled by

- operators trained to use quick-cut saws properly and to wear the right protective equipment such as eye, hearing, and respiratory protection as well as face shields and gloves
- saws kept in good working condition, equipped with proper blades or disks, and used with all guards in place
- work secured to keep it from shifting during cutting
- caution around sharp edges left by cuts.



Quick-cut Saws
Figure 166

Training

Operators should be instructed in the care, maintenance, and operation of quick-cut saws. They should read the operating manual, review the major points, and receive both oral and written instruction.

The operating manual should be available on the job, not only for instruction but for ready reference if something goes wrong with the saw or it must be used for work outside the operator's experience.

Time spent on instruction will reduce accidents and injuries as well as prolong the service life of the saw.

As a minimum the operator should be instructed in

- care of the saw
- installing disks and blades
- mixing fuel and fueling the saw
- starting the saw
- supporting and securing work to be cut
- proper cutting stance and grip
- proper cutting techniques for different material
- respiratory protection against dusts
- how to inspect and store abrasive disks.

Care

Quick-cut saws must be serviced and maintained in accordance with the manufacturers' instructions. Replacement parts should be those recommended by the manufacturer.

Cracked, broken, or worn parts should be replaced before the saw is used again. Guards and air-intakes should be cleaned regularly and often. Abrasive disks should be

checked before installation and frequently during use. Correct any excessive blade vibration before trying to make a cut.

In confined areas, make sure that ventilation is adequate. Gasoline-driven saws release carbon monoxide gas — odourless, colourless, and highly toxic.

Starting

Most of the following procedures are for gasoline-powered quick-cut saws — the type most commonly used in construction.

- Use caution when preparing the oil/gasoline mixture and when fuelling the saw. No smoking or ignition sources should be allowed in the area where fuel is mixed or tanks are filled.
- Fill the tank outdoors in a well-ventilated space at least 3 metres from the area where the saw will be used. Spilled fuel should be wiped off the saw.
- Avoid fuelling the saw on or near formwork. Gasoline spills are a fire hazard. Use a funnel to avoid spills.
- Do not overfill the saw or run it without securing the fuel tank cap. Gasoline seeping from the tank can saturate your clothing and be ignited by sparks thrown off from metal cutting. The only cap to use is one supplied by the manufacturer.
- Check the saw for leaks. Sometimes vibration makes gas lines leak.
- Start the saw in an area clear of people and obstacles. Under no circumstances should anyone be standing in front of the saw as it starts or while it's running.
- Put the saw on a smooth hard surface for starting. The guard should be properly set for the type of cut beforehand.
- Assume a solid well-balanced stance. Do not wrap the starter cord around your hand — this can cause injury.
- Set one foot on the rear handle, put one hand on the top handle to lift the blade off the surface, and use the other hand to pull the starter cord (Figure 167).

Warning: Always shut off saw before fuelling.
Keep fuel container well clear of work area.

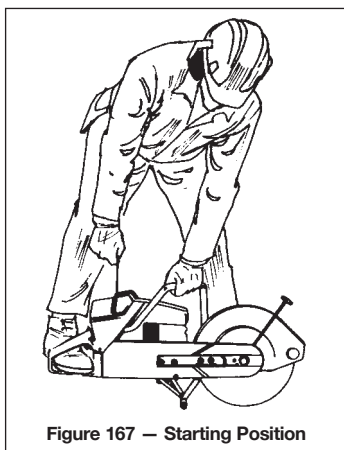


Figure 167 — Starting Position

- Once the saw is running, release the throttle and make sure the engine drops to idle without the disk or blade moving.

- Run the engine at full throttle and let the disk or blade run freely to make sure it turns on the arbor without wobbling or vibrating.

Support

One of the major hazards with quick-cut saws is failure to support and secure the work to be cut.

The saw is powerful enough to throw material around unless it is securely held and supported. Standing on material to hold it down is **not** recommended.

For repeated cuts of masonry or metal pieces, a jig is ideal for efficiency and safety. The jig should be designed and built to hold material in place after measurement without further manual contact (Figure 168).

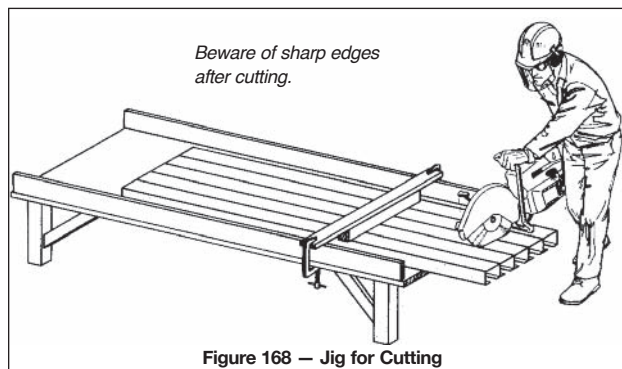


Figure 168 — Jig for Cutting

Stance and Grip

The quick-cut saw is a heavy, powerful tool that must be held by hand. Operators need a secure stance with legs apart for balance and support. The saw should be held at a comfortable, balanced location in front of the operator.

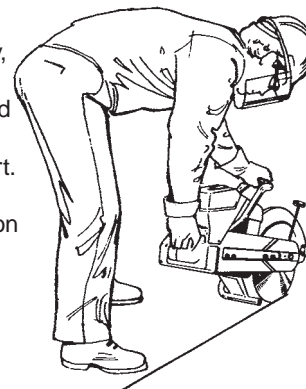


Figure 169 Cutting Stance and Grip

Grip the saw firmly with one hand on each handle. Hold your forward arm straight to keep the saw from kicking back or climbing out of the cut (Figure 169).

Cutting

Although skill in handling the quick-cut saw can only be learned through practice, some safety considerations and operating techniques must always be kept in mind, even by the most experienced operators.

Work should be supported so that the disk or blade will not bind in the cut. Support heavy materials on both sides of the cut so the cut piece will not drop or roll onto the operator's foot. Light materials can generally be allowed to fall. In all cases the cut should be as close as possible to the supporting surface (Figure 170).

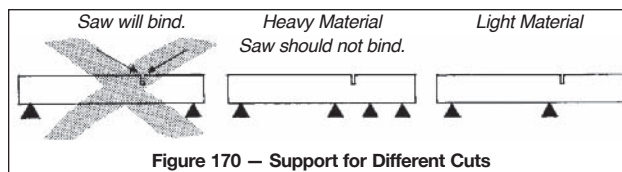


Figure 170 — Support for Different Cuts

Kickback and Pull-In

Kickback can happen extremely fast and with tremendous power. If the segment of the disk or blade shown in Figure 171 contacts the work, the disk or blade starts to climb out of the cut and can throw the saw up and back toward the operator with great force.

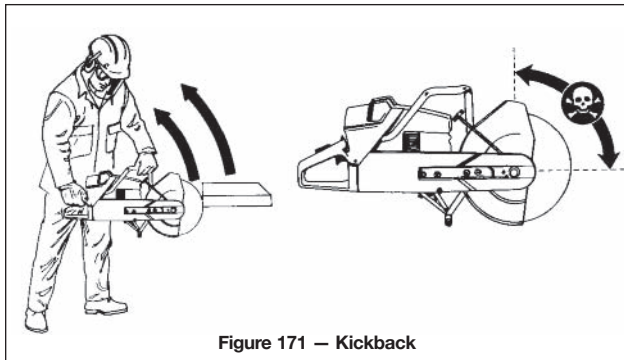


Figure 171 – Kickback

For cutting, keep the throttle wide open. Ease the blade down onto the cut line. Don't drop or jam the blade down hard. Move the saw slowly back and forth in the cut.

Hold the saw so that disk or blade is at right angles to the work and use only the cutting edge of the disk or blade (Figure 172). Never use the side of a disk for cutting. A worn disk will almost certainly shatter and may cause severe injury.

Beware of blade run-on. The blade may continue to rotate after the cut and run away with a saw set down too soon.

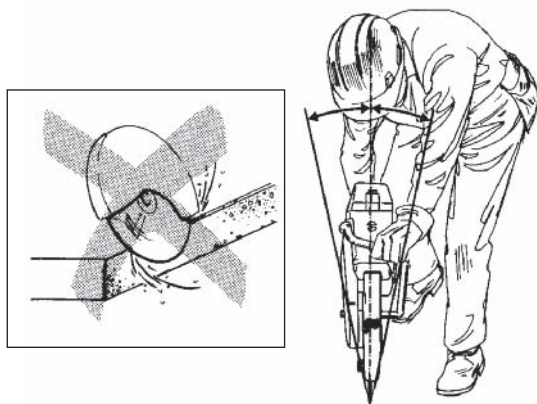


Figure 172 – Saw at Right Angles to Material

Don't force the saw to one side of the cut. This will bend the disk or blade and cause it to bind, possibly to break.

Water cooling is recommended for cutting masonry materials. It prolongs disk life and reduces dust exposure.

Keep pressure on the saw reasonably light. Although more pressure may be necessary for hard materials, it can cause an abrasive disk to chip or go "out of round." This in turn will make the saw vibrate. If lowering the feed pressure does not stop vibration, replace the disk.

Don't carry the saw any distance with the engine running. Stop the engine and carry the saw with the muffler away from you.

To avoid kickback, take the following steps:

- Secure and support the material at a comfortable position for cutting. Make sure that material will not move, shift, or pinch the blade or disk during cutting.
- Keep steady balance and solid footing when making a cut.
- Do not support the work on or against your foot or leg.
- Use both hands to control the saw. Maintain a firm grip with thumb and fingers encircling the handles.
- Never let the upper quarter segment of blade or disk contact the material.
- Run the saw at full throttle.
- Do not cut above chest height.
- When reentering a cut, do so without causing blade or disk to pinch.

Pull-in occurs when the lower part of the disk or blade is stopped suddenly – for instance, by a cut closing up and binding. The saw pitches forward and can pull the operator off balance.

Protective Equipment

In addition to the standard equipment mandatory on construction sites, operators of quick-cut saws should wear snug-fitting clothing, hearing protection, eye and face protection, and heavy-duty leather gloves (Figure 173).

The dry cutting of masonry or concrete products calls for respiratory protection as well. See the chapters on personal protective equipment in this manual.

For general dust hazards, a half-mask cartridge respirator with NIOSH-approval for dust, mist, and fumes should provide adequate protection when properly fitted and worn by a clean-shaven person.

Disks and Blades

Disks and blades are available in three basic types:

- abrasive disks

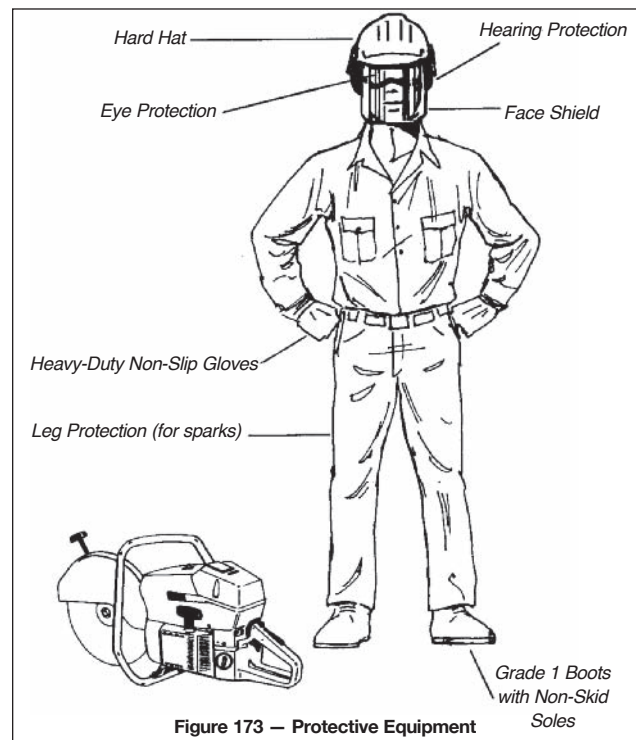


Figure 173 – Protective Equipment

- diamond-tipped blades
- carbide-tipped blades.

Use only the disks and blades compatible with your saw and rated for its maximum rpm. Blades or disks may fly apart if their rpm is not matched to saw rpm. If you have any doubts, consult the operating manual or a reputable supplier.

Abrasive Disks – Types and Uses

Type	Uses	Materials
Concrete	All-around use, most economical for cutting concrete and masonry. Water-cooling recommended to increase disk life and reduce dust.	Concrete, stone, masonry products, cast iron, aluminum, copper, brass, cables, hard rubber, plastics.
Metal	Primarily for steel, not suited for masonry products. Water-cooling is not recommended with metal abrasive disks.	Steel, steel alloys, other hard metals such as cast iron.

Diamond Disks and Blades

Diamond disks are normally used with water cooling. They are now available for dry cutting, which may be necessary to avoid staining some masonry products.

When dry-cutting with a diamond blade, let the blade cool for 10-15 seconds every 40-60 seconds. This can be done simply by pulling the saw out of the cut.

Types and Uses

Type	Uses	Materials
Diamond Abrasive Disk	Cuts faster than other abrasive disks and creates less dust. Water-cooling is absolutely necessary to prevent heat build-up that can make disk disintegrate.	Stone, all masonry and concrete products. Not recommended for metals.
Dry-Cut Diamond Blade	Fast cuts, lots of dust, very expensive. Let blade cool for 10-15 seconds every 40-60 seconds. Continuous cutting will damage the blade.	Stone, all masonry and concrete products. Not recommended for metals.

Carbide-Tipped Blades

These blades must be used with care. If a carbide-tipped blade encounters material harder than what it is designed to cut, the tips may fly off.

A carbide-tipped blade used with a quick-cut saw **must** be designed for that purpose. It must also be used only to cut the materials specified by the manufacturer.

Inspection/Installation

Inspect disks and blades before installing them.

- Make sure that contact surfaces are flat, run true on the arbor, and are free of foreign material.
- Check that flanges are the correct size and not warped or sprung (Figure 174).
- Check the label to make sure that the disk or blade is approved for use on high-speed quick-cut saws and has a rated rpm suitable to the saw being used. A

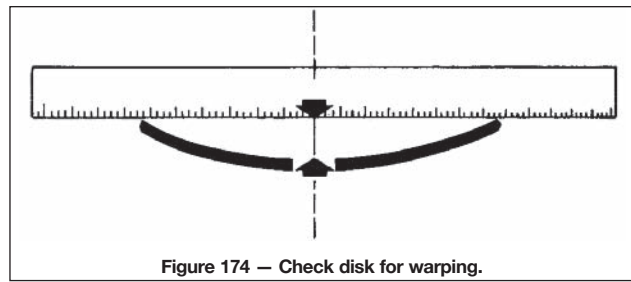


Figure 174 – Check disk for warping.

periodic service check may be necessary to ensure that the rpm still meets the manufacturer's requirement.

- Inspect the disk or blade for damage. Abrasive disks tapped lightly with a piece of wood should ring true. If the sound is dull or flat, the disk is damaged and should be discarded.
- Make sure that diamond or carbide tips are all in place. Do not use diamond or carbide-tipped blades or disks if any tips are missing.
- Do not drop abrasive disks. Discard any disk that has been dropped.
- Use the proper bushing on the arbor so that the disk runs true on the shaft without wobbling or vibrating.
- Discard badly worn disks that are uneven or "out of round."

Table Saws

Types

The table saw most often used in construction is the 10-inch belt-driven tilting arbor saw. The dimension refers to the diameter of the saw blade recommended by the manufacturer.

Although some saws are direct-drive (Figure 175), with the blade mounted right on the motor arbor, most are belt-driven (Figure 176).

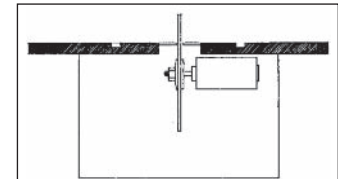


Figure 175 – Direct-Drive Table Saw

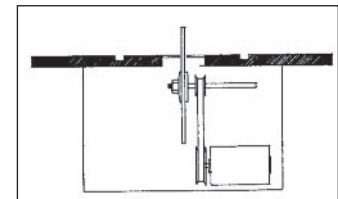


Figure 176 – Belt-Driven Table Saw

Both types are equipped with a fixed table top and an arbor that can be raised, lowered, or tilted to one side for cutting at different depths and angles.

Basket Guards

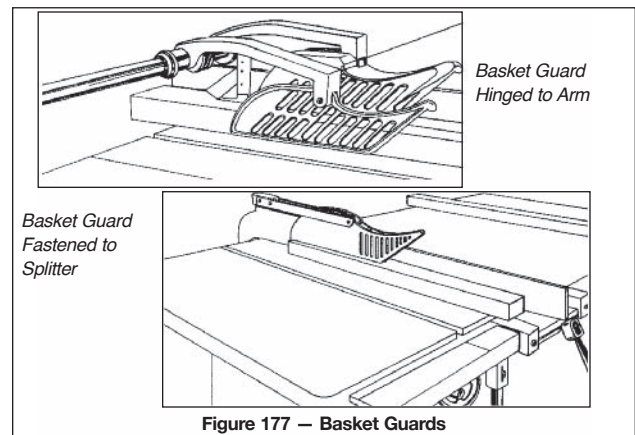


Figure 177 – Basket Guards

Basket guards may be fastened to the splitter or hinged to either side of the saw on an L-shaped or S-shaped arm (Figure 177).

Basket guards can protect the operator from sawdust, splinters, and accidental contact with the blade. Keep the basket guard in place for normal operations such as straight and bevel ripping and mitre cutting. When the guard is removed to permit cutting of tenons, finger joints, rabbets, and similar work, use accessories such as feather boards, holding jigs, push sticks, and saw covers.

Figure 178 shows a split basket guard with a see-through cover. One side can be moved sideways for a blade tilted to 45 degrees. One side can be lifted up while the other remains as a protective cover.

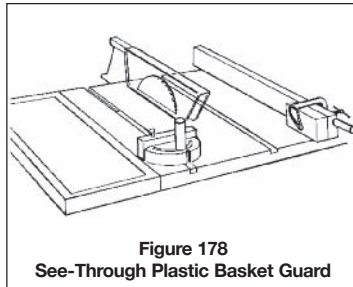


Figure 178
See-Through Plastic Basket Guard

Sheet metal baskets fastened to the splitter are less effective because the operator cannot see the saw blade.

Kickback

Kickback occurs when stock binds against the saw blade. The blade can fire the wood back at the operator with tremendous force, causing major injuries to abdomen, legs, and hands.

- Never stand directly behind the blade when cutting. Stand to one side. See that other workers stand clear as well.
- Make sure the rip fence is aligned for slightly more clearance behind the blade than in front. This will help prevent binding.
- Use a sharp blade with teeth properly set for the wood being cut. A dull or badly gummed blade will cause friction, overheating, and binding.
- Install a splitter to keep the kerf (cut) open behind the blade. Also effective are anti-kickback fingers attached to the splitter.

Splitters

Splitters prevent the kerf from closing directly behind the blade. Ideally, they should be slightly thinner than the saw blade and manufactured from high tensile steel.

Splitters are not always needed with carbide-tipped saw blades, whose relatively wide kerf may provide the desirable clearance. A wide kerf alone, however, is often not enough to keep some boards from closing behind the cut and binding against the blade.

In general, it is impossible to predict how a board will behave during ripping. It may remain straight, presenting no problems. On the other hand, the release of internal stresses may make the two ripped portions behind the blade either close up or spread apart.

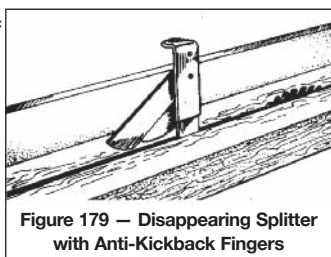


Figure 179 — Disappearing Splitter with Anti-Kickback Fingers

Figure 179 shows a disappearing splitter with

anti-kickback fingers. It can be pushed down when in the way of a workpiece and pulled up when necessary after the machine has been shut off.

Roller Stand

Operators risk injury trying to maintain control over long pieces of stock singlehandedly, especially if the stock begins to bind on the blade and kick back.

A roller stand (Figure 180) provides the needed support. Adjust it to a height slightly lower than the saw table to allow for sagging of the material. Be sure to set up the stand so the roller axis is at 90 degrees to the blade. Otherwise, the roller could pull the stock off to one side and cause binding.

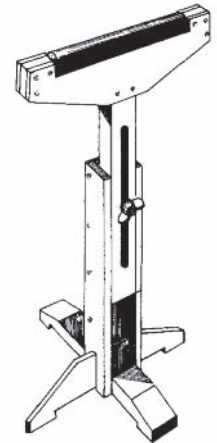


Figure 180 — Roller Stand

Whatever the design, a support stand should be standard equipment in every carpentry and millwork shop. It can be used as an extension to a workbench, jointer, or bandsaw and is especially important with the table saw.

Extensions

Made of wood or metal, table top extensions installed behind and to both sides of the machine can make the cutting of large sheets of plywood and long stock safer and more efficient.

In most cases a space must be provided between extension and saw top for adjusting the basket guard and allowing scrap to fall clear.

Blades

Table saw blades are basically similar to those for circular saws.

The teeth on carbide-tipped, hollow-ground, and taper blades do not need setting (Figure 181).

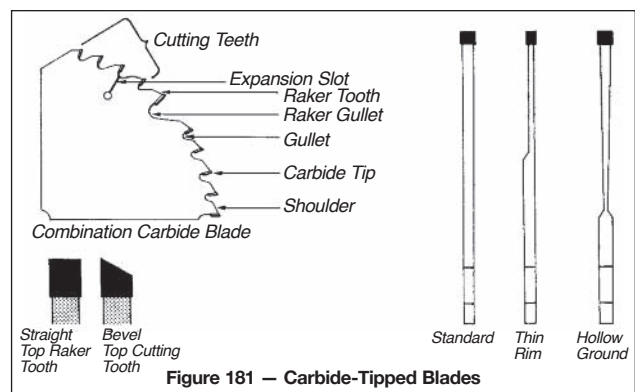


Figure 181 — Carbide-Tipped Blades

Blade Adjustment

Proper adjustment of cutting depth holds blade friction to a minimum, removes sawdust from the cut, and results in cool cutting.

Sharp blades with properly set teeth will keep the work from binding and the blade from overheating and kicking back.

The blade should project the depth of one full tooth above the material to be cut. When using carbide-tipped blades or mitre blades let only half a tooth project above the material.

Blade Speed

The right cutting speed is important. The blade should turn at the correct rpm to yield the recommended cutting speed.

When not in motion, saw blades, especially large blades, are usually not perfectly flat because of internal tensions. At the right operating speeds, however, the blades straighten out as a result of centrifugal force and cut smoothly at full capacity.

Blades running too fast or too slow tend to start wobbling either before or during a cut. If cutting continues, the blade will overheat and may cause kickback, damage the equipment, and injure the operator.

Rip Fence

The rip fence is used mainly to guide the stock and maintain correct width of cut. The fence on small saws is usually clamped down at both the front and back of the table by pushing down a lever or turning a knob. Adjust the fence slightly wider at the back to let the wood spread out behind the cut and reduce the risk of kickback.

Many carpenters add a piece of hardwood to the rip fence in order to rip thin pieces of wood and make dadoes and rabbets. The auxiliary fence can be set close to the cutters without the risk of contact between the blade and the steel fence.

Pushsticks

Narrow pieces can be cut safely and efficiently with the help of pushsticks (Figure 182), which should be painted or otherwise marked to prevent loss.

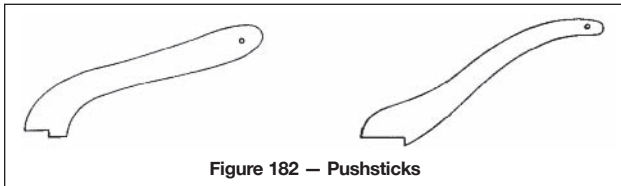


Figure 182 — Pushsticks

To rip narrow, short pieces, a push block is the right choice (Figure 183). The shoe holds the material down on the table while the heel moves the stock forward and keeps it from kicking back.

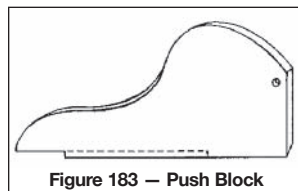


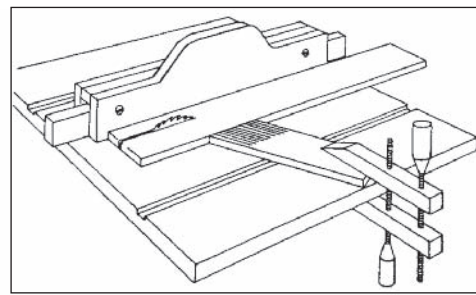
Figure 183 — Push Block

Different designs of pushsticks are required for cutting different kinds of stock.

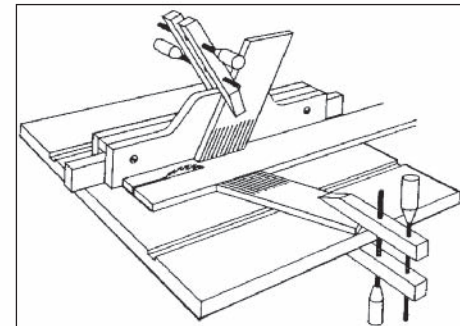
The heel of the pushstick should be deep enough to prevent it from slipping and strong enough to feed the stock through the saw.

Feather Boards

You can also use one or two feather boards (Figure 184) to rip narrow stock safely. A feather board clamped immediately in front of the saw blade will provide side pressure to the stock without causing binding and kickback. Use a push block to feed stock all the way through.



Clamp feather board in front of saw blade.



Clamp second feather board to auxiliary rip fence.

Figure 184 — Feather Boards

Operation

- Follow **Basic Saw Safety** (at the beginning of this chapter).
- Keep the floor around the saw clear of scrap and sawdust to prevent slipping and tripping.
- Always stop the machine before making adjustments. Before making major adjustments, always disconnect the main power supply.
- Select a sharp blade suitable for the job.
- Use the safety devices such as pushsticks and feather boards recommended in this chapter.
- Make sure nobody stands in line with a revolving blade.
- Don't let anyone or anything distract you when you are operating the saw.
- Whenever possible, keep your fingers folded in a fist rather than extended as you feed work into the saw.
- Never reach around, over, or behind a running blade to control the stock.
- Follow the manufacturer's recommendations in matching the motor size to the saw. Underpowered saws can be unsafe.
- Table saws should be properly grounded. Check the power supply for ground and always use a ground fault circuit interrupter. This is mandatory for saws used outdoors or in wet locations.
- Table saws should be equipped with an on-off switch so power can be shut off quickly in an emergency.
- A magnetic starter switch is preferable to a mechanical toggle because it prevents the saw from starting up again unexpectedly after an interruption in power.
- When purchasing a new table saw, try to get one equipped with an electric brake. The brake stops blade rotation within seconds of the operator turning off the saw. The reduced risk of injury is worth the extra cost.
- Extension cords should be of sufficient wire gauge for the voltage and amperage required by the saw and for the length of the run.

Radial Arm Saws

The motor and blade of the radial arm saw are suspended above the table (Figure 185). Because the motor and blade assembly can be locked in different positions and can travel during the cut, the operator must pay special attention to keeping fingers and hands clear.

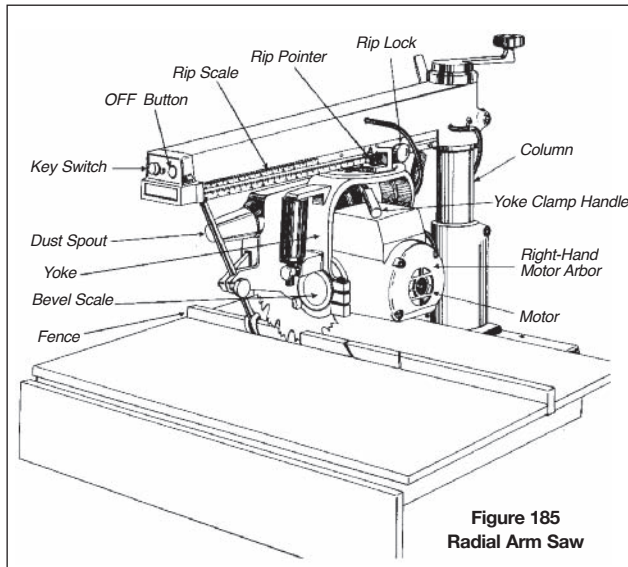


Figure 185
Radial Arm Saw

Injuries involving radial arm saws tend to be serious. By using appropriate guards and procedures, however, operators can safely use the saw for crosscuts, mitre cuts, ripping, and dados.

Set-Up

- The saw must be adequately powered for the work, especially for cutting thick hardwood.
- The saw should be installed in a well-lit area out of the way of traffic, with enough space to store and handle long lengths of wood. Locating the machine with its back to a wall or partition can help to keep flying pieces from hitting anyone.
- Where possible, mark the floor with yellow warning lines to keep other personnel back from the saw.
- Make sure all safety guards and devices are in place.
- Choose the right blade for the job. A sharp tungsten carbide combination blade is good for both crosscutting and ripping without frequent resharpening. For information on blade types and uses, refer to earlier sections of this chapter.

General Procedures

- Follow **Basic Saw Safety** (at the beginning of this chapter).
- If you don't have someone to help with long stock, use a roller stand or extension table to support the work.
- Always return the motor head to the column stop.
- When crosscutting or mitring, keep hands at least six inches away from the blade. **Do not adjust length of cut until the motor is back at column.**
- Slope the table top back slightly to keep the blade at the column, thereby preventing contact with stock being placed in position.
- Do not allow the blade to cut too quickly when crosscutting or mitring.

- Avoid drawing the blade completely out of the cut. The cut piece, whether large or small, often moves. When the saw is rolled back towards the column, the teeth can grab the piece and shoot it in any direction.
- Do not cut by pushing the saw away from you into the stock. The material can lift up and fly over the fence.

Ripping and Crosscutting

- For regular ripping, turn the motor away from the column to the in-rip position. Feed stock into the saw from the right side.
- To cut wide stock, change the saw to the out-rip position. Feed stock into the saw from the left side. Operators accustomed to in-ripping may find this set-up awkward. Remember – the blade must turn **up and toward** the person feeding the stock.
- Do not force the cut. Allow the blade through the wood at its own pace.
- **To avoid kickback, take the following precautions.**
 - Maintain proper alignment of blade with fence.
 - Adjust anti-kickback device (Figure 186) to 1/8 inch below the surface of stock being fed.

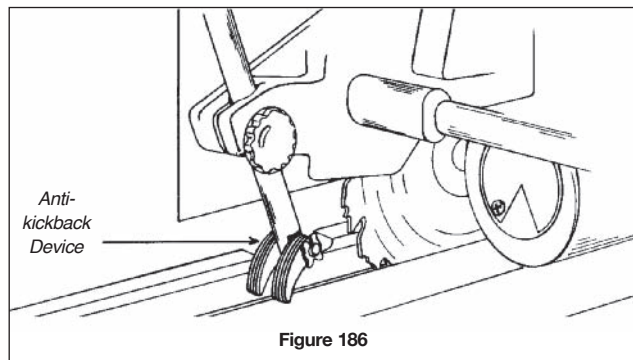


Figure 186

- Use a sharp blade, free of gum deposits and with teeth properly set.
- When binding occurs, stop saw and open kerf with a wedge.
- After completing cut, remove stock from rotating blade to prevent overheating and possible kickback.
- Always push stock all the way through past the blade.
- Do not leave machine with motor running.
- Use a push stick when ripping narrow pieces. Have suitably sized and shaped pushsticks for other jobs as well.

See information on pushsticks and feather boards under Table Saws, earlier in this chapter.

Jigs

The control provided by a well-made jig is essential for making irregular cuts safely and accurately.

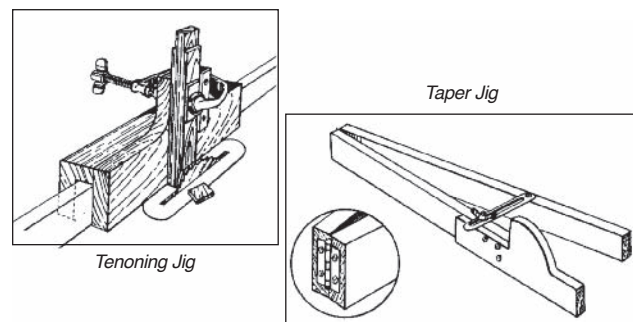


Figure 187 – Jigs

Keep commonly used jigs (Figure 187) on hand. Jigs such as those for making stair and doorframe wedges and tapers are designed to carry stock past the blade with the saw locked in the rip position.

When you're drawing the saw into the stock, clamp or nail jigs to the table to prevent slipping.

Re-Sawing with Blade Horizontal

The rip fence on the radial arm saw is too low for supporting material to be re-sawn on edge. Therefore the material must be laid flat on the table and the motor must be turned so the blade is parallel to the table. The closeness of the arbor requires an auxiliary table top and fence to re-saw thin stock.

Because the kickback fence can't be used and controlling stock is sometimes difficult, re-sawing on the radial arm saw can be hazardous.

If no other equipment is available, rip the stock halfway through, then turn it around and complete the cut.

On the second cut, be sure to push the two halves well past the blade once they have been cut apart. Pushsticks and featherboards clamped to the table can reduce hazards.

Dadoes

A dado head is an essential tool for cutting grooves, rabbets, and dadoes. A groove is cut with the grain; a dado is cut across the grain; and a rabbet is a shoulder cut along the edge of a board.

The most common dado head consists of two outside cutters and several inside chippers between the outside cutters (Figure 188).

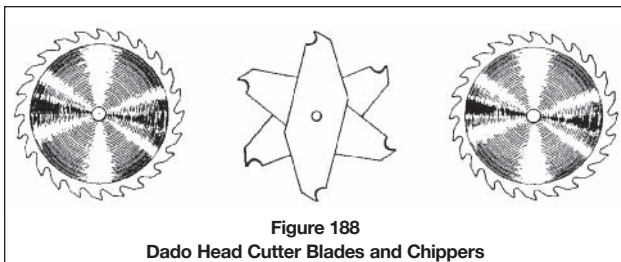


Figure 188
Dado Head Cutter Blades and Chippers

Another type is sometimes called a quick-set dado, consisting of four tapered washers and a blade. By rotating the locking washers, the blade will oscillate and cut a groove to the desired width.

Because of their small size, dado heads do not run at the peripheral feed speed on a big radial arm saw. As a result, the blade feeds itself too fast, either stopping the motor or lifting the work and throwing it back. To prevent this, **make several light passes**, lowering the dado head 1/8 to 1/4 inch each time.

Dado heads require guards for safety. Always make sure guards are in place before starting work.

Proper rotation of the teeth is **up and toward** you.

Other Accessories

Rotary accessories of various types are advertised as turning the radial arm saw into a multifunction machine. Operators should remember that the saw has its limitations. Possible problems include the following.

- Shaper heads run too slow for safe and smooth work.
- Grinding stones may run too fast or slow and are not recommended.
- Sanding drums tend to run too fast and may burn the wood.

39 POWER TOOLS — AIR

Many different types of tools are powered by compressed air. They are fast, powerful, and ideal for repetitive tasks such as the nailing of large areas of roof decking or chipping and breaking concrete. A compressor, powered by a combustion or electric motor, supplies the air for the tools.

Air-powered tools include

- jack hammers
 - chipping hammers
 - drills
 - grinders
 - sanders
 - staplers
 - framing nailers
 - wrenches
 - brad nailers
 - winches
 - air nozzles
 - saws
 - buffers
 - impact tools
 - sprayers.
- Run combustion engines outside or in a well-ventilated area to prevent the build-up of carbon monoxide gas. Always keep a fire extinguisher near flammable liquids.
 - When moving compressors to another location, ask for help or use mechanical devices to prevent back injuries.
 - Occasionally workers suffer eye injuries when compressed air is used to blow out formwork. Wear safety goggles and respiratory protection.
 - Always secure hose connections with wire or safety clips to prevent the hose from whipping except when automatic cut-off couplers are used.
 - Make sure hoses are clear of traffic and pose no tripping hazards.
 - Replace worn-out absorption pads and springs. Too much vibration of the tool can damage nerves in fingers, hands, and other body parts. This is called “white finger disease” or Raynaud’s Syndrome.
 - Some tools have a high decibel rating – for instance, jack hammers and impact drills. To prevent hearing loss, always wear hearing protection.
 - Never tamper with safety devices.
 - Keep hands away from discharge area – on nailers in particular.
 - Match the speed rating of saw blades, grinding wheels, cut-off wheels, etc. to tool speed. Too fast or too slow a rotation can damage the wheels, release fragments, and injure workers.
- Never use air to blow dust or dirt out of work clothes. Compressed air can enter the skin and bloodstream with deadly results.
- Turn off the pressure to hoses when the system is not in use.
 - Turn off the air pressure when changing pneumatic tools or attachments.
 - Never “kink” a hose to stop air flow.

Most air-powered tools need very little maintenance. At the end of the shift, put a teaspoon of oil in the air inlet and run the tool for a second or two to protect against rust.

Dust, moist air, and corrosive fumes can damage the equipment. An inline regulator filter and lubricator will extend tool life.

Before start-up, check the couplings and fittings, blow out the hose to remove moisture and dirt, and clean the nipple before connecting the tool. Set the air pressure according to the manufacturer's specifications and open gradually.

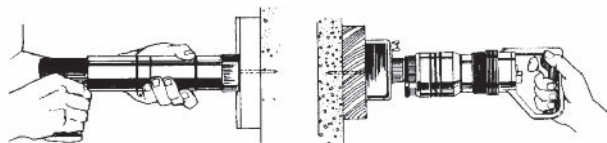
Compressed air can be dangerous. Hazards include

Air embolism	This is the most serious hazard, since it can lead to death. If compressed air from a hose or nozzle enters even a tiny cut on the skin, it can form a bubble in the bloodstream – with possibly fatal results.
Physical damage	Compressed air directed at the body can easily cause injuries – including damage to eyes and ear drums.
Flying particles	Compressed air at only 40 pounds per square inch can accelerate debris to well over 70 miles per hour when it is used to blow off dust, metal shavings, or wood chips. These particles then carry enough force to penetrate the skin.

WARNING: Make sure that air pressure is set at a suitable level for the tool or equipment being used. Before changing or adjusting pneumatic tools, turn off air pressure.

40 POWER TOOLS — EXPLOSIVE

Referred to as explosive-actuated or powder-actuated, these tools use a powder charge to fire a fastener into hard materials such as concrete, mild steel, and masonry. Used improperly, powder-actuated tools pose obvious hazards. The tools should be treated with the same respect as a firearm. Most jurisdictions – including Ontario – require that operators be trained before using the tools and carry proof of training on the job.



Hazards

Flying Particles – This is the major hazard. On impact, materials may break up, blow apart, or spall off. This often happens when fasteners are fired too close to a corner of masonry or concrete or when they strike materials such as glazed tile, hollow tile, or thin marble tile.

Ricochets – These usually result when the tool is not held at right angles to the base material, or the fastener hits a particularly hard material such as stone or hardened steel. Always check the base material to ensure that it can safely accept the fastening device.

Noise – Powder-actuated tools create an extreme pulse of sound when fired. Operators and others in the area should wear hearing protection – especially when the tool is operated in a confined space.

Sprains and Strains – These injuries usually result from using the tool repeatedly in awkward, cramped, or unbalanced positions. Operators should try to work from a balanced position on a solid surface.

Explosions – There is always the risk of explosion or fire when the tools are used in atmospheres contaminated by flammable vapour, mist, or dust. The work area must be ventilated – mechanically if necessary.

Blow-Through – When the base material does not offer enough resistance, the fastener may pass completely through and fly out the other side. This is particularly dangerous when fasteners penetrate walls, floors, or ceilings where others may be working. If necessary, areas behind, around, and under material should be kept clear of people.

Protective Equipment

In addition to the standard personal protective equipment required on construction projects (see the chapters on personal protective equipment in this manual), the operator of a powder-actuated tool should wear hearing protection, eye protection, and a face shield. Heavy shirts and pants provide some protection against ricochets and flying fragments of material and fasteners.

Tool Types

High-Velocity — High-velocity powder-actuated tools use the expanding gases from the exploding cartridge to propel the fastener. The gases push directly against the

fastener. These tools are rarely used in construction, except in special cases to penetrate thick steel or very hard material — they are usually used in military, salvage, or underwater applications. No one should operate high-velocity tools without special training.

Low-Velocity — Most powder-actuated tools used in construction are low-velocity. The expanding gases from the exploding cartridge push against a piston which in turn drives the fastener into the base material.



Many different low-velocity tools are available, from single-shot models to semi-automatic models using multiple cartridges in strip or disk holders. Some tools are specific to one size of fastener or type of cartridge. Most can be fitted with various pistons, base plates, spall stops, and protective shields for different jobs.

Pistons

Specialized pistons are available for different fasteners. Such pistons are designed for the fastener and should not be used with other types. Misusing a tool with a specialized piston can result in under- or over-driven fasteners or fasteners leaving the barrel misaligned, leading to ricochets. Some general-purpose tools can take various types of pistons.

Fasteners

Fasteners used with powder-actuated tools are made of special steel to penetrate materials without breaking or bending. Never use any kind of substitute for a properly manufactured fastener.

Generally pins and studs should not be used on hard, brittle, or glazed materials such as cast iron, marble, tiles, and most stone. The fastener will either fail to penetrate and ricochet or the base material will shatter.

Materials whose hardness or ductility is unknown should be tested first. Try to drive a pin into the material with a normal hammer. If the pin point is blunted or fails to penetrate at least 2 mm (1/16"), a powder-actuated tool should **not** be used.

Fasteners are invariably fitted with a plastic guide device. Its purpose is twofold. When the fastener is inserted into the barrel the guide keeps the fastener from dropping out. It also aligns the fastener inside the barrel so it will penetrate the base material at right angles.

There are two basic types of fasteners – pins and studs.

Pins are fasteners designed to attach one material to another, such as wood to concrete. They resemble nails, but there the similarity stops. Ordinary nails cannot be used as fasteners in powder-actuated tools.

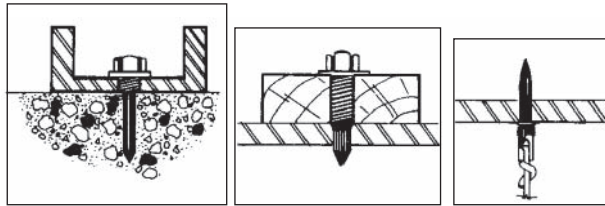
Head diameters for pins are available between 7 mm (1/4") and 9 mm (3/8"). Lengths vary from 12 mm (1/2") to 76 mm (3"). Washers of various types and diameters are available for different applications.

Pins should be selected for appropriate length, head size, and application. As a general rule, pins need not be driven into concrete more than 25 mm (1"). Using a longer pin is generally unnecessary and also requires a stronger cartridge.

Follow the manufacturer's directions on length, penetration, and appropriate material. For example, one cut-nail fastener is available for fastening drywall to relatively soft base materials, but is recommended for virtually no other application. Testing may be necessary on some masonry materials that vary widely in hardness and durability.



Studs are fasteners consisting of a shank which is driven into the base material and an exposed portion to which a fitting or other object can be attached. The exposed portion may be threaded for attachments made with a nut. Studs are also available in an eye-pin configuration for running wire through the eye.



Clip Assemblies - Fastening to the base material is done by a pin, but the pin is attached to a clip assembly configured to secure a uniquely shaped item. Clip assemblies are available, for instance, to hold conduit. One ceiling configuration comes with pre-tied 12 gauge wire.



Cartridges

Manufacturers recommend certain cartridges for certain applications. Because recommendations cannot cover every possibility, testing may be required with unfamiliar base materials.

Cartridges come in .22, .25, and .27 calibre sizes. Larger calibres hold more powder which drives the fastener further – or into harder base materials. In addition, all three calibres are available with different levels of powder charge. For some tools there may be as many as six different powder charges available. Some manufacturers produce tools that use a long-case version of the .22-calibre cartridge. It is critical that operators understand cartridge selection and cartridge identification systems.

COLOUR	NUMBER	CARTRIDGE POWER
Grey	1	Lowest
Brown	2	
Green	3	
Yellow	4	
Red	5	
Purple	6	Highest

Shots may be packaged/loaded as single cartridges, strips of ten in a plastic holder, or a round disk holding ten cartridges. The tool model will determine the calibre and how the tool is to be loaded.

Number identifications are printed on the outside of cartridge packages. Cartridge tips are colour-dipped for identification. Some strip cartridges are held in a plastic strip the same colour as the cartridge tips.

The general rule is to start with the weakest cartridge and increase one cartridge colour/load number at a time to reach the penetration required. Too strong a charge may cause shattering, ricochets, or blow-through. Too weak a cartridge will keep the fastener from seating itself properly.

Tool Power Controls

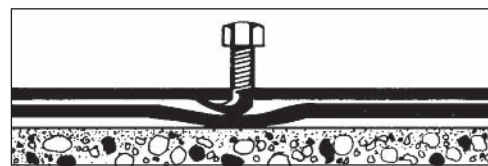
Many tools feature a “power control” device. This allows an operator to make a tool adjustment so that either all or only part of the available cartridge power is used. Power controls may ultimately let manufacturers market only one cartridge in each calibre. The goal would be to handle every application which the calibre is capable of performing with one cartridge, power-controlled to the appropriate driving force needed.

Fastening Steel

Low-velocity powder-actuated tools should not be used on hardened steels, tool steels, or spring steels. Where the grade of steel is unknown, test by trying to hammer the fastener in. If the pin is blunted, bent, or fails to enter at least 2 mm (1/16"), do not use a low-velocity powder-actuated tool – it's not up to the job.

Don't try to fire a fastener any closer than 13 mm (1/2") to the free edge of steel. Keep in mind that this applies only to steel. When fastening steel to concrete, you must consider the allowable margin for concrete as well: 63 mm (2 1/2").

When fastening two pieces of thin sheet steel to a base material, hold the sheets together. Gaps caused by bending may lead to ricochets.

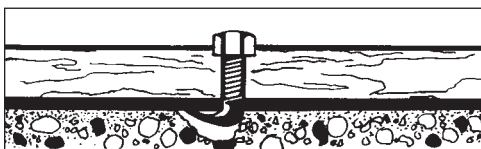


Special spall stops or protective shields are required for applications such as fastening sheet metal to masonry or sheet metal to structural steel. Consult the operating manual or the manufacturer to ensure that the right components are being used for the job.

Fastening Concrete and Masonry

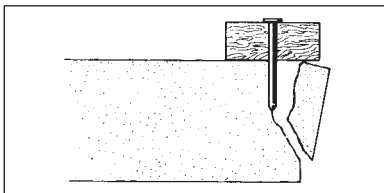
Concrete and masonry materials are not always uniform in consistency or hardness. As a result, they may spall, chip, or cause a ricochet when the fastener strikes a spot or layer harder than the rest. Use the spall guard recommended by the manufacturer.

Once material is spalled or left with a ricochet hole, do not fire a second pin any closer than 50 mm (2") to the damaged area. The area may be weakened and spall further or cause a ricochet off its sloped edge.



Ricochet off a sloped edge.

Pins tend to cause breaks near the edges of concrete and masonry. Don't drive pins closer than 63 mm (2½") to a free edge.



Misfires

With misfired cartridges, follow the procedures stated in the operating manual for the tool you are using. Because of the wide variety of tools available, procedures for misfires may differ. When such information is not available, take the following steps.

- Continue to hold the tool against the base material for at least 30 seconds. This protects against a delayed discharge of the cartridge.
- Remove the cartridge from the tool. During removal keep the tool pointed safely toward soft material such as wood. Never use any kind of prying device to extract the cartridge from the chamber. If the cartridge is wedged or stuck, tag the tool "DEFECTIVE and LOADED" and lock it in its storage container. Never try to dismantle a tool with a cartridge stuck or wedged in it. Again, tag it "DEFECTIVE and LOADED," lock it away, and call the manufacturer's representative for help.
- Regulations require that a misfired cartridge be placed in a container of water.
- Keep the misfired cartridge separate from unused cartridges and return it to the manufacturer for disposal. Never throw misfired cartridges in the garbage.
- Be cautious. The problem may be a misfired cartridge, but the tool may also be defective. Check the tool for obvious damage, perform function tests, and use the tool only if it operates properly.

General Safeguards

- Workers who pick up a powder-actuated tool must immediately prove to themselves that the tool is not loaded. This action must become instinctive and be carried out before anything else is done with the tool. Even after watching someone else handle the tool before passing it on, make sure that it's not loaded.
- Powder-actuated tools should be used, handled, and stored properly.
- Never put your hand or fingers over the end of the muzzle for any reason, even when the tools are not loaded with fasteners.
- Tools must be inspected and function-tested before work starts. Proper training and the operator's manual will describe how to carry out both of these requirements.

- Operators must be trained on the powder-actuated tools they are using and must wear all the required personal protective equipment.
- Fasteners should not be fired through pre-drilled holes for two reasons:
 - 1) Unless the fastener hits the hole accurately, it will probably shatter the edge.
 - 2) The fastener derives its holding power from compressing the material around it. A pre-drilled hole reduces this pressure and therefore the fastener's holding power. (This is why studs and pins driven into steel should penetrate completely through the metal. Otherwise the compressed steel trying to regain its original position can loosen the fastener by pushing against the point. With the tip completely through the metal the same pressure only works to squeeze the pin tighter.)
- Firing explosive-actuated tools from ladders is not recommended. From a ladder it can be difficult to press the tool muzzle against the base material with enough pressure to fire. For tasks overhead or at heights, work from a scaffold or another approved work platform to ensure solid, balanced footing. As an alternative use a manufacturer's pole accessory if the reach is normal ceiling height (8-10 feet). The pole secures the tool and permits firing by the operator standing below.
- Do not leave the tool unattended unless it's locked in a box.
- Load the tool immediately before firing. Don't walk around with the tool loaded.
- Do not use powder-actuated tools in areas where there may be exposure to explosive vapours or gases.

Maintenance

Tools in regular use should be cleaned daily. Tools used intermittently should be cleaned after firing.

All parts of the tool exposed to detonation gases from the cartridge should be cleaned and lightly oiled according to the manufacturer's instructions. The cartridge magazine port, cartridge chamber, and piston sleeve should be wiped clean but **never** be oiled.

The tool brush supplied is adequate for most fouling. Stubborn carbon should be loosened with a manufacturer's spray detergent oil. Tools being checked for immediate use should be wiped dry of oil.

Failure to clean the tool as recommended can lead to corrosion, pitting, fouling, and failure to work properly. Ideally, the tool should be cleaned before being returned to storage.

Tools with a power control adjustment will accumulate additional powder residue from firing—especially when the control is set to restrict the amount of cartridge strength being used. Semi-automatic tools may also accumulate powder residue. These tools need to be cleaned more often.

Sluggish performance may indicate that a tool needs cleaning. Tool action will slow to the point where a competent operator can detect the difference. Most manufacturers recommend major maintenance, inspection, and cleaning every six months. This involves stripping, inspecting, and cleaning parts not covered in daily maintenance.

Storage

Regulations require that both the tool and the cartridges be stored in a locked container with explosive loads of different strengths in separate containers. Cartridges should only be removed from the locked container when they are going to be used immediately.

Regulations

- Any worker using an explosive-actuated tool must be instructed in its safe and proper use.
- Before using the tool, the operator must check to ensure that it is in good working order. This means inspection and function testing.
- Tools firing fasteners at a velocity of more than 90 metres/second must have a protective guard at least 75 mm in diameter, mounted at right angles to the barrel of the tool and centered on the muzzle end of the tool, if practical.
- The tool must require two separate actions before it will fire:
 - 1) pressure against the surface of the material
 - 2) action of the trigger.
- Explosive-actuated tools must be stored in a locked container when not in use or when left unattended.
- The tool must not be loaded until ready for immediate use.
- Whether loaded or unloaded, the tool must never be pointed at anyone.
- Cartridges must be marked or labelled for easy identification. Cartridges of different strengths must be stored in separate containers.
- Misfired cartridges must be placed in a container of water and be removed from the project.

41 WELDING AND CUTTING

Welding is a process which uses heat and/or pressure to join metals.

Arc welding is by far the most commonly used in construction. Molten metal from the workpiece and a filler metal from an electrode form a common puddle which cools to form a weld.

Flame cutting is an allied process that requires the use of a torch, fuel gas, and oxygen to cut metals — primarily steel.

For some of the information in this chapter, the Construction Safety Association of Ontario gratefully acknowledges its use of the Canadian Standards Association standard CAN/CSA-W117.2 *Safety in Welding, Cutting and Allied Processes*, copyright CSA.

Welding Methods

Shielded Metal Arc Welding (SMAW) is the most common arc welding process in construction (Figure 20.1).

SMAW uses a short length of consumable electrode which melts as it maintains the arc. Melted metal from the electrode is carried across the arc to become the filler metal of the weld.

The electrode is coated with a complex mix of chemicals that releases a shielding gas such as carbon dioxide to keep air out of the arc zone and protect the weld from oxidation. The composition of the coating varies with the metal being welded.

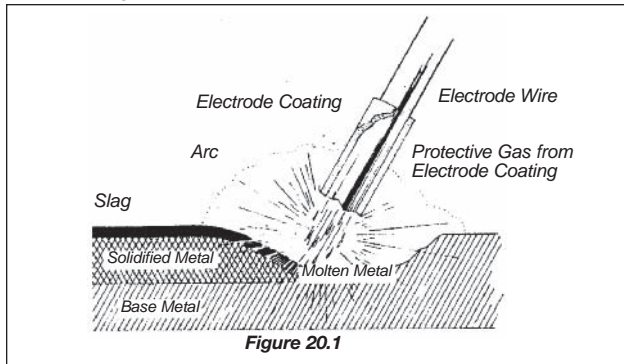


Figure 20.1

Gas Metal Arc (GMAW) or Metal Inert Gas Welding (MIG) uses an uncoated consumable wire that is fed continuously down the middle of the welding torch. A ring-like tube

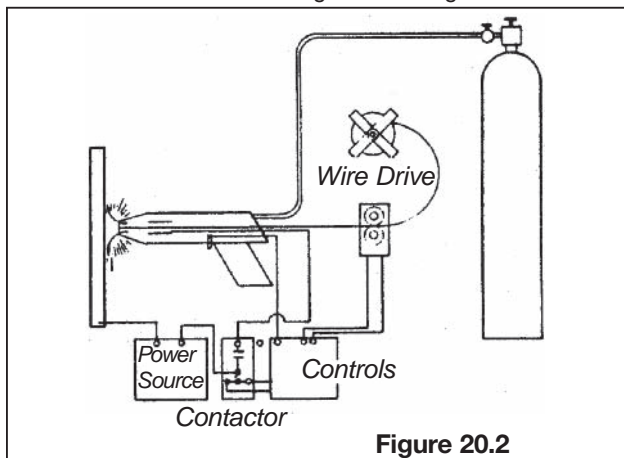


Figure 20.2

around the wire transports an inert gas such as argon, helium, or carbon dioxide from an outside source to the arc zone to prevent oxidation of the weld (Figure 20.2).

Flux Cored Arc Welding (FCAW)

is a variation of MIG welding. It uses a hollow consumable wire whose core contains various chemicals that generate shielding gases to strengthen the weld (Figure 20.3).

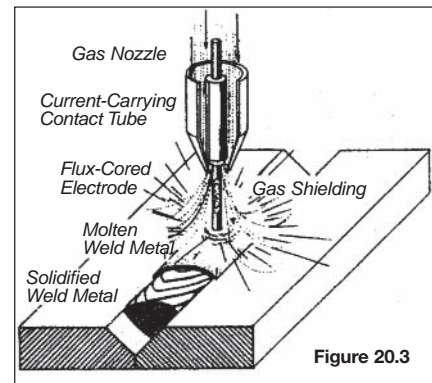


Figure 20.3

Gas Tungsten Arc Welding (GTAW) or Tungsten Inert Gas Welding (TIG)

uses a non-consumable tungsten electrode that maintains the arc and provides enough heat to join metals (Figure 20.4). Filler metal is added in the form of a rod held close to the arc. The rod melts and deposits filler metal at the weld. Shielding gases may or may not be used, depending on the metal being welded.

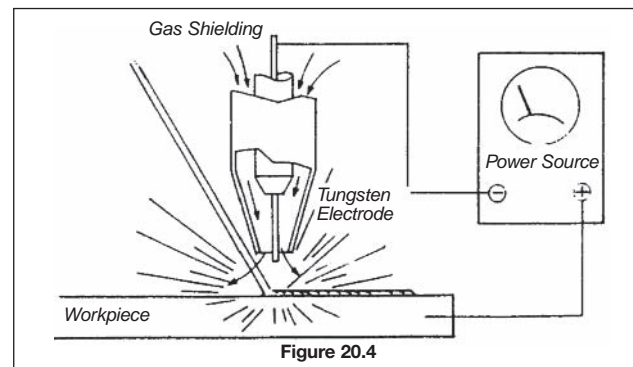


Figure 20.4

Oxyacetylene Welding and Cutting

burns a mixture of gases — oxygen and acetylene — to generate heat for welding metals (Figure 20.5). It's the most common fuel gas cutting and welding used in construction. The process may also employ the use of a filler metal.

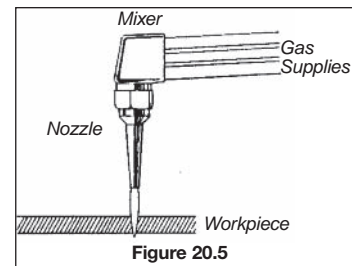


Figure 20.5

ACETYLENE

Acetylene is a mixture of carbon and hydrogen. Its stored energy is released as heat when it burns. When burned with oxygen, acetylene can produce a higher flame temperature (3,300°C) than any other gas used commercially. The wide flammable range of acetylene (2.5% to 81% in air) is greater than that of other commonly used gases, with consequently greater hazard.

OTHER FUEL GASES

Fuel gases for welding are used alone or with oxygen. Examples include propane, propylene, and natural gas.

Types of Base Metals Welded

Mild Steel (an alloy of iron, carbon, silicon, and occasionally molybdenum or manganese).

Stainless and High Alloy Steels (containing iron, nickel, chromium, and occasionally cobalt, vanadium, manganese, and molybdenum).

Aluminum (either pure or as an alloy containing magnesium, silicon, and occasionally chromium).

Galvanized steel (steel that has been coated with a layer of zinc to prevent corrosion).

Welding Hazards

Welders in construction are exposed to a wide range of hazards such as inhalation of toxic fumes and gases, serious burns from hot metal, and electric shocks from welding cable.

Welding Hazards

Physical	- ionizing radiation (x-rays, gamma rays) - non-ionizing radiation (ultraviolet, infrared) - visible light - temperature extremes - noise - electrical energy
Chemical	- flammable/combustible products - welding fumes - toxic gases - dust
Biological	- bacteria - fungi - viruses

Eye protection is a must for welders and others who may be exposed to the welding process.

Once a chemical from welding has entered the body it may have a toxic effect. Effects can range from mild irritation to death and are influenced by a number of factors. Different organs may also be affected, such as the lungs, kidneys, and brain.

The two major types of effects are acute and chronic, as described in the Basic Occupational Health chapter in this manual.

PHYSICAL HAZARDS

Radiation

Both ionizing and non-ionizing radiation may be encountered by welders and their helpers. Ionizing is more hazardous because it can contribute directly to cancer.

Ionizing — A common source is the emission of x-rays and gamma rays from equipment used to gauge the density and thickness of pipes and to check welds.

Non-ionizing — A major source is ultraviolet, infrared, and visible light radiation from sunlight or welding.

Radiation produced by the welding process is mainly non-ionizing, which includes electromagnetic fields, infrared radiation, visible light, and ultraviolet radiation.

Exposure to ultraviolet (UV) radiation can result directly from the arc or from a reflection off bright objects such as shiny metal or white clothing. It can cause “arc eye” when sight is not adequately protected. Eyes become watery and painful anywhere from 2 to 24 hours after exposure. The condition may last 1–5 days but is usually reversible with no lasting effects. However, repeated exposure may result in scar tissue that can impair vision.

UV exposure may also cause a temporary loss of visual sharpness called “fluorescence.”

Skin reddening, commonly known as sunburn, is another hazard of UV exposure. Blistering may occur in extreme cases. Although excessive exposure to UV radiation from the sun has been linked to skin cancer, there are no reports of increased skin cancer rates from welding exposure.

The intensity of UV radiation varies with the type of welding. Generally, the higher the temperature of the welding process the higher the UV radiation.

Infrared radiation is hazardous for its thermal or heating effects. Excessive exposure to the eye may cause damage.

Visible light is released at high intensity by welding. Short-term exposure can produce “flash blindness” in which vision is affected by after-images and temporary blind spots. Repeated exposure to high-intensity visible light can produce chronic conjunctivitis, characterized by red, tearful eyes.

X-rays and gamma rays are invisible forms of *ionizing* radiation used to inspect welds and can be extremely damaging to unprotected parts of the body. Keep well away from any area where this type of testing is under way. X-rays are also produced during electron beam welding. The welding chamber must be completely shielded to confine the x-rays and protect the operator.

Extreme Temperatures

Very high temperatures are caused by the welding process. Gas flames may reach 3,300°C. Metals melt in a range from 260°C to 2,760°C. Welded materials, the work environment, and weather may all be sources of excessive heat which can cause muscle cramps, dehydration, sudden collapse, and unconsciousness.

Welders may suffer frostbite and hypothermia when working in extreme cold climates or with welding gases stored at temperatures as low as -268°C. Exposure to freezing temperatures can lead to fatigue, irregular breathing, lowered blood pressure, confusion, and loss of consciousness. Heat stress and cold stress are both life-threatening and, if not treated in time, can be fatal.

Noise

Sound waves over 85 dBA emitted at high intensity by welding equipment can lead to hearing loss. Noise has also been linked to headaches, stress, increased blood pressure, nervousness, and excitability. See the chapter on Hearing Protection for information on maximum exposures for workers not equipped with hearing protection.

Welding noise is produced by the power source, the welding process, and by secondary activities such as

grinding and hammering. Gasoline power sources may lead to sound exposures over 95 dBA. Arc gouging may produce sound levels over 110 dBA. Grinding, machining, polishing, hammering, and slag removal all contribute to high levels of noise. Substantial hearing loss has been observed in welders.

Electrical Energy

Electrical shock is the effect produced by current on the nervous system as it passes through the body. Electrical shock may cause violent muscular contractions, leading to falls and injuries. It may also have fatal effects on the heart and lungs.

Electrical shock may occur as a result of improper grounding and/or contact with current through damp clothing, wet floors, and other humid conditions. Even if the shock itself is not fatal, the jolt may still cause welders to fall from their work positions.

Electrical burns are an additional hazard. The burns often occur below the skin surface and can damage muscle and nerve tissue. In severe cases, the results can be fatal.

The extent of injury due to electrical shock depends on voltage and the body's resistance to the current passing through it (see the Electrical Hazards chapter in this manual). Even low voltages used in arc welding can be dangerous under damp or humid conditions. Welders should keep clothing, gloves, and boots dry and stay well insulated from work surfaces, the electrode, the electrode holder, and grounded surfaces.

Stray Current

Stray welding current may cause extensive damage to equipment, buildings, and electrical circuits under certain conditions.

CHEMICAL HAZARDS

Chlorinated solvents for degreasing, zinc chromate-based paint for anti-corrosion coatings, cadmium or chromium dusts from grinding, and welding fumes are all classified as chemical hazards.

Arc welders are at particular risk since the high temperatures generated by the arc can release heavy concentrations of airborne contaminants.

Chemical hazards may injure welders through inhalation, skin absorption, ingestion, or injection into the body. Damage to respiratory, digestive, nervous, and reproductive systems may result. Symptoms of overexposure to chemicals may include nosebleeds, headaches, nausea, fainting, and dizziness.

Read the manufacturer's material safety data sheet (MSDS) for information on protective measures for any chemical you encounter in the workplace.

The most common chemical hazards from welding are airborne contaminants that can be subdivided into the following groups:

- fumes
- gases/vapours
- dusts.

The amount and type of air contamination from these sources depends on the welding process, the base metal,

and the shielding gas. Toxicity depends on the concentration of the contaminants and the physiological response of individual workers.

Fumes

Some of the metal melted at high temperatures during welding vaporizes. The metal vapour then oxidizes to form a metal oxide. When this vapour cools, suspended solid particles called fume particles are produced. Welding fumes consist primarily of suspended metal particles invisible to the naked eye.

Metal fumes are the most common and the most serious health hazard to welders. Fume particles may reach deep into the lungs and cause damage to lung tissue or enter the bloodstream and travel to other parts of the body. The following are some common welding fumes.

Beryllium is a hardening agent found in copper, magnesium, and aluminum alloys. Overexposure may cause *metal fume fever*. Lasting for 18–24 hours, the symptoms include fever, chills, coughing, dryness of mouth and throat, muscular pains, weakness, fatigue, nausea, vomiting, and headaches. Metal fume fever usually occurs several hours after the exposure and the signs and symptoms usually abate 12–24 hours after the exposure with complete recovery. Immunity is quickly acquired if exposure occurs daily, but is quickly lost during weekends and holidays. For this reason, metal fume fever is sometimes called "Monday morning sickness."

Long term (chronic) exposure to beryllium fumes can result in respiratory disease. Symptoms may include coughing and shortness of breath. Beryllium is a suspected carcinogen — that is, it may cause cancer in human tissue. It is highly toxic. Prolonged exposure can be fatal.

Cadmium-plated or cadmium-containing parts resemble, and are often mistaken for, galvanized metal. Cadmium coatings can produce a high concentration of cadmium oxide fumes during welding. Cadmium is also found in solders (especially silver solder) and brazes.

Overexposure to cadmium can cause metal fume fever. Symptoms include respiratory irritation, a sore, dry throat, and a metallic taste followed by cough, chest pain, and difficulty in breathing. Overexposure may also make fluid accumulate in the lungs (pulmonary edema) and may cause death. The liver, kidneys, and bone marrow can also be injured by the presence of this metal.

Chromium is found in many steel alloys. Known to be a skin sensitizer, it may cause skin rashes and skin ulcers with repeated exposure. Chromium also irritates mucous membranes in areas such as eyes and nose and may cause perforation of the nasal septa. Inhaled chromium may cause edema and bronchitis.

Lead can be found in lead-based paints and some metal alloys. Lead poisoning results from inhalation of lead fumes from these lead-based materials. The welding and cutting of lead or lead-coated materials is the primary source of lead poisoning for welders. Symptoms include loss of appetite, anemia, abdominal pains, and kidney and nerve damage. Under Ontario law, lead is a **designated substance** requiring special precautions for use and handling.

Nickel is found in many steel alloys including stainless steel and monel. It is a sensitizing agent and in certain

forms is toxic and carcinogenic. Nickel fumes can also produce cyanosis, delirium, and death 4 to 11 days after exposure.

Zinc is found in aluminum and magnesium alloys, brass, corrosion-resistant coatings such as galvanized metal, and brazing alloys. Inhaling zinc fumes during the cutting or welding of these metals may cause metal fume fever.

Vapours/Gases

A gas is a low-density chemical compound that normally fills the space in which it is released. It has no physical shape or form. Vapour is a gas produced by evaporation.

Several hazardous vapours and gases may be produced by welding. Ultraviolet radiation, surface coatings, shielding gases, and rod coatings are primary sources of vapours and gases. Overexposure may produce one or more of the following respiratory effects:

- inflammation of the lungs
- pulmonary edema (fluid accumulation in the lungs)
- emphysema (loss of elasticity in lung tissue)
- chronic bronchitis
- asphyxiation.

Hydrogen fluoride (HF) gas can be released by the decomposition of rod coatings during welding and irritates the eyes and respiratory system. Overexposure can injure lungs, kidney, liver, and bones. Continued low-level exposures can result in chronic irritation of nose, throat, and bronchial tubes.

Nitrogen oxide (NOx) gas is released through a reaction of nitrogen and oxygen promoted by high heat and/or UV radiation. It is severely irritating to the mucous membranes and the eyes. High concentrations may produce coughing and chest pain. Accumulation of fluid in the lungs can occur several hours after exposure and may be fatal.

Ozone gas is formed by the reaction of oxygen in air with the ultraviolet radiation from the welding arc. It may be a problem during gas-shielded metal arc welding in confined areas with poor ventilation. Overexposure can result in an accumulation of fluid in the lungs (pulmonary edema) which may be fatal.

Phosgene gas is formed by the heating of chlorinated hydrocarbon degreasing agents. It is a severe lung irritant and overexposure may cause excess fluid in the lungs. Death may result from cardiac or respiratory arrest. The onset of symptoms may be delayed for up to 72 hours.

Phosphine or hydrogen phosphide is produced when steel with a phosphate rustproofing coating is welded. High concentrations irritate eyes, nose, and skin.

Asphyxiants are chemicals which interfere with the transfer of oxygen to the tissues. The exposed individual suffocates because the bloodstream cannot supply enough oxygen for life. There are two main classes of asphyxiants — simple and chemical.

Simple asphyxiants displace oxygen in air, thereby leaving little or none for breathing. In welding, simple asphyxiants include commonly used fuel and shielding gases such as acetylene, hydrogen, propane, argon, helium, and carbon dioxide. When the normal oxygen level of 21% drops to 16%, breathing as well as other problems begin, such as

lightheadedness, buzzing in the ears, and rapid heartbeat.

Chemical asphyxiants interfere with the body's ability to transport or use oxygen. Chemical asphyxiants can be produced by the flame-cutting of metal surfaces coated, for instance, with rust inhibitors. Hydrogen cyanide, hydrogen sulphide, and carbon monoxide are examples of chemical asphyxiants — all highly toxic.

Dusts

Dusts are fine particles of a solid which can remain suspended in air and are less than 10 micrometres in size. This means they can reach the lungs. Dusts may be produced by fluxes and rod coatings which release phosphates, silicates, and silica. The most hazardous of these is silica which can produce silicosis — a disease of the lung which causes shortness of breath.

BIOLOGICAL HAZARDS

Biological hazards are a relatively minor concern for construction welders. However, exposure to bacteria may occur in sewer work, while air handling systems contaminated by bacteria and fungi can cause legionnaires' disease and other conditions. A fungus that grows on bird or bat droppings is responsible for a disease called histoplasmosis, producing flu-like symptoms. Contact may occur where buildings contaminated with droppings are being renovated or demolished.

Fires/Explosions

There is always a threat of fire with welding. Fires may result from chemicals reacting with one another to form explosive or flammable mixtures. Many chemicals by themselves have low ignition points and are subject to burning or exploding if exposed to the heat, sparks, slag, or flame common in welding. Even sparks from cutting and grinding may be hot enough to cause a fire.

In welding, oxygen and acetylene present the most common hazards of fire and explosion.

Pure oxygen will not burn or explode but supports the combustion of other materials, causing them to burn much more rapidly than they would in air.

Never use oxygen to blow dust off your clothing. Oxygen will form an explosive mixture with acetylene, hydrogen, and other combustible gases.

Acetylene cylinders are filled with a porous material impregnated with acetone, the solvent for acetylene. Because acetylene is highly soluble in acetone at cylinder pressure, large quantities can be stored in comparatively small cylinders at relatively low pressures.

Preventive Measures

Welding hazards must be recognized, evaluated, and controlled to prevent injury to personnel and damage to property.

The WHMIS chapter in this manual explains the information on hazardous materials that can be provided by WHMIS symbols, labels, and material safety data sheets.

Once a welding hazard has been identified, controls can be implemented at its source, along its path, or at the worker.

EXPOSURE FACTORS

Types and effects of airborne contaminants produced by welding depend on the working environment, the kind of welding being done, the material being welded, and the welder's posture and welding technique.

The **environment** for welding is a very important factor in the degree of exposure to fumes, vapours, and gases. Welding is best done outside or in open areas with moderate air movement. Air movement is necessary to dissipate fumes before they reach the welder. Enclosed areas with little ventilation can lead to very high exposure levels because the contaminant is not dispersed. In confined spaces, fume, vapour, and gas levels that are dangerous to life and health may result. Welding may also use up the oxygen in a confined space, causing the welder to lose consciousness or even die.

The **base metal** to be welded is an important factor in the production of fumes, vapours, and gases. The base metal will vaporize and contribute to the fume.

Coatings such as rust inhibitors have been known to cause increased fume levels which may contain toxic metals. All paints and coatings should be removed from areas to be welded as they can contribute to the amount and toxicity of the welding fume.

Welding rod is responsible for up to 95% of the fume. Rods with the fewest toxic substances can't always be used because the chemistry of the rod must closely match that of the base metal.

Shielding gas used during SMAW can effect the contaminants produced. Using a mixture of argon and carbon dioxide instead of straight carbon dioxide has been found to reduce fume generation by up to 25%. Nitric oxide in the shielding gas for aluminum during GMAW has been found to reduce ozone levels.

Welding process variables can have a big effect on the fume levels produced. Generally, fume concentrations increase with higher current, larger rods, and longer arc length. Arc length should be kept as short as possible while still producing good welds. Polarity is also a factor. Welding with reversed polarity (work piece negative) will result in higher fumes than welding with straight polarity (work piece positive).

The welder's **posture and technique** are crucial factors in influencing exposure. Studies have shown that different welders performing the exact same task can have radically different exposures. Welders who bend over close to the welding location, those who position themselves in the smoke plume, and those who use a longer arc than required will have a much greater exposure. The welder should try to take advantage of existing ventilation (cross drafts, natural, or mechanical) to direct the plume away from the breathing zone.

VENTILATION

Ventilation is required for all cutting, welding, and brazing. Adequate ventilation is defined as the use of air movement to

- reduce concentrations of airborne contaminants below the acceptable limits in the worker's breathing zone and the work area
- prevent the accumulation of combustible gases and

vapours, and

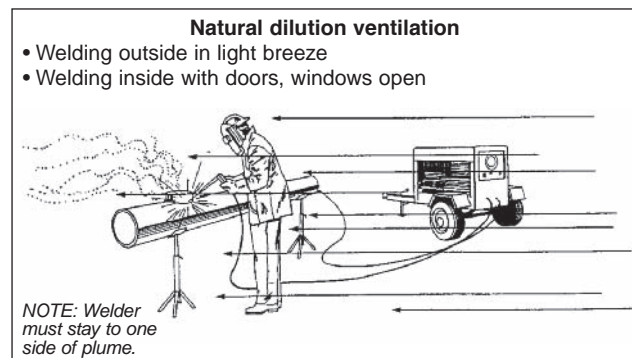
- prevent oxygen-deficient or oxygen-enriched atmospheres.

You need to take special steps to provide ventilation

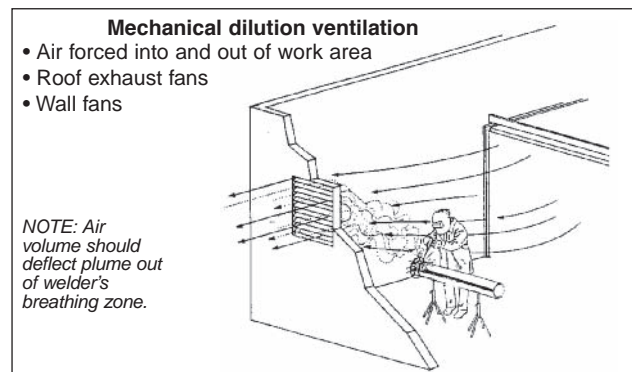
- in a space of less than 283 cubic metres per welder
- in a room with a ceiling of less than 4.9 metres
- in confined spaces or where the area contains partitions or other structures which significantly obstruct cross-ventilation.

Natural dilution ventilation — welding outside in a light breeze or inside with doors and windows open provides large volumes of fresh air which should disperse airborne contaminants sufficiently in most cases. However, it is important for the welder to stay to one side of the plume.

Natural dilution ventilation alone should not be used for welding, cutting, and allied processes in confined spaces or spaces containing structural barriers that restrict natural air movement.



Mechanical dilution ventilation is common in most welding shops. Fans such as roof exhaust fans and wall fans force outside air into and out of the building. General mechanical ventilation in most cases will deflect the plume out of the welder's breathing zone. Welders need different amounts of fresh-air ventilation depending on the specific task and the size of rod they're using. For air volume recommendations, see the American Conference of Governmental Industrial Hygienists' *Industrial Ventilation: A manual of recommended practice*.



Local exhaust ventilation consists of an exhaust fan, air cleaner, and ducted system dedicated to removing airborne contaminants at the source and exhausting them outdoors. Local exhaust ventilation is preferred over dilution ventilation because it is better able to prevent

airborne contaminants from entering the welder's breathing zone.

Local exhaust ventilation is recommended for welding where toxic airborne contaminants are produced and/or where a high rate of fume is produced — for instance, during GMAW in confined areas with little ventilation where the shielding gases can build up to toxic levels.

There are three types of local exhaust ventilation systems for welding:

- 1) portable fume extractor with flexible ducting (Figure 20.6)
- 2) fume extraction gun (Figure 20.7)
- 3) welding bench with portable or fixed hood (Figure 20.8).

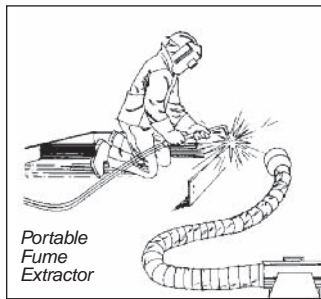


Figure 20.6

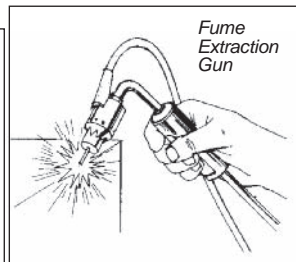


Figure 20.7

Local Exhaust Systems

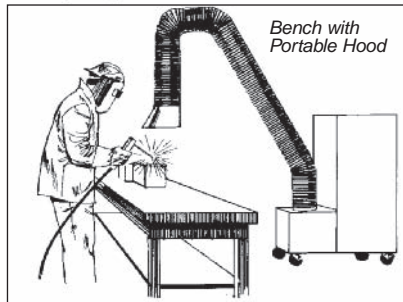


Figure 20.8

The effectiveness of local exhaust ventilation depends on the distance of the hood from the source, air velocity, and hood placement. Hoods should be located close to the source of airborne contaminants. The hood is placed above and to the side of the arc to capture airborne contaminants.

Warning: In all processes that use shielding gas, air velocities in excess of 30 metres/minute may strip away shielding gas.

Ventilation Requirements

There are two methods for determining ventilation requirements.

One uses air sampling to measure the welder's exposure to airborne contaminants and to determine the effectiveness of the ventilation provided. Monitoring is not well suited to construction because site conditions are constantly changing.

The other method uses tables to select the type of ventilation according to the process, materials, production level, and degree of confinement used in the welding operation.

Ventilation guidelines for different welding processes are spelled out in Canadian Standards Association standard CAN/CSA-W117.2 *Safety in Welding, Cutting and Allied Processes*, copyright CSA.

Other Controls

An isolation chamber is a metal box with built-in sleeves and gloves. The work is welded inside the box and viewed through a window. This method is used to weld metals that produce extremely toxic fumes. The fumes are extracted from the isolation chamber and ducted outdoors.

Respiratory protection

will not be required for most welding operations if proper ventilation is provided. However, when ventilation or other measures are not adequate, or when the welding process creates toxic fumes (as with stainless steel and beryllium), respiratory protection must be worn.

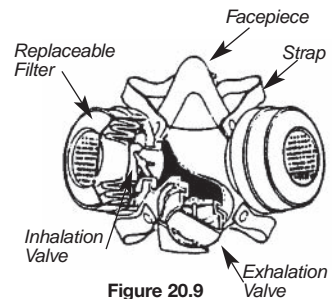


Figure 20.9

Select respiratory protection based on estimated exposure and the toxicity of the materials. Disposable fume respirators are adequate for low fume levels and relatively non-toxic fumes. For higher exposures or for work involving toxic fumes, a half-mask respirator with cartridges suitable for welding fume should be used (Figure 20.9).

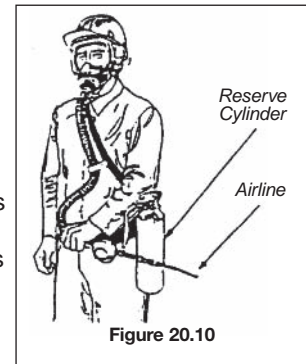


Figure 20.10

In areas where fume or gas concentrations may be immediately dangerous to life and health, a self-contained breathing apparatus (SCBA) or a supplied-air respirator with a reserve cylinder should be used (Figure 20.10). Use only supplied air or self-contained respirators in areas where gases may build up or where there can be a reduction in oxygen.

A welder required to wear a respirator must be instructed in its proper fitting, use, and maintenance. For more information, refer to the Respiratory Protection chapter of this manual.

FIRE PREVENTION

Sparks and slag from cutting, grinding, and welding can travel great distances and disappear through cracks in walls and floors or into ducts. They may contact flammable materials or electrical equipment. Fires have started in smoldering materials that went undetected for several hours after work was done.

Take the following steps to prevent fires and explosions.

- Obtain a hot work permit through the safety officer if required.
- Keep welding area free of flammable and explosive material.

- Use a flammable gas and oxygen detector to determine whether a hazardous atmosphere exists.
- Provide fire barriers such as metal sheets or fire blankets and fill cracks or crevices in floors to prevent sparks and slag from passing through.
- Provide fire extinguishers suitable for potential types of fire. Know where the extinguishers are and how to use them.
- Provide a firewatch where necessary — a worker to watch for fires as the welder works and for at least thirty minutes afterward. The person must be fully trained in the location of fire alarms and the use of fire-fighting equipment. Some situations may require more than one firewatch, such as on both sides of a wall or on more than one floor.

Cutting torches should be equipped with reverse flow check valves and flame arrestors to prevent flashback and explosion (Figure 20.11). These valves must be installed according to the manufacturer's instructions.

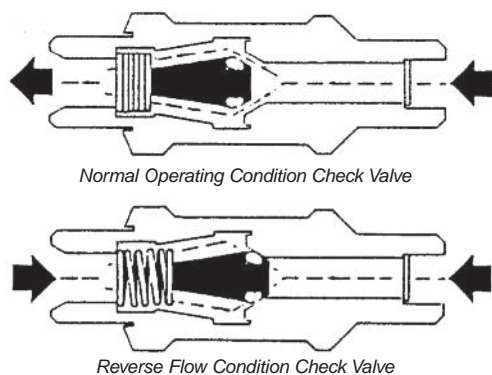


Figure 20.11

Drums, tanks, and closed containers that have held flammable or combustible materials should be thoroughly cleaned before welding or cutting. As an added precaution, purge with an inert gas such as nitrogen or carbon dioxide and fill with water to within an inch or two of the place to be welded or cut and vent to atmosphere (Figure 20.12).

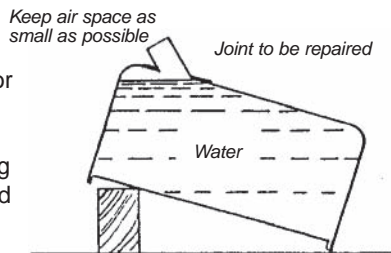


Figure 20.12

Many containers that have held flammable or combustible materials present special problems. Consult the manufacturer or the product MSDS for detailed information.

Arc Welding and Cutting

EQUIPMENT

Only use manual electrode holders that are specifically designed for arc welding and cutting and can safely handle the maximum rated current capacity required by the electrodes.

Any current-carrying parts passing through the portion of the holder in the welder or cutter's hand, and the outer

surfaces of the jaws of the holder, should be fully insulated against the maximum voltage encountered to ground.

Arc welding and cutting cables should be completely insulated, flexible, and capable of handling the maximum current requirements of the work as well as the duty cycle under which the welder or cutter is working.

Avoid repairing or splicing cable within 10 feet of the cable end to which the electrode holder is connected. If necessary, use standard insulated connectors or splices which have the same insulating qualities as the cable being used. Connections made with cable lugs must be securely fastened together to give good electrical contact. The exposed parts of the lugs must be completely insulated. Do not use cables with cracked or damaged insulation, or exposed conductors or end connectors.

A welding cable should have a safe current carrying capacity equal to or exceeding the maximum capacity of the welding or cutting machine.

Warning: Never use the following as part of the current path:

- cranes
- hoists
- chains
- wire ropes
- elevator structures
- pipelines containing gases or flammable liquids
- conduits containing electrical circuits.

The work lead, often incorrectly referred to as the ground lead, should be connected as close as possible to the location being welded to ensure that the current returns directly to the source through the work lead.

A structure employed as a work lead must have suitable electrical contact at all joints. Inspect the structure periodically to ensure that it is still safe. Never use any structure as a circuit when it generates arc, sparks, or heat at any point.

The frames on all arc welding and cutting machines must be grounded according to the CSA standard or the regulatory authority. Inspect all ground connections to ensure that they are mechanically sound and electrically adequate for the required current.

PROCEDURES

- When electrode holders are to be left unattended, remove electrode and place holder so it will not make contact with other workers or conducting objects.
- Never change electrodes with bare hands or with wet gloves.
- Do not dip hot electrode holders in water to cool them off.
- Keep cables dry and free of grease to prevent premature breakdown of insulation.
- Cables that must be laid on the floor or ground should be protected from damage and entanglement.
- Keep welding cables away from power supply cables and high tension wires.
- Never coil or loop welding cables around any part of your body.
- Do not weld with cables that are coiled up or on spools. Unwind and lay cables out when in use.

- Before moving an arc welding or cutting machine, or when leaving machine unattended, turn the power supply OFF.
- Report any faulty or defective equipment to your supervisor.
- Read and follow the equipment manufacturer's instructions carefully.
- Prevent shock by using well-insulated electrode holders and cables, dry clothing and gloves, rubber-soled safety boots, and insulating material (such as a board) if working on metal.
- All arc welding and cutting operations should be shielded by non-combustible or flame-proof screens to protect other workers from direct rays of the arc.
- Keep chlorinated solvents shielded from the exposed arc or at least 200 feet away. Surfaces prepared with chlorinated solvents must be thoroughly dry before being welded. This is especially important when using gas-shielded metal-arc welding, since it produces high levels of ultraviolet radiation.
- Check for the flammability and toxicity of any preservative coating before welding, cutting, or heating. Highly flammable coatings should be stripped from the area to be welded. In enclosed spaces, toxic preservative coatings should be stripped several inches back from the area of heat application or the welder should be protected by an airline respirator. In the open air, a suitable cartridge respirator should be used. Generally, with any preservative coating, check the manufacturer's MSDS for specific details regarding toxicity and personal protection required.
- Shut off the power supply before connecting the welding machine to the building's electrical power.

Oxyacetylene Welding and Cutting

HANDLING CYLINDERS

- Do not accept or use any compressed gas cylinder which does not have proper identification of its contents.
- Transport cylinders securely on a hand truck whenever possible. Never drag them.
- Protect cylinders and any related piping and fittings against damage.
- Do not use slings or magnets for hoisting cylinders. Use a suitable cradle or platform (Figure 20.13)
- Never drop cylinders or let them strike each other violently.
- Chalk EMPTY or MT on cylinders that are empty. Close valves and replace protective caps.
- Secure transported cylinders to prevent movement or upset.
- Always regard cylinders as full and handle accordingly.
- For answers about handling procedures, consult the manufacturer, supplier, or the MSDS.

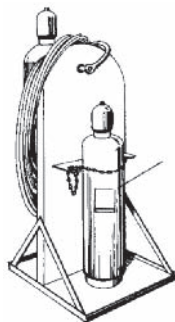


Figure 20.13

STORING CYLINDERS

- Store cylinders upright in a safe, dry, well-ventilated location maintained specifically for this purpose.

- Never store flammable and combustible materials such as oil and gasoline in the same area.
- Do not store cylinders near elevators, walkways, stairwells, exits, or in places where they may be damaged or knocked over.
- Do not store oxygen cylinders within 20 feet of cylinders

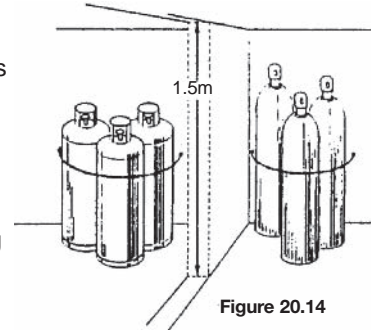


Figure 20.14

- containing flammable gases unless they are separated by a partition at least 5 feet high and having a fire-resistance rating of at least 30 minutes (Figure 20.14).
- Store empty and full cylinders separately.
- Prohibit smoking in the storage area.

USING CYLINDERS

- Use oxygen and acetylene cylinders in a proper buggy equipped with a fire extinguisher (Figure 20.15). Secure cylinders upright.
- Keep the cylinder valve cap in place when the cylinder is not in use.
- Do not force connections on cylinder threads that do not fit.
- Open cylinder valves slowly. Only use the handwheel, spindle key, or special wrench provided by the supplier.
- Always use a pressure-reducing regulator with compressed gases. For more information see the box below.
- Before connecting a regulator to a cylinder, crack the cylinder valve slightly to remove any debris or dust that may be lodged in the opening. Stand to one side of the opening and make sure the opening is not pointed toward anyone else, other welding operations, or sparks or open flame.
- Open the fuel gas cylinder valve not more than 1½ turns unless marked back-seated.
- Do not use acetylene pressure greater than 15 psig.
- Never allow sparks, molten metal, electric current, or excessive heat to come in contact with cylinders.
- Never use oil or grease as a lubricant on the valves or attachments of oxygen cylinders. Do not handle with oily hands, gloves, or clothing. The combination of oxygen and oil or grease can be highly combustible.
- Never bring cylinders into unventilated rooms or enclosed areas.
- Do not use oxygen in place of compressed air for pneumatic tools.
- Release pressure from the regulator before removing it from the cylinder valve.

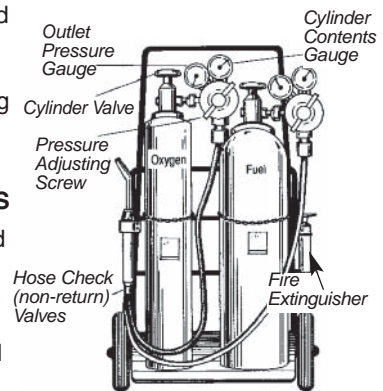


Figure 20.15

- When gas runs out, extinguish the flame and connect the hose to the new cylinder. Purge the line before re-igniting the torch.
- When work is finished, purge regulators, then turn them off. Use a proper handle or wrench to turn off cylinders.

Pressure Regulators

Pressure regulators must be used on both oxygen and fuel gas cylinders to maintain a uniform and controlled supply of gas to the torch.

The oxygen regulator should be designed with a safety relief valve so that, should the diaphragm rupture, pressure from the cylinder will be released safely and the regulator will not explode.

Each regulator (both oxygen and fuel gas) should be equipped with a high-pressure contents gauge and working pressure gauge. Always stand to one side of regulator gauge faces when opening the cylinder valves.

To prevent regulators from being installed on the wrong cylinders, oxygen cylinders and regulators have *right-hand* threads while most fuel gas cylinders and regulators have *left-hand* threads.

Internal and external threads and different diameters also help to prevent wrong connections.

Hoses and hose connections for oxygen and acetylene should be different colours. Red is generally used to identify the fuel gas and green the oxygen. The acetylene union nut has a groove cut around the centre to indicate left-hand thread.

- Protect hoses from traffic, flying sparks, slag, and other damage. Avoid kinks and tangles.
- Repair leaks properly and immediately. Test for leaks by immersing hose in water.
- Use backflow check valves and flame arrestors according to the manufacturer's instructions (Figure 20.11).
- Do not use a hose which has been subject to flashback or which shows evidence of wear or damage without proper and thorough testing.

Backfires occur when the flame burns back into the torch tip, usually accompanied by a loud popping sound. Backfires usually are caused by touching the tip against the work or by using pressures that are too low.

Flashback is much more serious. The flame burns back inside the torch itself with a squealing or hissing sound. If this happens, follow the torch manufacturer's instructions to extinguish the torch in proper sequence.

Many different makes, models, and designs of torches are available. There is no single procedure or sequence to follow in igniting, adjusting, and extinguishing the torch flame. Always follow the manufacturer's instructions.

Oxyacetylene Summary

Startup

- Keep cylinders away from sources of heat or damage and secure them upright.
- Stand to one side and slightly crack cylinder valves to blow out dust.

- Attach regulators to respective cylinders. Tighten nuts with a proper wrench.
- Release pressure adjusting screws on regulators.
- Connect green hose to oxygen regulator and red hose to fuel gas regulator.
- Connect hoses to the torch — green to oxygen inlet and red to fuel gas inlet.
- Connect mixer and welding tip assembly to torch handle.
- Open oxygen cylinder valve slowly and fully.
- Open fuel gas cylinder $\frac{3}{4}$ to $1\frac{1}{2}$ turns.
- Open oxygen torch valve. Turn oxygen regulator pressure adjusting screw to desired pressure. Continue oxygen purge for about 10 seconds for each 100 feet of hose. Close oxygen torch valve.
- Open fuel gas torch valve. Turn fuel gas regulator pressure adjusting screw to desired pressure and purge for about 10 seconds for each 100 feet of hose. Close fuel gas torch valve.
- To light torch, follow the manufacturer's instructions. **DO NOT USE MATCHES.**
- Adjust to desired flame.

Closedown

- Close torch valves according to the manufacturer's instructions.
- Close fuel gas cylinder valve.
- Close oxygen cylinder valve.
- Drain fuel gas cylinder line by opening torch fuel gas valve briefly. Close valve. Drain oxygen line in the same way.
- Re-open both torch valves.
- Release pressure adjusting screws on both regulators.

Regulators and torches can now be disconnected.

SILVER SOLDER BRAZING

Silver solder brazing is used for joining metals and steel and dissimilar metal combinations where it is necessary to perform the joining of these metals at low temperatures. Applications include medical and laboratory systems, refrigeration, aerospace, and electronic equipment. In brazing, the major hazards are heat, chemicals, and fumes.

Fumes generated during brazing can be a serious hazard. Brazing fluxes generate fluoride fumes when heated. Cadmium in silver brazing alloys vaporizes when overheated and produces cadmium oxide, a highly toxic substance. Cadmium oxide fumes inhaled into the respiratory tract can cause pulmonary distress, shortness of breath, and in cases of severe exposure may cause death.

The most serious cause of cadmium oxide fumes is overheating the silver brazing filler metal. Care must be taken to control the temperature of the silver brazing operation. The torch flame should never be applied directly to the silver brazing filler rod. The heat of the base metal should be used to melt and flow the brazing filler metal.

Cadmium-plated parts can be an even more hazardous source of cadmium fumes, since in brazing these parts the torch flame is applied directly to the base metal. Cadmium plating should be removed before heating or brazing. When in doubt about a base metal, check with the supplier of the part.

Safe Silver Solder Brazing

- Do not heat or braze on cadmium-plated parts.
- Read warning labels on filler metals and fluxes and follow instructions carefully.
- Work in a well-ventilated area or use a supplied-air respirator.
- Apply heat directly to the base metal—not to the brazing filler metal.
- Do not overheat either the base metal or the brazing filler metal.
- Wash hands thoroughly after handling brazing fluxes and filler metals.

Confined Spaces

Welding in enclosed or confined areas creates additional hazards for the welder. The employer must have a written rescue procedure for confined spaces.

In addition to the procedures outlined in the chapter on confined spaces in this manual, take the following precautions.

- Inspect all electrical cables and connections that will be taken into the confined space.
- Perform leak tests on gas hoses and connections to eliminate the risk of introducing gases into the confined space.
- Check for live electrical systems and exposed conductors.
- Use inspection ports, dipsticks, and the knowledge of plant personnel to evaluate hazards from any liquids, solids, sludge, or scale left in the space.
- Isolate the space from any hydraulic, pneumatic, electrical, and steam systems which may introduce hazards into the confined area. Use isolation methods such as blanks, blinds, bleeding, chains, locks, and blocking of stored energy. Tag isolated equipment.
- A competent person must test and evaluate the atmosphere before workers enter a confined space, and at all times during work there. A hazardous atmosphere may already exist or gases and vapours may accumulate from cutting or welding. Oxygen content may become enriched or depleted.
- Ventilate space with clean air before entry and maintain ventilation as long as necessary to prevent the accumulation of hazardous gases, fumes, and vapours.
- Different gases have different weights and may accumulate at floor, ceiling, or in between. Air monitoring should be done throughout the confined space.
- Keep compressed gas cylinders and welding power sources outside the confined space.
- Where practical, ignite and adjust flame for oxy-fuel applications outside the space, then pass the torch inside. Similarly, pass the torch outside the space, then extinguish it.
- When leaving a confined space, remove the torch and hoses and shut off gas supply.
- If adequate ventilation cannot be maintained, use a suitable supplied-air respirator.

It is the responsibility of the employer to have a written **emergency rescue plan** and communicate the plan to all involved. Each person should know what to do to and how to

do it quickly. See the Confined Spaces chapter in this manual.

Personal Protective Equipment

In addition to the protective equipment required for all construction workers (see chapters on personal protective equipment in this manual), welders should wear flame-proof gauntlet gloves, aprons, leggings, shoulder and arm covers, skull caps, and ear protection.

Clothing should be made of non-synthetic materials such as wool. Woollen clothing is preferable to cotton because it is less likely to ignite. Keep sleeves rolled down and collars buttoned up. Wear shirts with flaps over pockets and pants with no cuffs. Remove rings, watches, and other jewelry. Never carry matches or lighters in pockets. Clothing should be free from oil and grease.

Wear high-cut CSA grade 1 footwear laced to the top to keep out sparks and slag.

Protective screens or barriers should be erected to protect people from arc flash, radiation, or spatter. Barriers should be non-reflective and allow air circulation at floor and ceiling levels. Where barriers are not feasible or effective, workers near the welding area should wear proper eye protection and any other equipment required.

Signs should be posted to warn others of welding hazards.

EYE AND FACE PROTECTION

Welding helmets provide radiation, thermal, electrical, and impact protection for face, neck, forehead, ears, and eyes. Two types are available — the stationary plate helmet and the lift-front or flip-up plate helmet.

The lift-front type should have a fixed impact-resistant safety lens or plate on the inside of the frame next to the eyes to protect the welder against flying particles when the front is lifted. All combination lenses should have a clear impact-resistant safety lens or plate next to the eyes.

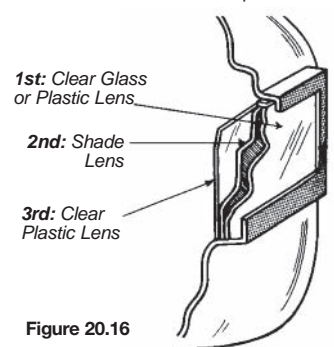
There are also special models incorporating earmuff sound arrestors and air purification systems. Special prescription lens plates manufactured to fixed powers are available for workers requiring corrective lenses.

The typical lens assembly for arc welding is shown in Figure 20.16.

The filtered or shaded plate is the radiation barrier. It is necessary to use a filter plate of the proper lens shade to act as a barrier to the harmful light rays and to reduce them to a safe intensity. Guidelines for selection are shown in Figure 20.17.

In addition to common green filters, many special filters are available. Some improve visibility by reducing yellow or red flare. Others make the

The arc welding lens assembly consists of 3 parts. The outside lens is clear plastic or tempered glass. It protects the shade lens from damage. The centre lens is a shade lens that filters out the harmful light. The inner lens is clear and must be plastic.



colour judgment of temperature easier. Some have a special gold coating on the filter lens to provide additional protection by reflecting radiation.

Welding hand shields are designed to provide radiation and impact protection for the eyes and face. They are similar to welding helmets except that there are no lift-front models.

Spectacles with full side shields designed to protect against UV radiation and flying objects and suitable filter lenses should always be worn in conjunction with full welding helmets or welding hand shields.

Where only moderate reduction of visible light is required (for instance, gas welding) use eyecup or cover goggles with filter lenses for radiation protection. Goggles should have vents to minimize fogging and baffles to prevent leakage of radiation into the eye cup.

Welders should not wear contact lenses because airborne dust and dirt may cause excessive irritation of the eyes under the lenses.

HEARING PROTECTION

See the Hearing Protection chapter in this manual. Welders may find that ear muffs are cumbersome and interfere with the welding helmet. Ear plugs may be a better choice but must be properly inserted to ensure protection.

Welders should have their hearing checked every year or so. A simple test can be arranged through your doctor. Once hearing is damaged, the loss is likely permanent. Checkups can detect any early losses and help you to save your remaining hearing.

Continue on next page for “Radiographic and X-Ray Testing.”

Lens Shade Selection Guide for Welding

Shade numbers are given as a guide only and may be varied to suit individual needs.

Operation	Electrode Size	Arc Current	Minimum Protective Shade	Suggested ¹ Shade No. (Comfort)
	mm (32nd in.)	(Amperes)		
Shielded Metal Arc Welding (SMAW)	less than 2.5 (3)	less than 60	7	–
	2.5-4 (3-5)	60-160	8	10
	4-6.4 (5-8)	>160-250	10	12
	more than 6.4 (8)	>250-550	11	14
Gas Metal Arc Welding and Flux Cored (GMAW)		less than 60	7	–
		60-160	10	11
		>160-250	10	12
		>250-500	10	14
Gas Tungsten Arc Welding (GTAW)		less than 50	8	10
		50-150	8	12
		>150-500	10	14
Air Carbon (light) Arc Cutting (heavy)		less than 500	10	12
		500-1000	11	14
Plasma Arc Welding (PAW)		less than 20	6	6 to 8
		20-100	8	10
		>100-400	10	12
		>400-800	11	14
Plasma Arc Cutting (PAC)				
	Light ²	less than 300	8	9
	Medium	300-400	9	12
	Heavy	>400-800	10	14
Torch Brazing (TB)		–	–	3 or 4
Torch Soldering (TS)		–	–	2
Carbon Arc Welding (CAW)		–	–	14
			Plate Thickness	
			mm	in.
Gas Welding (GW)				
	Light	under 3.2	under 1/8	4 or 5
	Medium	3.2 to 13	1/8 to 1/2	5 or 6
	Heavy	over 13	over 1/2	6 to 8
Oxygen Cutting (OC)				
	Light	under 25	under 1	3 or 4
	Medium	25 to 150	1 to 6	4 or 5
	Heavy	over 150	over 6	5 or 6

Figure 20.17

1. Shade numbers are given as a general rule. It is recommended to begin with a shade that is too dark to see the weld zone. Then one should go to a lighter shade which gives sufficient view of the weld zone without going below the minimum. In gas welding or oxygen cutting where the torch produces a high yellow light, it is desirable to use a filter lens that absorbs the yellow or sodium line in the visible light of the operation (spectrum).
2. These values apply where the actual arc is clearly seen. Experience has shown that light filters may be used when the arc is hidden by the workpiece.

Reproduced with the permission of the American Welding Society.

Radiographic and X-Ray Testing

Some construction trades will encounter situations in which welds, metals, or special coatings require on-site non-destructive testing.

Methods include

- 1) radiography using a radioactive source for general materials
- 2) x-rays for testing thicker sections.

Radiography is federally regulated across Canada by the Atomic Energy Control Board. Users must be licensed and operators must be trained according to a Canadian Government Standards Board (CGSB) program.

X-ray testing is provincially regulated—in Ontario by Regulation 632/86.

While many requirements apply to licensed users in both situations, this section will only cover the basic health and safety guidelines for field use.

RADIOGRAPHIC TESTING

Licensed users of radiographic testing systems are responsible for general safety in the field, transportation, emergency procedures, and record-keeping.

Radiographic testing must be carried out in the presence of persons certified to CGSB Standard 48GP4a. In general these people are employees of a recognized testing agency.

Radiographic materials and equipment must be kept locked up in shielded storage containers accessible only to certified personnel. The containers must be conspicuously marked and kept in an area not normally occupied by the workforce. There may be other special requirements which apply, depending on the strength of the radioactive source and the location.

Radiographic cameras in the field must be used in conjunction with pocket dosimeters, survey meters, directional shields, barrier ropes, radiographic warning signs, and an emergency source container.

General Safety Precautions

- Radiographic testing should be conducted, whenever possible, on an off-shift with as few workers as possible in the work area. The radiographic source should be no stronger than is required for the job. Determining the strength of the source is not generally the responsibility of construction site personnel.
- Equipment should be checked before use. The regulation includes a list of items to be checked, but doing so is not usually the responsibility of site personnel.
- After taking tests where the camera will be moved, the area should be checked using a survey meter.
- Licensed users are required to keep records regarding the use of sources, including dates, times, locations, and other details. These records must be made available to inspectors from the Atomic Energy Control Board. Users are also responsible for advising the local fire department when radioactive material will be in a municipality for longer than 24 hours.

Specific requirements for radiographic camera users are the responsibility of the certified persons operating the equipment.

- The survey meter must be checked to ensure that it is working and calibrated properly.
- Barrier ropes should be set up around the area where testing will be carried out unless this area is isolated and access can be controlled. Barriers must be set up according to the strength of the source.
- Warning signs must be posted along the barriers.
- A patrol must be provided to ensure that no unauthorized persons enter the testing area.
- Before the camera shutter is opened and testing is conducted, the area must be properly shielded.
- Personnel working within the testing area should carry personal dosimeters. Dosimeters may also be advisable for workers in the immediate vicinity outside the barriers.

X-RAY TESTING

Certain basic health and safety precautions are required for the x-ray testing of welds and metals.

- There must be suitable means to prevent unauthorized persons from activating the equipment.
- There must be some device to indicate when the x-ray tube is energized.
- The housing must adequately shield the equipment operator.
- Employers using X-ray equipment must advise the Ministry of Labour that they have such equipment.
- Employers must designate certain persons to be in charge of x-ray equipment who are trained and competent to do so, and must give the Ministry of Labour the names of these designated persons.

Measures and procedures at the x-ray testing site are similar to those required for radiographic testing. The following are the employer's responsibilities.

- Test during off-shifts.
- Cordon off the test area if it cannot be isolated or if entry cannot be controlled.
- Post warning signs along the barrier or at the entrance to the room where testing is taking place.
- Have a patrol to prevent unauthorized entry.
- Install shielding as required before any equipment is activated.
- Ensure that employees in the controlled area wear personal dosimeters.
- Keep dosimeter records.
- Keep at least one radiation survey meter of a suitable type with each portable x-ray machine and calibrate it at least once each year.

Training

Welders, fitters, and welding supervisors should be trained in both the technical and safety aspects of their work. Health and safety training should include but not be limited to the following:

- hazard identification
- safe welding, brazing, and cutting practices
- fire and safety precautions
- control methods for welding hazards

- use, maintenance, and limitations of personal protective equipment.

The effectiveness of health and safety training should be periodically evaluated through

- a workplace inspection to ensure that safe working procedures, equipment, and conditions are implemented.
- air monitoring of common contaminants to determine the effectiveness of controls and compliance with acceptable limits.
- an assessment of control performance (for instance, testing of the ventilation system)
- review of lost-time-injuries
- discussion of the program with the health and safety committee or representative(s).

Any corrective actions necessary should be taken immediately.

42 FORMWORK

Glossary

The following definitions are used in the forming industry. Some terms may be used by other trades as well, but their meanings may be different from these depending upon the application.

Falsework, in relation to a form or structure, means the structural supports and bracing used to support all or part of the form or structure.

Flying formwork is a designed system which can be hoisted between levels as a unit.

Forms are the moulds into which concrete or another material is poured.

Formwork is a system of forms connected together.

Gangforms are large panels designed to be hoisted as a unit, and to be erected, stripped, and re-used.

Knock-down forms are traditional formwork supported by falsework and shoring, assembled from bulk materials, used once, and then dismantled.

Panels are sections of form intended to be connected together.

Sheathing is the material directly supported by wales, and against which concrete is to be placed.

Specialty formwork is designed specifically for a particular structure or placing technique.

Struts are vertical members of shoring that directly resist pressure from wales.

Wales are horizontal members of shoring that are placed against sheathing to directly resist pressure from the sheathing.

General

In most cases, the formwork required for concrete construction is built by carpenters. Shoring and bracing support the forms that contain the wet concrete. Formwork must also support the temporary weight of material such as bundles of reinforcing steel and live loads of workers and equipment.

There are three stages in formwork operations:

- assembly and erection
- concrete placement
- stripping and dismantling.

To be done safely, each of these jobs requires planning, knowledge, and skill from both supervisors and workers. Design and planning are a supervisory function that may also legally require a professional engineer's involvement. Small construction and renovation jobs, however, sometimes call for design on site by workers.

Where design drawings are provided, it is important to construct the formwork as designed. Any confusion regarding the design should be cleared up with the designer.

If site conditions require changes or the design does not seem to suit the situation, clarification should also be obtained from the designer. Formwork failures frequently

involve deviations from the original design that were done without consulting the designer. They may also involve human error. For these reasons, formwork and shoring must always be inspected before concrete is placed.

All large formwork installations in Ontario must be designed by a professional engineer. But there are always smaller jobs of moderate height or depth – basements, footings, stairs – that may include formwork designed and constructed on the site.

Every carpenter should therefore know the type of formwork needed and how to build, install, and dismantle it safely.

Formwork must always be constructed according to good, safe, and sound carpentry practice. There must be

- adequate braces and supports
- reliable bearing surfaces, especially where wood structures are involved
- adequate ties, bolts, or bracing to prevent movement or bulging.

Because wood is relatively soft, it will crush under heavy loads such as concrete when the bearing surface of joists on stringers, or studs on wales, is not adequate.

Crushing can be avoided by increasing the bearing area between members, using spreader washers (Figure 189), or increasing the number of joists or studs.

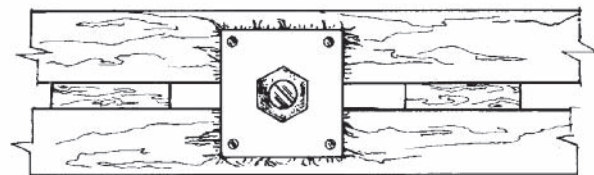


Figure 189
Spreader Washer on Wooden Wale System

Hazards

The following are the main hazard areas in formwork operations.

- **Falls** – They are the major hazard because they are **potentially fatal**. Cramped work areas, inadequate access, failure to install guardrails, failure to use fall-arrest systems, tools or material left underfoot, and surfaces slippery from form oil can all lead to falls. Ladders are also frequently involved in falls.

Workers must have fall protection whenever they are exposed to the risk of falling more than 3 metres, or falling from any height into dangerous machinery, substances, or objects such as rebar. In some circumstances, you must use fall protection when the height is 2.4 metres (8 ft.) or more. (See chapters on Guardrails and Personal Fall Protection.)

- **Materials handling** – **The activity most frequently connected with injury**. Improper or excessive materials handling can result in sprains, strains, and overexertion in shoulders, arms, and back, as well as bruises, abrasions, and crushed fingers.
- **Struck against** – Common because formwork operations are constantly changing and involve the movement of heavy, awkward, and pointed

components. Wales, beams, panels, snap-ties, nails, bolts, and rebar can cause punctures, cuts, contusions, and abrasions.

- **Struck by** – Another common cause of injury. Rebar, formwork panels, concrete buckets, and other material hoisted overhead can strike workers. Struck-by injuries can also be caused by hammers, pry bars, stakes, wedges, and material such as joists and panels during stripping.
- **Electrical contact** – Power tools, extension cords, and temporary supply and wiring systems, used under less-than-ideal conditions – mud, ground water, wet excavations, fresh concrete – can lead to ground faults, shortcircuits, and shock hazards. Ground fault circuit interrupters are legally required for portable tools used outdoors or in wet locations.
- **Collapses** – Even with advanced methods of design and installation, there is always the risk that formwork, slabs, wall forms, and other large components can come loose, slip out of place, or fall over, striking or crushing workers underneath.
- **Health hazards** – The spraying of form oils and curing compounds can irritate the lungs. Contact with these chemicals can irritate the skin, leading to redness, inflammation, or dermatitis. The same conditions can result from the abrasive/corrosive effect of skin contact with concrete or cement, especially when inadvertently left inside boots all day.
- **Environmental conditions** – Ice, snow, and rain create slippery conditions. Wind can be a major hazard. Handling sheets of plywood becomes more difficult, panels may require more bracing, and hoisting gets harder, especially with large panels or tables.
- **Dust and concrete** – Blowing dust and flying concrete particles during the chipping or cleaning of formwork can injure unprotected eyes.
- **Access equipment** – Access equipment such as ladders and scaffolds is involved not only in falls but in slips, trips, and other accidents. Hazards include ladders not tied off, workers carrying materials while climbing, ladders obstructed at top or bottom, scaffolds not completely decked in, and scaffolds erected or dismantled without fall protection.
- **Lighting** – Inadequate lighting can create or aggravate hazards when workers install or strip forms in dark areas or place concrete at night.

Injuries

Formwork hazards can lead to the injuries – and be prevented by the measures – described below.

- **Eye injuries** – These are quite prevalent in formwork operations. Most result from particles of wood or concrete that fall or are blown into the eye during chipping and cleaning. The injuries may not be severe but most can be prevented by wearing eye protection. It is strongly recommended that everyone on site wear eye protection at all times.
- **Cuts, scrapes, punctures** – The manhandling necessary to install and strip formwork can lead to cut hands, arms, and legs, as well as pinched or crushed

fingers. Gloves help to prevent injuries from rough or sharp edges on formwork components. But workers must also have the knowledge, skill, and physical ability necessary for safe materials handling. That means knowing your limitations and asking for help when needed. Formwork involves protruding objects such as nails, snap ties, conduit, and bolts that can give you cuts and punctures. Where possible, these objects should not be left sticking out or should be covered over.

- **Back injuries** – These injuries are frequently related to materials handling. The most important preventive measure is back care. Exercise programs, warm-ups before work, and knowing your limitations can help to prevent sprains and strains. Wherever necessary, get help or use dollies, carts, or other mechanical devices.
- **Ankle sprains and fractures** – Working in close quarters, stepping over debris and material, climbing into excavations, turning with awkward loads, jumping down from scaffolds or benches — these can lead to ankle and other foot or leg injuries. Prevention starts with proper housekeeping and materials handling.
- **Bruises and contusions** – Handling formwork under rushed, cramped, or slippery conditions or beyond your limitations can lead to bruises. Bruises and contusions also result from contact with protruding formwork components. More serious are contusions from falling formwork materials. Formwork must be braced to ensure stability, especially under windy conditions. Try to avoid areas where work such as hoisting or stripping is being done overhead.
- **Fall injuries** – All of the injuries above, and many others, can result from falls. Most falls are caused by missing or inadequate guardrails, failure to use fall-arrest equipment, failure to completely plank scaffolds and other work platforms, and standing or climbing on surfaces not meant to be used as such – the tops of wall forms or 2 x 4 wales, for example. Installing and stripping formwork often requires the use of a fall-arrest system.
Falls also result from holes left unguarded or uncovered in formwork. These should be covered up or fitted with guardrails as quickly as possible. Where this cannot be done, the area should be roped off and posted with warning signs to prevent unauthorized entry.

Planning

Planning is the first and most important step in reducing hazards and preventing injuries.

Because formwork operations must often be carried out in congested areas where other trades are also working, planning is essential in making the most of the time and space available to improve safety and efficiency.

Planning is a must for fall protection, work platforms, material staging areas, housekeeping, and material handling and movement.

Planning should take place at every level from manager through supervisor to worker. Planning labour, materials,

equipment, and work schedules to meet design requirements is the responsibility of management and supervision.

Workers must plan the details of their assigned tasks based on the most effective work methods and safety measures to follow in each case.

Design

Safety and economy are the main factors in design. Both have to be considered because adjustments in one affect the other.

For example, reducing the support structure for wall forms in expectation of reduced pouring rates should not be considered if the rate of pour is not going to be controlled on the job.

Fresh concrete exerts a pressure on formwork similar to liquids. However, concrete starts to set when poured so that if the pour rate is slow the maximum pressure can be reduced, since concrete at the bottom will be set before concrete at the top is poured. Similarly, if the forms are filled to the top immediately, they must be able to withstand the pressure of the full liquid head. Liquid concrete exerts a minimum pressure of 150 pounds/foot² times the height in feet.

Other factors determine how long concrete will remain liquid, such as temperature, slump, vibration, and admixtures. For example, concrete will set much more quickly in hot summer weather than in cold winter weather. As a result, the same form filled at the same pour rate may be subjected to greater pressure in winter than in summer.

Concrete pumping may cause additional pressure, as well as vibration, on forms and must be considered at the design stage. The action of the pump sends surges of pressure through the piping system which are often transmitted directly to the forms, especially for narrow walls or columns. Vibration may move the forms or loosen bracing, ties, or spreaders.

Pressure acts perpendicular to formwork surfaces (Figure 190). This causes an outward thrust for typical wall or column forms. However, it can also cause uplift for

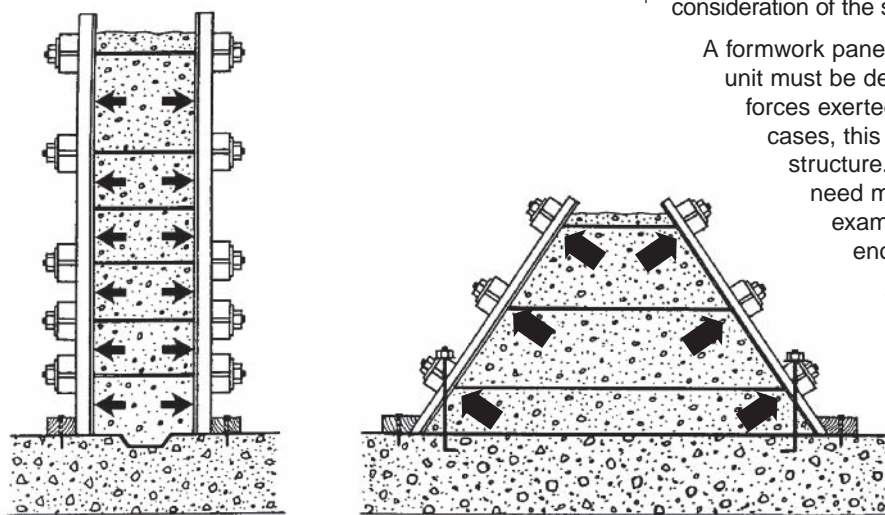


Figure 190 — Pressure of Concrete on Vertical and Battered Formwork
(Note expansion anchors holding down battered form.)

battered or sloping forms. These require hold-down anchors or tie-down braces. The anchors will prevent the forms from lifting up or floating on the concrete.

Consider using bracing systems and spreaders for wall forms. Concrete filling the bottom of the form may cause forces at the top to push the two sides together unless they are properly braced and/or separated with spreaders. Formwork has to be designed to resist such forces. During pouring, ensure that spreaders are not removed until concrete has reached at least two-thirds of the form height.

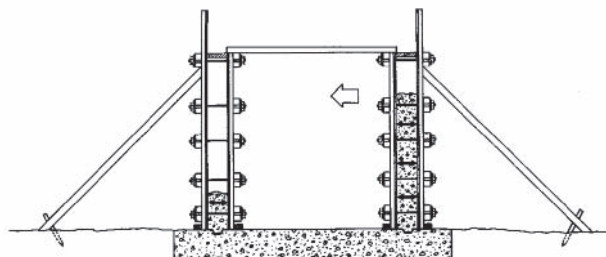


Figure 191

Open-cut tunnel formwork with bracing and spreaders on each side

Where box forms are used – for instance, on one-piece covers for open-cut tunnels – you must use bracing against the side thrusts caused by the uneven pouring rates of the walls. Resisting these forces requires that the system be tied together and securely braced (Figure 191).

Formwork should be designed and constructed with stripping and removing as well as pouring in mind. On wooden forms, crush plates or filler strips should be used at corners such as slab-and-column or slab-and-wall intersections (Figure 192). The plates or strips are easily removed with a wrecking bar and, once removed, make the stripping of adjacent panels much easier.

The strips should be big enough to leave space at the edges of the panels to accommodate wrecking bars.

When formwork has to be manhandled during assembly or dismantling, the design should ensure that the components are manageable. Formwork panels are not only heavy but awkward (Figure 193). Realistic design demands consideration of the size as well as the weight of panels.

A formwork panel or wall form to be lifted as a single unit must be designed to withstand the loads and forces exerted by hoisting (Figure 194). In most cases, this means designing a more substantial structure. Fastening components may also need more attention at the design stage. For example, simple nailing may not be enough to hold plywood sheets.

Special attention must also be applied to the design, construction, and use of pick points for hoisting. The strongbacks and wales must be securely attached to the formwork. The pick points must be located so that the panel hangs properly during installation, concrete placement, and removal.

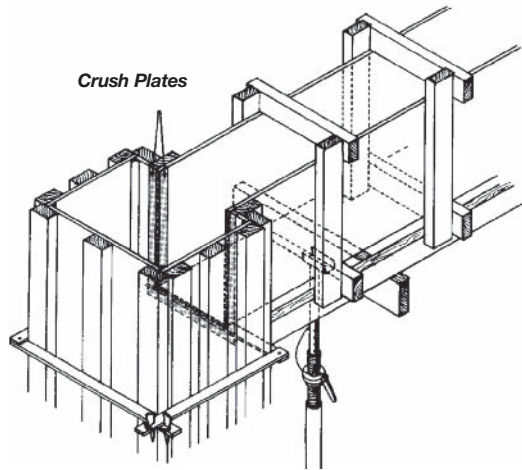


Figure 192 – Crush Plates

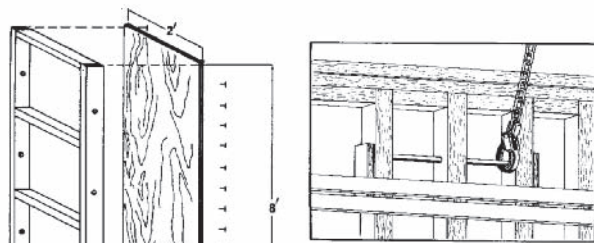


Figure 193 – Formwork Panel

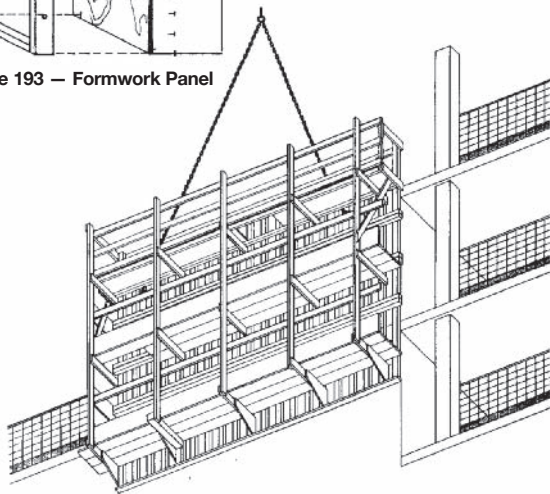


Figure 194 – Formwork Lifted as Single Unit

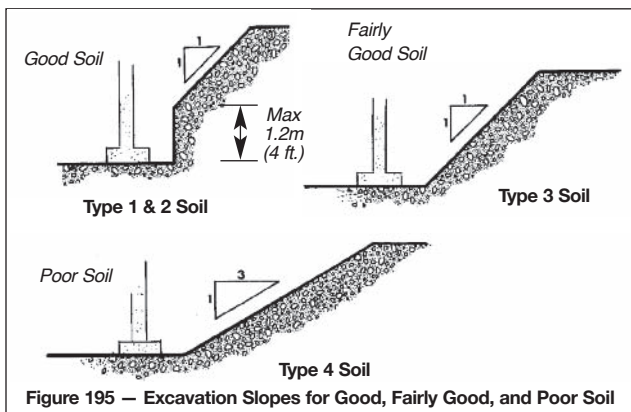


Figure 195 – Excavation Slopes for Good, Fairly Good, and Poor Soil

Types of Formwork

Below Grade

The first concern with formwork below grade is the stability of the excavation walls. Walls must be either shored or sloped according to soil type as defined by the Construction Regulation (O.Reg. 213/91). Figure 195 shows typical slopes.

In most cases the shoring must be designed by an engineer. Engineers may also specify slopes for excavations. In both instances the design drawings must be kept on the project.

Excavations should be kept essentially dry. Water should be pumped out. Mud should be cleared off and replaced by compacted granular material in work areas and on surfaces where concrete will be placed. Mud presents slipping hazards and can lead to inferior construction if not removed or replaced.

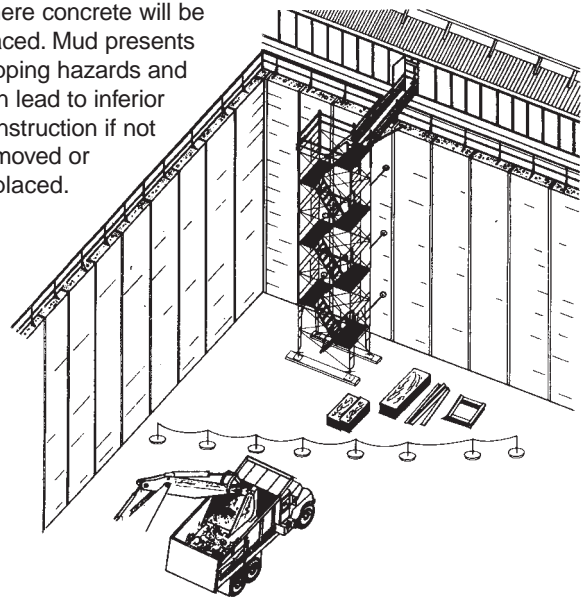


Figure 196
Formwork Roped-Off from Other Operations

Since mud has to be removed before concrete is placed, it might as well be removed before formwork is constructed, thereby reducing slipping hazards at both stages.

Water and mud also contribute to electrical hazards. Grounding and insulation must be effective and intact. Ground fault circuit interrupters (GFCIs) are required by law on all portable tools used outdoors or in wet locations.

Formwork for footings and grade walls frequently begins before excavation in the area is complete. Trucks and excavating equipment put workers on foot at the risk of being struck down or run over.

Wherever possible, formwork operations should be roped off from other work such as excavation or pile-driving (Figure 196). Separate access ramps for vehicles and workers are strongly recommended. Stairs are an even better alternative for personnel on foot.

Mud sills must be used to support any shoring or bracing that rests on soil in the excavation (Figure 197). The sill must bear on the soil throughout its length. Sills should not be used to bridge holes or irregular surfaces. To ensure uniform bearing, soil should be levelled before sills are set in position.

The soil must have the capacity to bear whatever loads are applied. This information may or may not be on the design drawings.

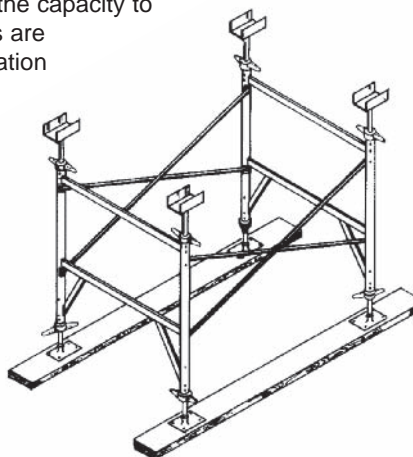


Figure 197
2" x 10" Mud Sills Under Shoring Frames
Good Soil Bearing Capacity – Moderate Load

In Situ Bearing Pressure for Dry Soil Conditions (Conservative Estimates)	
Silt and clay	1200 lbs/ft ²
Sands	4000 lbs/ft ²
Gravelly sands	6000 lbs/ft ²
Gravel	8000 lbs/ft ²

Soil that supports bracing or shoring should be compacted and qualify as good soil at least (cohesive, hard, with no water). Professional advice is recommended and may be required for heavy structures such as elevated equipment supports shored at or below grade.

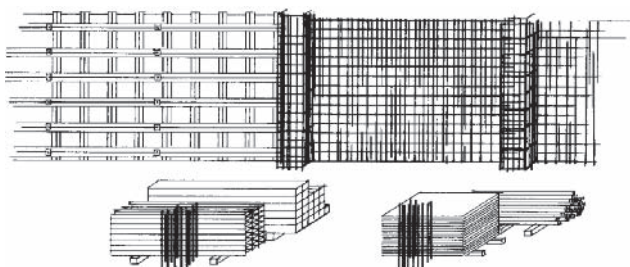


Figure 198
Well-Planned Storage, Access, and Setup

Formwork in these situations is frequently built in place. Planning is required to store material and equipment out of the way, dispose of scrap and debris, and ensure safe, efficient access (Figure 198). Because conditions are often cramped and scrap accumulates quickly, it is important to clean up as work proceeds.

Wall Forms

Wall forms built in place are hazardous to construct. Hazards include

- dowels sticking up from concrete slabs or footings
- unstable work surfaces and access created by poor planning
- manual handling of heavy material such as plywood sheets, panels, wales, and buckets of snap-ties, wedges, and plates
- slippery surfaces at and below grade
- inadequate design

- improper construction.

The best protection against dowels is a wood cover built of lumber at least 1½ inches thick and wired in place (Figure 199).

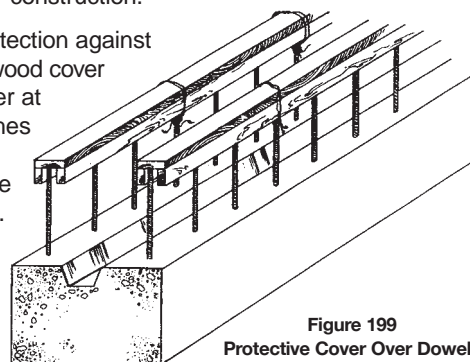


Figure 199
Protective Cover Over Dowels

Starting the Form

Setting up the first form is always hard, heavy, manual work. It calls for enough workers to do the job without overexertion or injury.

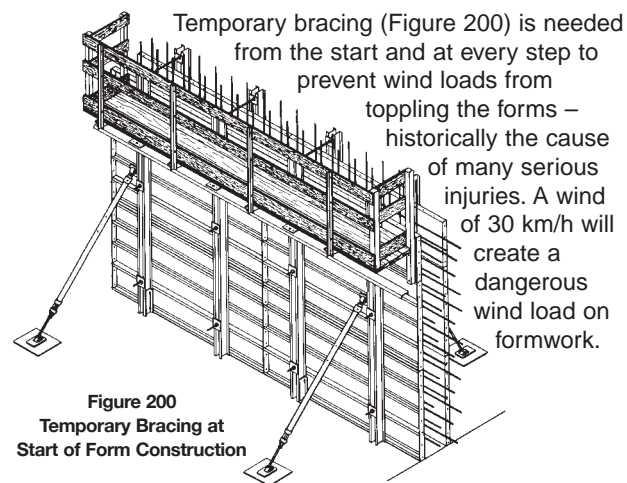


Figure 200
Temporary Bracing at Start of Form Construction

Temporary bracing (Figure 200) is needed from the start and at every step to prevent wind loads from toppling the forms – historically the cause of many serious injuries. A wind of 30 km/h will create a dangerous wind load on formwork.

Access to wall forms is not always given enough thought. Forms more than 2 metres high will require access platforms for workers involved in concrete placing. The platforms can also be used to complete the upper portion of the formwork.

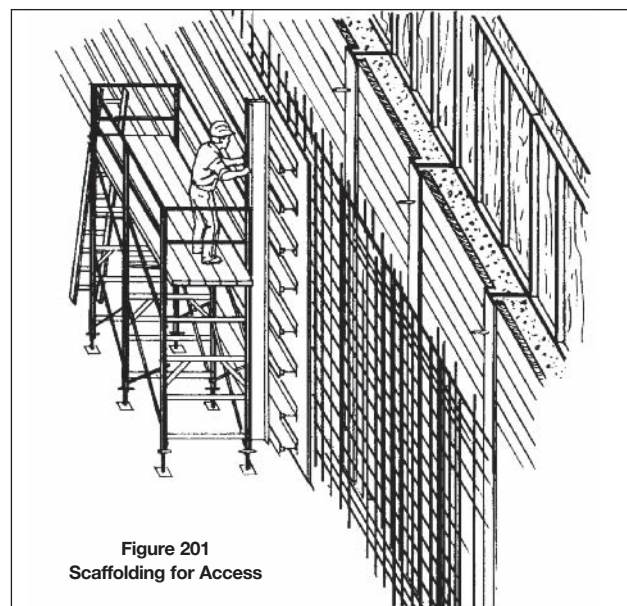


Figure 201
Scaffolding for Access

An alternative is a frame scaffold, which can also be used to install reinforcing steel (Figure 201).

Fall-arrest systems or scaffolds with guardrails must be used where workers may fall more than 3 metres (10 feet), or onto hazards such as projecting dowels (Figure 202). In some circumstances, you must use fall protection when the height is 2.4 metres (8 ft.) or more. (See chapters on Guardrails and Personal Fall Protection.)

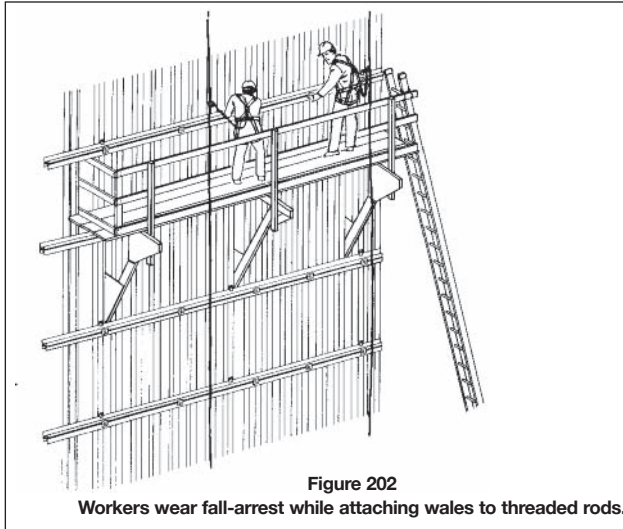


Figure 202
Workers wear fall-arrest while attaching wales to threaded rods.

Materials should be distributed along the work location to minimize further handling. But traffic and work areas must be kept clear for the safe movement and installation of material.

Form Construction

Wall forms must be constructed as designed. The design must indicate clearly what is required.

Some wall forms are designed for specific concrete placement rates expressed in metres of height per hour (m/hr). A wall form in which concrete is placed to a height of one metre in one hour would have a placement rate of 1 m/hr. Slower pouring rates result in lower formwork pressure because the bottom concrete has started to set.

Ensure that ties and braces are installed where indicated on design drawings. Ties should be snugged up. Braces should be securely fastened to forms and wedged or fastened to a support that will not settle or deform under load (Figure 203).

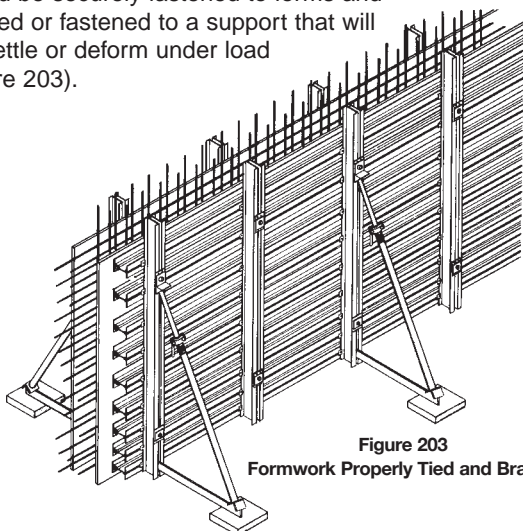


Figure 203
Formwork Properly Tied and Braced

Formwork platforms must be

- capable of bearing at least 50 pounds/foot²
- adequately supported
- equipped with guardrails
- secured at the level or levels where work such as pouring and stripping will be done.

Recommended design pressures for various pour rates and environmental conditions are set out in CSA Standard S269.3 *Concrete Formwork*. The standard defines a number of other design considerations and should be consulted by field staff.

Slab Forms or Falsework Built in Place

With slab forms built in place the major hazard is falls. Injuries are also connected with the manual handling of heavy materials and components.

Forms built in place usually have to be taken down in place. This should be considered at the construction stage. Stability may also be a consideration where the structure is high, carries heavy loads, and is placed on grade as in bridge and overpass construction.

Fall protection is difficult to provide for workers building slab forms in place. That's why planning is essential in the design and erection procedure.

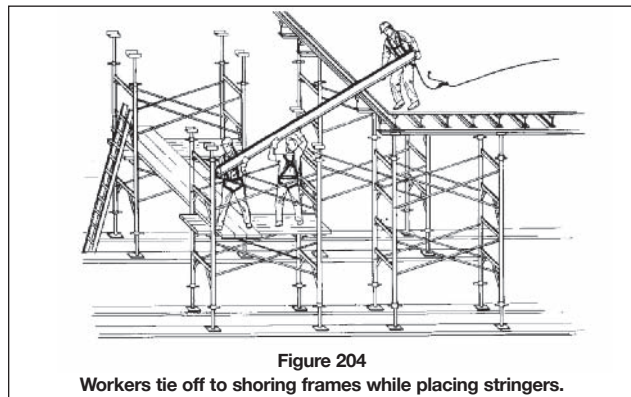


Figure 204
Workers tie off to shoring frames while placing stringers.

Workers should wear a safety harness with the lanyard tied off to the structure of the formwork (Figure 204). This means tying off to the support structure where shoring frame structures are being constructed, tying off to a lifeline when placing plywood panels at a leading edge, constructing a guardrail at the edge of the formwork, or tying off to the support structure when tying it together with tube and clamp. Don't wait for the structure to be completed before tying-off. Make sure you have fall protection at all stages of formwork construction.

Wherever possible, cranes or other equipment should be used to move material, thereby reducing the amount of manual carrying, lifting, and handling.

Shoring towers require special consideration.

- Towers must remain stable during construction and dismantling. Guys may be necessary to maintain stability (Figure 205).
- If towers are to be tied together and braced horizontally, this should be done as work progresses (Figure 206).
- Shoring towers and shores should be installed so they are plumb to within 1/8 inch in 3 feet.
- Shoring towers should be snugged up under the stringers with adjustable base plates and U-heads (Figure 207).

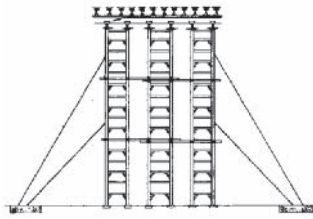


Figure 205
High Guyed Towers

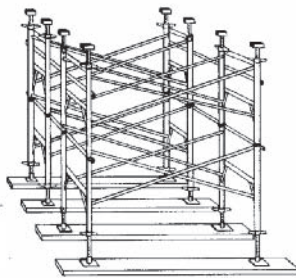


Figure 206
Tube-and-Clamp Tie-Ins for Shoring Towers

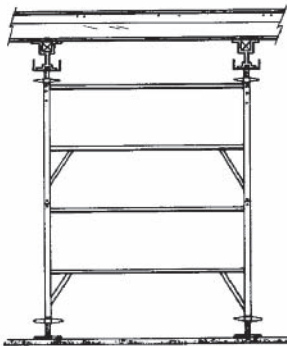


Figure 207
Typical Shoring Tower with Stringers,
Adjustable Base Plates, and U-Heads

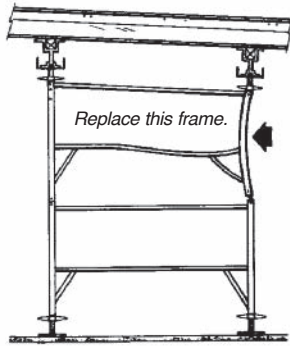


Figure 208
Frame Bent Out of Shape

- If frames do not ride tightly on top of one another after tightening, one or more are out of square and should be replaced (Figure 208).
- With single-post shores, provide adequate lateral bracing (Figure 209). Stairwells and balconies are places where horizontal bracing for single-post shoring systems may be required.

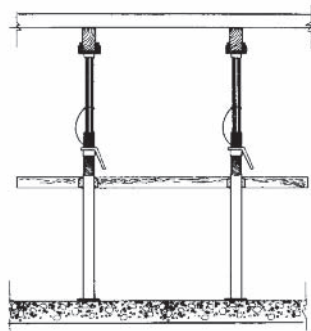


Figure 209
Single-Post Shores with Lateral Bracing

Frequently, supports for built-in-place forms are deliberately left out to allow other work to be done. One example might be a row of single-post shores left out until work below is complete.

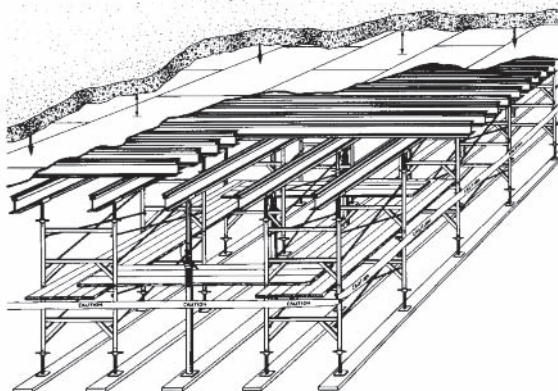


Figure 210
Two Rows of Shoring Frames with Row of Shoring Posts in Centre

Or, an area might be supported temporarily during construction by a few single-post shores that will be replaced later by a shoring tower.

In these and other instances of incomplete formwork, heavy temporary loads such as bundles of rebar or stacks of plywood should not be placed on the structure. Even on completed formwork, make sure that landed material will not overload the structure.

Flying Forms

Flying forms must always be designed by a professional engineer and constructed, hoisted, moved, and set strictly according to the instructions of the designer or manufacturer.

Using forms designed for typical floors in non-typical situations has resulted in serious accidents. Before using any flying form under non-typical conditions, consult the designer or manufacturer. Wall forms should not be extended in height or width, for instance, or slab panels cantilevered without professional consultation. Such situations usually occur with penthouses or mechanical rooms where wall and ceiling heights are greater than for typical floors.

Apart from misuse, hazards with flying forms include

- stability during initial fabrication
- fill-in work between slab panels
- stripping, flying, and re-setting.

In the last category especially, falls are a common hazard. For fall protection, see the next section.

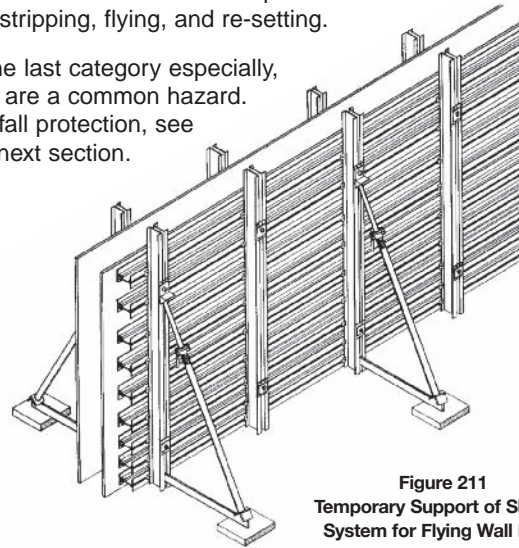


Figure 211
Temporary Support of Shoring System for Flying Wall Form

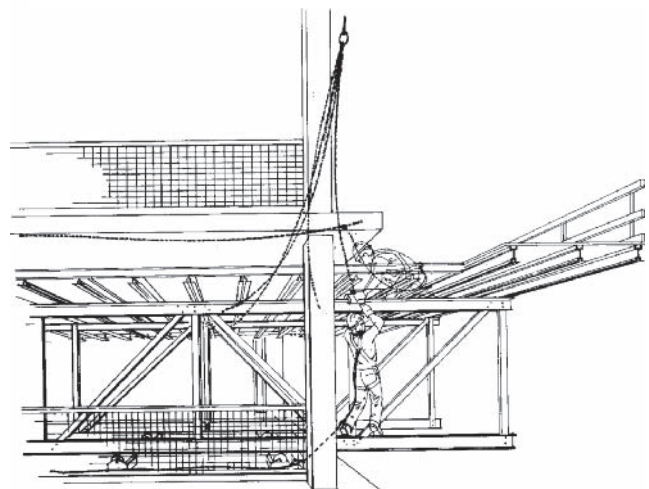


Figure 212 — Helping Worker Above

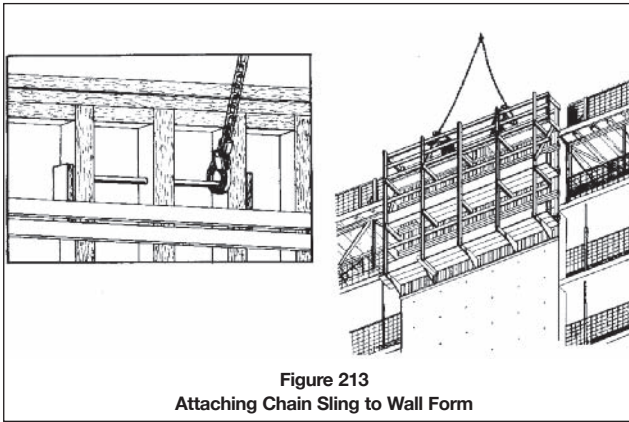


Figure 213
Attaching Chain Sling to Wall Form

Although a flying form is designed to be stable when complete, it may not be stable during fabrication or erection. Temporary bracing or temporary support by a crane may be necessary to ensure stability during certain phases of the operation (Figure 211).

One example is setting up trusses for a flying slab formwork table. The trusses must be held upright to be connected or disconnected. If not adequately supported, they can fall over on workers. Trusses and wall panels have also been blown over by wind during fabrication and dismantling.

Work with flying forms requires adequate space for stacking materials and components. Working in cramped quarters is not only difficult but hazardous.

Fall Protection — Flying Forms

A fall-arrest system should be used by any worker who is

- installing
- pushing a panel out toward the slab edge
- receiving a panel in from the slab edge
- helping other workers attach rigging hardware such as slings (Figure 212)
- getting on and off
- bolting and unbolting wall forms for exterior walls and elevator shafts (Figure 213)
- stepping onto a panel to attach slings to pick points (Figure 214).

Each worker's fall-arrest system must be attached to an individual anchor independent of the flying form. Contractors can provide for anchorage by casting rebar anchors in columns or other areas to be covered over or filled in later (Figure 215).

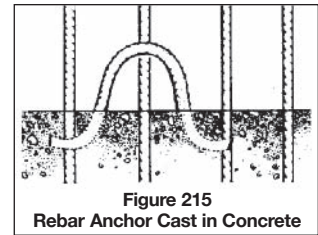


Figure 215
Rebar Anchor Cast in Concrete

Safety Below Flying Forms

The previous section covered the safety of workers flying the forms. But precautions must also be taken to protect workers below the hoisting operation and the public at large, since forms are often swung out over sidewalks and streets. The most efficient protection for workers is to rope off the area below to prevent anyone from entering the area. Pedestrian traffic on sidewalks, as well as vehicle traffic if necessary, should be detoured around the area while hoisting is under way.

Communication

Flying forms are heavy, large, and awkward. To hoist and move them safely requires clear reliable communication. While hand signals are often necessary, direct radio communication between work crew and crane operator is more accurate and effective. Relying on hand signals alone is not recommended.

Stripping

General

Formwork stripping is probably the most hazardous operation in concrete construction. Hazards include

- falling material
- material and equipment underfoot
- manual handling of heavy or awkward forms, panels, and other components
- prying forms loose from concrete presents risk of overexertion, lost balance, and slips and falls.

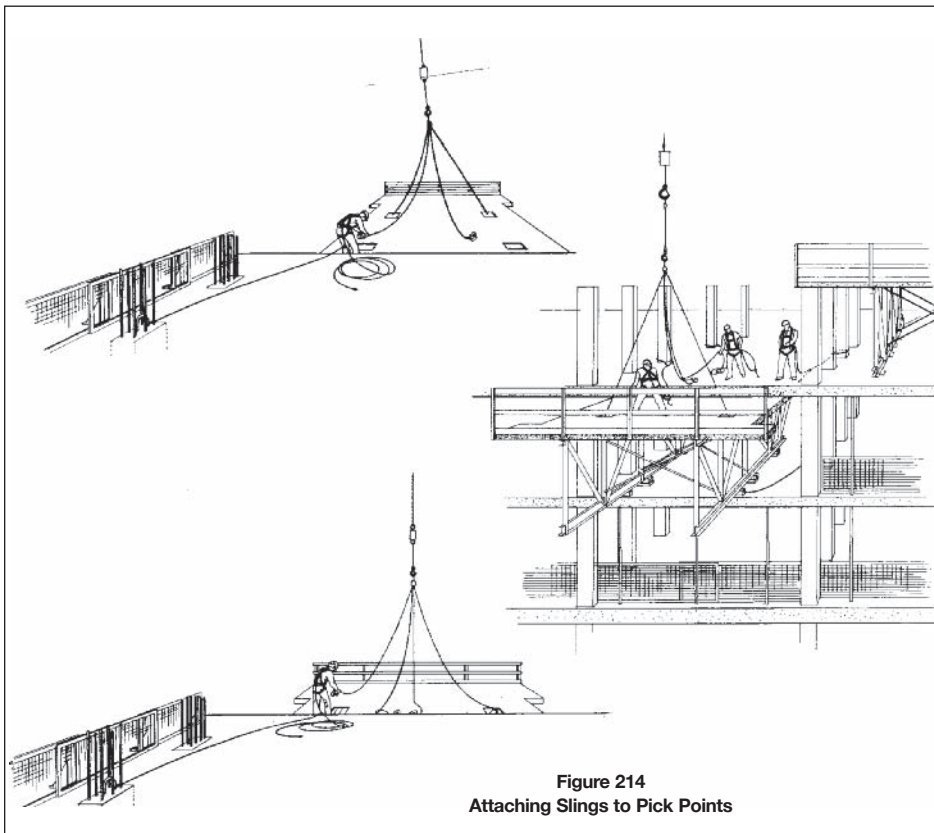


Figure 214
Attaching Slings to Pick Points

Hazards can be reduced by

- planning and providing for stripping when designing and constructing formwork
- supplying facilities and equipment for removing materials as they are stripped
- providing proper tools and adequate access for the stripping crew
- training personnel properly for this and other aspects of formwork.

Forms can be designed with crush plates or filler strips to facilitate removal at difficult intersections of columns, beams, and wall forms. Later, form oils should be used liberally to make stripping easier.

Wherever possible, materials and debris should be removed from the area as work proceeds. This will reduce the need to walk over or work around things left on floor or ground.

Providing carts or cradles can help the crew remove material and reduce the need for lifting and carrying. Material on a cart can be rolled away. Material in cradles can be hoisted off by a crane.

Climbing partially stripped formwork is not only hazardous but unnecessary. Safe access such as rolling scaffolds or powered elevating work platforms should be provided for stripping formwork at elevated locations.

Poor lighting is sometimes a hazard in formwork stripping. Mobile light stands are probably the best solution, since pigtail stringers can easily be knocked down and damaged during stripping.

Wherever possible, stripping crews should be small. This is especially important with knock-down systems. In small crews each person can keep track of what the others are doing. Workers are not as likely to cause problems for each other. Crews of two or three are recommended for knock-down systems. If more workers are required, they can still be divided into small crews working in separate areas.

Other trades and operations should not be allowed in areas where stripping is under way. Given the many hazards involved, the area should be roped off and warning signs posted.

Knock-Down Slab Systems

Stripping these forms is difficult because much of the work is overhead. The usual arrangement involves shoring frames and jacks.

Wherever possible, the work should proceed from one side. That means taking out one row of formwork supported by a row of stringers on shoring frames.

The first step is to back off the adjustable base plates and U-heads in one area, which will in turn lower the stringers, joists, and plywood (Figure 216).

In practice, however, the plywood will stick, especially around beams, column caps, and similar points. Wherever possible, stuck sheets should be loosened and removed before the shoring structure is dismantled.

Stripping should proceed in reverse order to erection. Plywood should be removed first, followed by joists and stringers. The last items to be removed are the shoring frames.

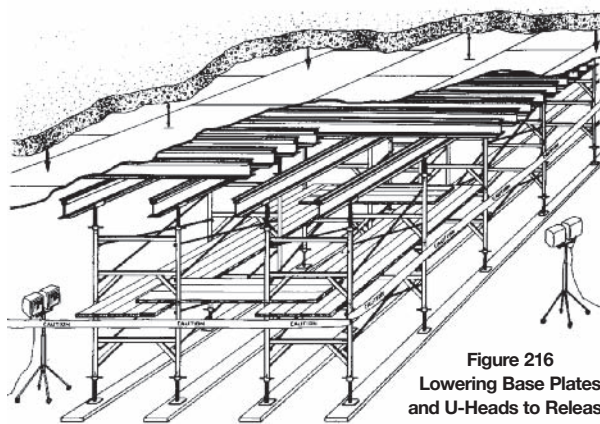


Figure 216
Lowering Base Plates
and U-Heads to Release
Slab Form

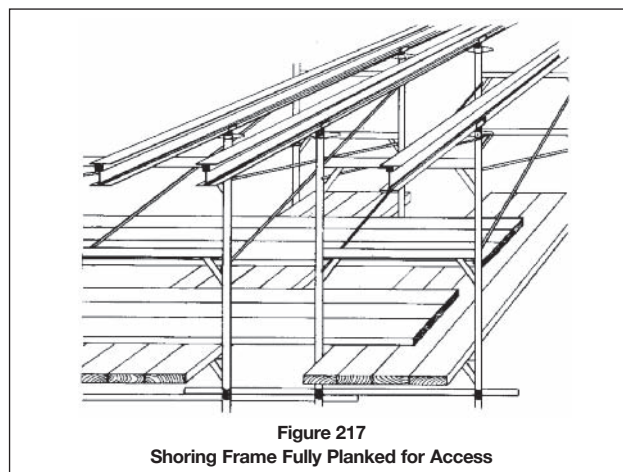


Figure 217
Shoring Frame Fully Planked for Access

When scaffold or shoring frames are used for access, the platform should be completely decked in with planks (Figure 217). Otherwise planks can shift and slide as workers pry or pull at stuck pieces of formwork, lose their balance, and fall. This has been a frequent cause of injuries.

The area where stripping starts should allow access for taking away material as it is dismantled.

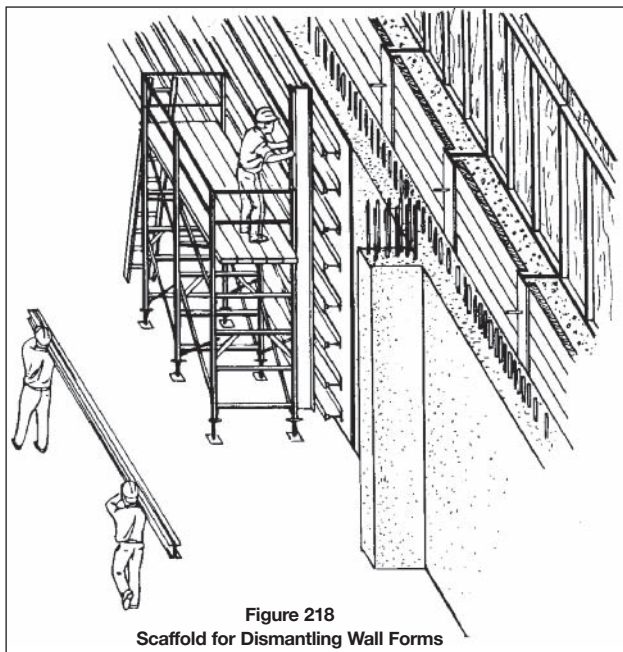


Figure 218
Scaffold for Dismantling Wall Forms

Sound training, well-designed forms, safe access facilities, and immediate and continuous cleanup can help reduce hazards in stripping knock-down slab forms.

Built-in-Place Wall Forms

These forms are frequently of only moderate height. Taller types usually make use of large panels erected and removed by crane rather than hand.

Built-in-place wall forms are usually a stud-and-wale system using some type of ties.

Where workers cannot reach the top of the wall, scaffolding should be provided for removing wales on the upper level (Figure 218). Safe access is essential for the dismantling and manhandling of wales that are frequently long, heavy, and waterlogged.

Material should then be removed immediately to a staging area.

Inspection

Before concrete placing begins, formwork must be inspected and signed off by the designer or a competent person to ensure that it has been constructed to provide for worker safety and to meet job specifications.

In Ontario, formwork requiring design by an engineer must be inspected by an engineer or a designated competent worker. The worker does not have to be an engineer.

A report must be filed stating whether the formwork has been constructed according to the design. Any discrepancies should be cleared up with the design engineer before concrete placing proceeds.

Regardless of the specific responsibility, it is in everyone's best interest to ensure that the formwork has been inspected by a competent person for workmanship, stability, and adherence to design drawings and specifications.

Inspection should start when the forms are being constructed and continue until concrete placing is complete.

Checking line and grade is best carried out while the formwork is being constructed. Shoring structures should be within the alignment limits specified on the design drawings. Line and grade should also be checked during the pour to determine whether formwork is shifting or deflecting.

Dimensions of special features like beams, column capitals, and inserts are best checked during construction. If inspection is delayed until formwork is completed, some details may be covered up or become more difficult to check.

Columns

Check that

- the proper size and type of materials are used
- column ties or column clamps are spaced according to design drawings
- the spacing of ties or clamps is based on a sound assessment of concrete pressure (generally columns are designed for a full liquid head of 150 pounds/foot² times height in feet)
- columns are adequately braced where they are not tied in to a slab-form structure.

Note: For more information on column formwork pressures, refer to CSA Standard S269.3, *Concrete Formwork* or the American Concrete Institute (ACI) standard *Formwork for Concrete* (SP-4).

Wall Forms

Check that

- materials and any manufactured components are as specified in design drawings (size and spacing of studs, wales, and ties are crucial to safety)
- ties are snugged up before concrete is placed
- wedges in wedged systems are tight
- nuts in threaded systems are tight
- bracing conforms to design drawings
- free-standing formwork is braced to ensure stability and resistance to loads during concrete placing
- specified pour rates are not exceeded (wall forms are often designed for specific pour rates; exceeding these rates can cause failure or collapse).

Slab Forms

From a safety perspective, this is the most critical type of formwork. The collapse of slab forms has caused many injuries and deaths, whether from flawed design, unauthorized modifications in the field, or failure to inspect.

Proper inspection demands knowledge, experience, and the ability to

- 1) distinguish between similar but different materials and shoring equipment
- 2) read and interpret design drawings
- 3) identify and clear up with the designer any apparent or real discrepancies in components such as shoring frames.

Check that

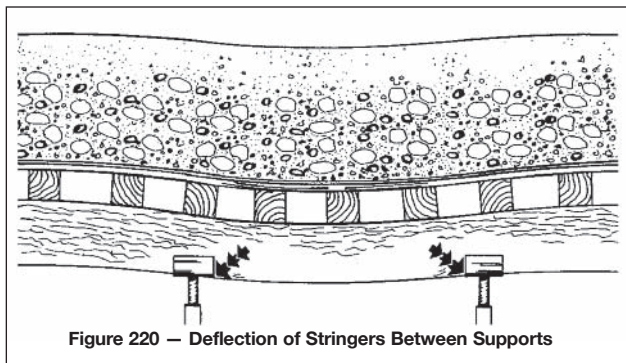
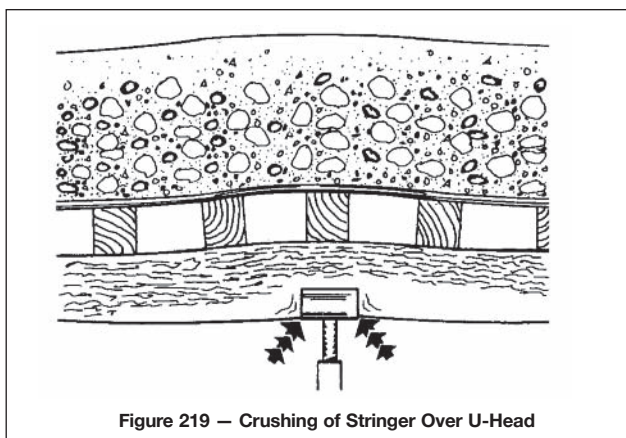
- grade beams or mud sills supporting shoring are properly sized and located
- hazardous soil conditions such as excessive moisture, freezing, and uncompacted soil are reported and discussed with the designer
- shoring frames and jacks are located and aligned within tolerances specified on the drawings
- shoring frames and jacks are out of plumb no more than 1/8 inch in 3 feet
- adjustable base plates for shoring frames and jacks are snugged up
- U-heads are wedged in place
- stringers are the specified size and number, with supports properly spaced
- aluminum stringers have no bent flanges or other damage
- joists are the specified size and properly spaced
- support structures and shoring for beam bottoms and column capitals are constructed according to design
- lateral bracing is provided where required (for instance, on freestanding formwork for bridges and overpasses)
- the bearing surface for lateral bracing is adequate — that is, stable footings or well-compacted soil
- temporary loads such as rebar are not obviously overloading the system.

Concrete Placing

Inspection of forms should continue during concrete placing. Any signs of movement, crushing, or deflection are cause for alarm. Pouring should be suspended until the situation is corrected.

Watch for the following warning signs:

- movement of single-post shoring for slab forms
- movement or deflection of lateral bracing for single-post shores
- movement of stringers on U-heads
- crushing of wooden stringers on U-heads (Figure 219)
- shoring that is not snugged up under stringers
- deflection of stringers between supports (Figure 220)
- deflection of wales or strongbacks on wall forms
- bulging of wall forms
- crushing of wales or strongbacks at washers for ties
- movement of wall forms
- uplifting of battered forms
- pour rates that exceed design specifications.



43 RODWORK

Tools of the Trade

Introduction

This section provides an overview of hazards related to hand and power tools and outlines safe practices. Because of their potential severity, it is important to make every effort to reduce tool-related injuries.

Every year the abuse of hand tools causes eye injuries, puncture-wounds, broken bones, contusions, infections, and severed fingers, tendons, and arteries.

Although some power tools have guards and other safety devices providing a degree of protection, the best controls are hazard awareness, training, and common sense.

The most versatile tools we possess, our hands, are too often damaged by tool accidents. You would be working under a severe handicap without the full use of both hands. They can be caught in machines, crushed by objects, or cut by sharp-edged tools such as knives and saws. They can also be damaged by being burned, fractured, or sprained, unless you are always alert. Your hands are invaluable. Protect them from injury by following safe work practices with tools.

Eyes are highly susceptible to injury from tool use but eye injuries are almost always preventable. Use the guards and personal protective equipment which we all know are needed but are so easy to overlook.

Noise is unavoidable on some jobs, both from tools and from the working environment. Exposure to excessive noise can impair hearing. Prolonged exposure can result in permanent hearing damage and eventually deafness. Hearing protection should be worn whenever there is exposure to excessive noise.

Common Causes of Accidents

Typical causes of hand and power tool accidents in construction include

- using the wrong tool for the job
- tools falling from overhead
- sharp tools carried in pockets
- using cheaters on tool handles
- excessive vibration
- using tools with mushroomed heads
- failure to support or clamp work in position
- carrying tools by hand up or down ladders
- using damaged electrical cords or end connectors
- failure to use ground fault circuit interrupters (GFCIs), especially outdoors.

Safe Practices

Basic hazard awareness and common sense can prevent serious injuries caused by hand and power tools. As a general rule, follow the safe practices listed below.

- 1) **Dress right for the job.**
Wear the clothing and equipment designed for use with the tools of the trade (Figure 1.1).

Always wear eye protection. There is a constant risk of flying particles and dust when using hand and power tools. Appropriate eye protection is essential and must be worn by the user and others nearby.

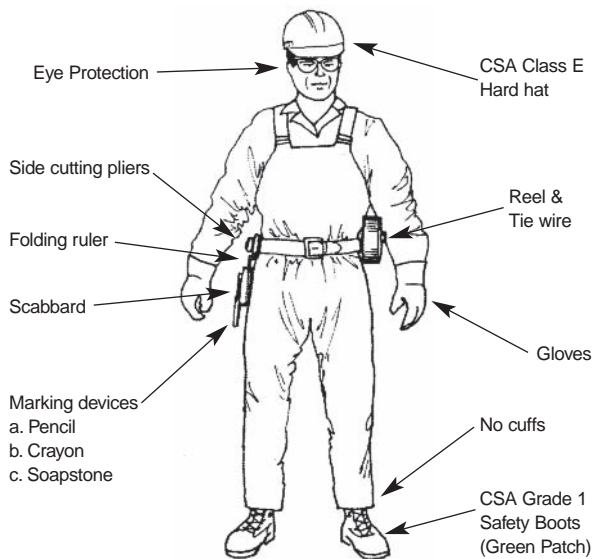


Figure 1.1: Rodworker ready to place reinforcing steel

- 2) **Use the right tool for the job.**
Using a cheater bar or pipe on a wrench handle or using pliers as a hammer are examples of the mistakes which commonly lead to accidents and injuries.
- 3) **Use tools as recommended by the manufacturer.**
For example, always use a proper wrench or hammer, not pliers. Misusing pliers will exert more force on the tool than it was designed for and cause wear, breakage, and injury.
- 4) **Remove damaged or broken tools from service.**
Hammers with cracked or loose handles, wrenches with worn jaws, damaged hickey bars, damaged extension cords, and ungrounded tools are all unsafe and should be removed from service and be either repaired or destroyed.
- 5) **Maintain tools in safe operating condition.**
Pliers with worn teeth can cause personal injury if they slip while you're tying wires.
Keep handles secure and safe.
Don't rely on friction tape to secure split handles or to prevent handles from splitting. Check wedges and handles frequently. Be sure heads are wedged tightly on handles. Keep handles smooth and free of rough or jagged surfaces. Replace handles that are split, chipped, or that cannot be refitted securely.
Keep cutting edges sharp.
Sharp tools make working easier, improve the accuracy of your work, save time, require less effort, and are safer than dull tools.
- 6) **Never climb ladders with tools in your hand.**
Tool holders and pouches free the hands while you are climbing or working on ladders, scaffolding, and other areas where access may be difficult. To carry tools up and down between levels, put them in substantial bags or boxes and raise and lower them with strong ropes.
- 7) **Non-ferrous, spark-resistant tools are recommended** where flammable materials or

explosive dusts or vapours might be present. These tools, such as brass or copper hammers or mallets, should always be used with caution. Remember—they may not guarantee safety in all explosive situations, such as the presence of gasoline vapours. It is always safer to eliminate the hazard by ensuring a safe atmosphere through isolation, ventilation, or purging.

- 8) **Protect the cutting edges of tools when carrying them.** Carry them in such a way that they will not be a hazard to yourself and others. Carry pointed or sharp-edged tools in pouches or holsters.
- 9) **Keep hand tools clean.** Protect them against damage caused by corrosion. Wipe off accumulated dirt and grease. Dip the tools occasionally in cleaning fluids or solvents and wipe them clean.
- 10) **Lubricate** adjustable and other moving parts to prevent wear and misalignment.
- 11) **When swinging a tool**, be absolutely sure that no one else is within range or can come within range of the swing or be struck by flying material.
- 12) **Falling tools** are a dangerous hazard for workers below. Keep track of tools, especially when working at heights on scaffolds or other access equipment. An unnoticed file or chipping hammer, if accidentally kicked off the work platform, is a deadly missile, as well as a tripping hazard for you. Where practical, tie tools off when working at heights.
- 13) **Hearing protection** should be worn whenever there is a risk of exposure to excessive noise. Noise is a hazard inherent in the construction industry: from your tools, from those nearby, and from the operating environment. Exposure to excessive noise can impair hearing. Prolonged exposure can result in permanent hearing damage and eventually deafness. Although power tools are only one of several possible noise sources, efforts should be made to provide the least noisy power tools which will still do the job.

Inspection and Repair

Tools should be inspected by a person qualified, through training and experience, to determine the safe condition of the tool. Worn or damaged tools should be tagged **“DEFECTIVE—DO NOT USE”** and returned to the shop for repair or replacement.

Regular inspection of all tools is necessary and should cover tool maintenance and service as specified in the operator’s manual. Observing the handling and storage of tools should also be a part of the inspection process. Responsibility for inspection is usually left to the supervisor. However, tools should be checked daily by those who use them.

Hand tools that get the heaviest use and abuse such as chisels, hammers, and wrenches should be inspected frequently and regularly.

Maintaining and repairing tools properly requires the right facilities and equipment. Only persons skilled in the repair of tools should be allowed to do so. Otherwise tools should be sent out to a qualified repair depot.

Use

The misuse of hand tools is a common cause of injury in construction. In many cases, the injury results because it

is assumed that everyone knows how to use most common hand tools. This is not the case.

It is the responsibility of the supervisor and employer to ensure that workers are trained in the safe and proper use of hand tools.

Hammers and Sledges

Hammers are made in various shapes and sizes for specific jobs. They should be selected and used only for the purpose intended. Hammers come in many types and styles, and although not a standard tool-belt item for rodworkers, they receive periodic use.

Basic Rules - Hammers

- Always wear eye protection.
- Make sure the handle is tight; never use a hammer with a loose or damaged handle.
- Always strike the work surface squarely with the hammer face; avoid glancing blows.
- Hold the hammer with wrist straight and hand tightly wrapped around the handle.
- Look behind and above before swinging the hammer.
- Never use a hammer to strike another hammer.
- Discard any hammer with dents, cracks, chips or mushrooming; redressing is **not** recommended.
- When striking another tool (chisel, punch, wedge, etc.), the striking face of the hammer should have a diameter at least 1/2 inch (1-1/4 cm) larger than the struck face of the tool.
- Never weld or reheat-treat a hammer.

Chipping hammers are designed for chipping slag off welds or burned edges. They can come in a variety of styles and handles. These hammers have long, slender or tapered points or edges, and can be resharpened many times.

Cutting Hand Tools

Rod and bar cutters

There are a few general precautions which should be followed when using these tools.

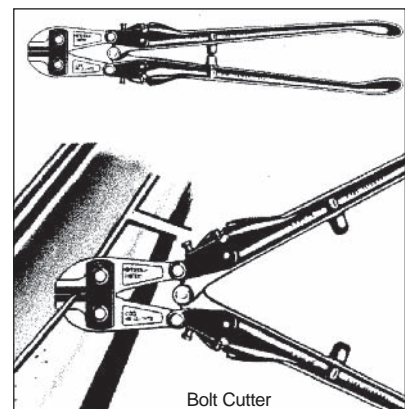
- Wear eye protection.
- Keep fingers clear of jaws and hinges.
- Cut ends can fly and cause injury; try wrapping burlap or a rag around the jaws while cutting.

Bolt Cutters

Bolt cutters typically come in lengths of 18” to 36” with the larger ones able to cut mild-steel bolts and rods up to 1/2” diameter, as well as other materials, such as wire rope.

Keep jaws at right angles to material.

Don’t pry or twist—chips can break off and fly dangerously, as well as damage the blade.



Manual Rebar Shears

These can be useful for cutting up to 15M (#6) bars or bigger.

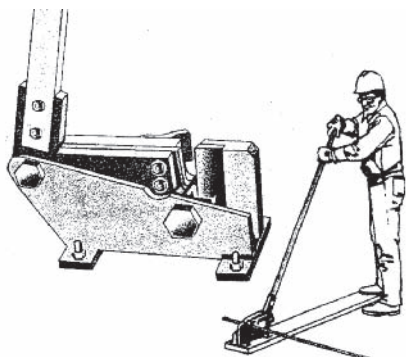


Figure 1.2
Manual Rebar Shear

Holding Tools

Wrenches

Regardless of the type of wrench, there is always the hazard that the wrench may slip off the work, or that the work may suddenly turn free. There is also the possibility that the wrench or work may break. The user should always be braced so as not to lose balance and be injured should the wrench get free for any reason. Always inspect a wrench for flaws, damaged parts, or wear, which can cause it to slip and damage fasteners.

There is a correct wrench for every job. If the wrench is too big it may not grip securely. Slippage and damage of the wrench or fastener may result, or the thread may be stripped because of over-torquing. Where possible, use penetrating oil to loosen tight nuts and bolts.

- Always grip the wrench so it will not cause injury if it slips.
- Use the correct jaw to avoid slippage. Box wrenches are safer than open-end wrenches since they are less likely to slip. Solid open-end wrenches of the correct size are generally more secure than an adjustable wrench, especially on hard-to-turn items.
- Discard any damaged box or open-end wrench. Don't attempt to repair a wrench with rounded or damaged points on the box end, or worn or spread jaws on the open end.
- Face adjustable wrench forward and turn wrench so pressure is against the permanent jaw (Figure 1.3).

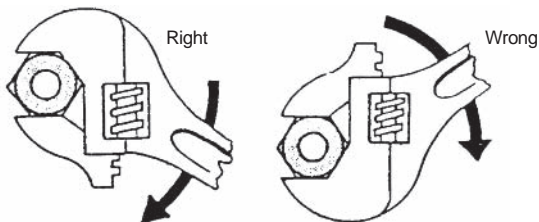


Figure 1.3

- Always **pull** on a wrench whenever possible. Do not push.
- Never overload a wrench by using a pipe extension on the handle or by striking the handle with a hammer. This can weaken the metal of the wrench and cause the tool to break. Heavy-duty box wrenches with extra long handles and “hammer” or striking-face wrenches

are available for these jobs. The striking-face wrenches with 12-point box openings are designed for striking with a ballpeen or sledge hammer. Both offset and straight styles are available (Figure 1.4) but the straight type should be used when possible.

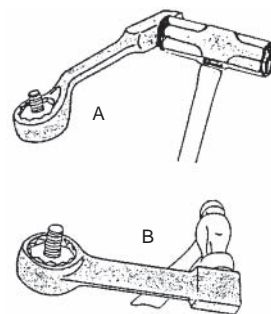


Figure 1.4: Hammer wrenches
(A) offset hammer wrench
(B) straight hammer wrench

Socket Wrenches

Socket wrench sets offer a multitude of options in both the types and sizes of the sockets and the variety of drivers available, including ratchet, universal, speeder, and their many extensions and adapters. When using adapters and adapting down in size, be careful not to over-torque a smaller socket and fastener with a larger driver.

Always use the correct size of socket; make sure it fits snugly. An oversize or sloppy fit can cause slippage and possible injury, as well as causing wear to both the socket and the fastener.

Never use “hand” sockets on a power drive or impact wrench. Hand sockets are normally brightly finished while power and impact sockets have a dull finish and usually thicker walls.

Pliers

Pliers, or specifically side-cutting pliers, are the rodworker’s basic tool for tying reinforcing bars in place. The pliers used are usually 7-inch, 8-inch or 9-inch, although size is an individual preference.



Figure 1.5:
Rodworkers’ Side-Cutting Pliers

Many rodworkers prefer to use “high leverage side-cutting pliers” which are designed to give increased leverage while cutting.

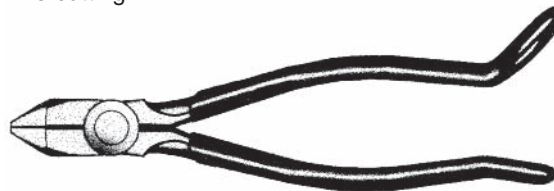


Figure 1.6: Rodworkers’ High Leverage Pliers



Figure 1.7: Rodworkers’ Diagonal Side-Cutting Pliers

Pliers are frequently misused. They are meant for gripping and cutting and are not to be used as a wrench because their jaws are flexible and may slip.

Basic Safety Rules - Pliers

- Choose pliers with enough space between the handles to prevent pinching of the palm or fingers.
- Replace pliers when teeth or cutters are worn—they can slip and cause injury.
- Select pliers that have a grip span of 6 cm to 9 cm (2 1/2"-3 1/2").
- Pull on pliers—don't push.
- Side-cutting pliers may cause injuries when ends of wire are cut and fly into a worker's eye.
- Eye protection should be worn when using side-cutters.
- Always cut at right angles; never rock from side to side against the cutting edges.
- Pliers used for electrical work should be insulated. But you must still shut off power first.
- Remember—cushion grips on handles are for comfort only and are not intended to protect against electrical shock.
- Never expose pliers to excessive heat; this may draw the temper and ruin the tool.
- Don't use pliers as hammers; they might crack, break, or be nicked.
- Pliers should not be used to tighten nuts or bolts; use a proper wrench.

Pipe Wrenches

Pipe wrenches have been the cause of serious injuries when used on overhead jobs. Wrenches can slip on pipes or fittings, causing the worker to lose balance and fall. Pipe wrenches, straight or chain tong, should have sharp jaws and be kept clean to prevent slipping (Figure 1.8).

- The adjusting nut of the pipe wrench should be inspected frequently for cracks. A cracked nut may break under strain, causing wrench failure and serious injury.
- Use a wrench the right length and size for the job. A wrench that is too small will not provide enough leverage or grip. A wrench that is too big may strip the pipe threads or break the work, causing a sudden slip or fall.
- Face the pipe wrench forward. Turn the wrench so that pressure is against the heel jaw.
- Never use a "cheater" to extend a wrench handle to increase leverage. The cheater may strain the wrench or the work to the breaking point.

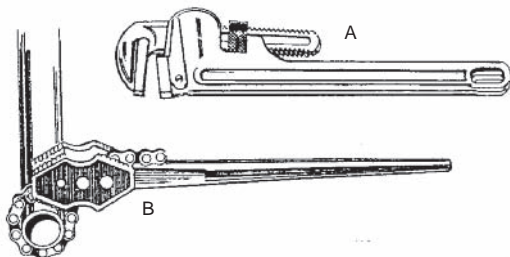


Figure 1.8: Some pipe wrenches: A Straight, B Torque Wrench Type

Hand Benders and Hickey Bars

- Generally suitable for 15M to 25M bars.
- Inspect tool before using.
- Make sure your footing and body position are such that you will not lose your balance.

- Take care when straightening or bending bars or dowels at the open edge of a structure. Rebar tends to be brittle and can snap if bent too much. Make sure you're tied off safely before pushing or pulling outwards on bars along open edges.
- Avoid pinch points.
- Ensure there is enough clearance to make the bend.

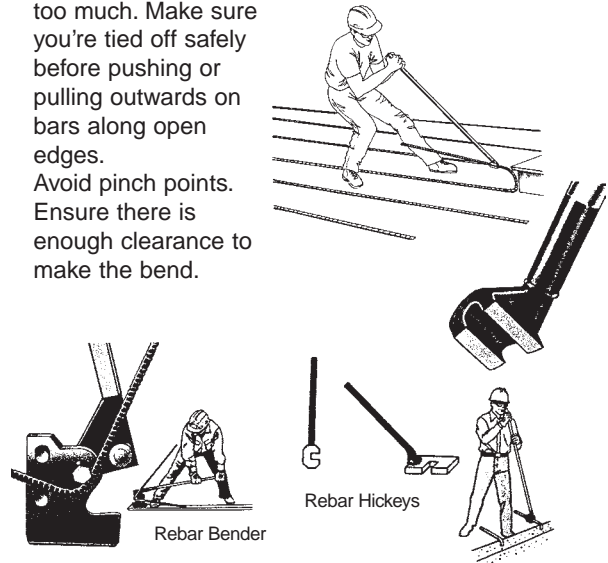


Figure 1.9: Hand Benders

Powered Rebar Fabrication Tools

The majority of rebar fabrication is done in the shop but there may be times when field fabrication is required, especially on relatively remote worksites. A selection of such tools is shown in Figures 1.10, Figure 1.11, and 1.12.

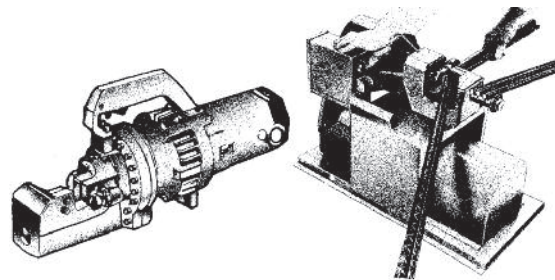


Figure 1.10: Electric or electric/hydraulic shears and cutters

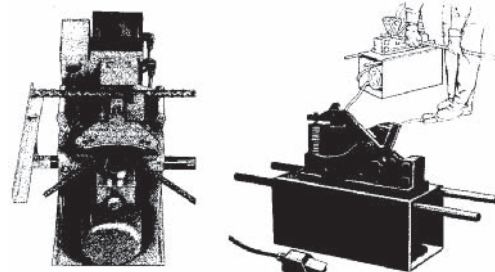


Figure 1.11: Electric or electric/hydraulic shears and cutters

Basic Precautions

- Be sure to wear eye protection.
- Keep fingers clear of blade or grip areas.
- Protect power supply lines from physical damage, such as traffic and sharp edges.

For Electric Tools

- Check that power supply matches equipment requirements.

- Use a ground fault circuit interrupter (GFCI).
- Have damaged cables replaced.

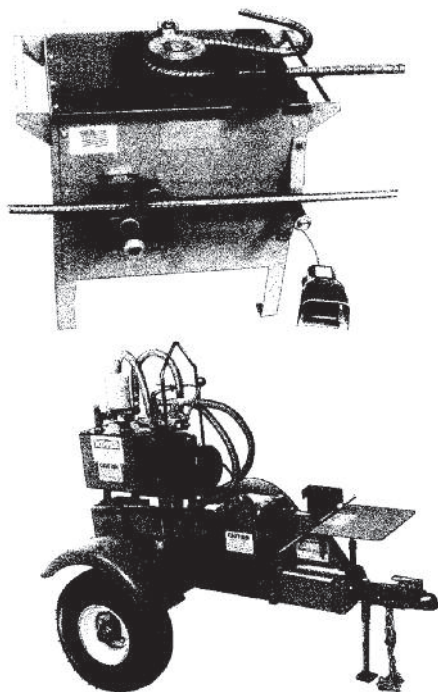


Figure 1.12: Electric/hydraulic benders and bender/cutters

For Hydraulic Tools

- Replace damaged or worn hoses.
- Make sure connections are clean and tight.
- Make sure pump and tool are matched.

Rebar-Tying Machine

The risk of work-related musculoskeletal disorders, such as low-back injury, while tying rebar with pliers is well documented. The high rate may be related to the frequency and repetition of two factors:

- 1) the static, awkward trunk posture while performing ground-level rebar tying; and
- 2) exposure to forceful hand exertion while using pliers to tie rebar.

One way to improve posture is to use an automatic rebar-tying machine. This is a battery-powered electric tool that can be applied where bars cross. When you press the trigger, the machine feeds the wire around the bars, twists it, and cuts it (see photos).



Research conducted by the Rodworkers' Labour-Management Health and Safety Committee has found that working with the rebar-tying machine can decrease repetitive forceful wrist activities such as the bending, twisting, and lateral bending associated with manual tying. Furthermore, using the rebar-tying machine can decrease static bending of the trunk, which in turn can decrease the risk of low-back injury.

When using the rebar-tying machine, several issues should be considered.

- Choose a rebar-tying machine that allows tying steel rebar at a comfortable back posture.
- Select a rebar-tying machine that can tie various rebar sizes.
- For slab-on-grade rebar, tying rebar with the rebar-tying machine will require the use of a long steel hook to lift rebar off the ground (see Photo 1).
- Many rebar-tying machines require warm-up during cold weather. Proper tying tension of the tool must therefore be adjusted on cold days.
- On very hot summer days, let the machine cool down during regular breaks and lunch. This can be done by placing the machine in a cool shady area.
- Working with the rebar-tying machine is very productive for a crew of 4-5 workers per site.
- The rebar-tying machine can help workers with low-back or hand injuries return to work.



Photo 1

Work Belts

When installing reinforcing steel on a vertical surface consisting of horizontal steel bar, a scaffold must be provided if the working height is more than 12 feet (3.7 metres). If a scaffold cannot be erected, a worker must wear a work belt while performing rebar work.

A work belt is a belt that has a back support pad and a connecting hook at the front and is capable of supporting a worker. A work belt allows both hands freedom of movement for work on a vertical wall. The belt is designed to secure the worker safely in position at the point of work but is not designed to arrest a free fall. Therefore a full-body harness with a secure anchorage system, such as an existing structural feature or temporary fixed support, must be used when a worker may fall more than 10 feet (3 metres) or onto hazardous objects or substances.

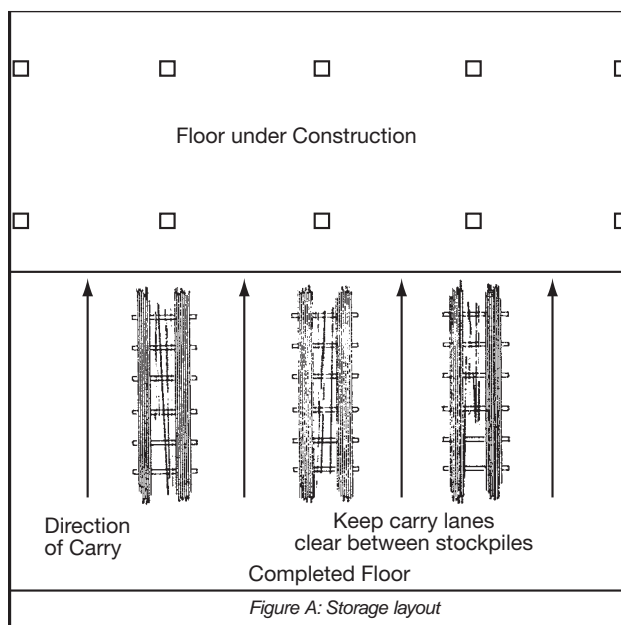
Site preparation and storage

1. Work Areas

- Work areas for cutting or bending should be laid out in advance to ensure safe and efficient operation.
- When stockpiling standard-size reinforcing steel for on-site fabrication ensure that a good solid base is provided for storage. If the rebar is to be piled high, use long sleepers to ensure a level and safe storage area.
- Keep work areas clear of clutter, debris, and scrap material.
- Keep a box or barrel close by for the disposal of scrap.

2. Preparing On-Site Storage Areas

- The area where the material is to be stored should be as level as possible, dry, well-drained, and with good access.
- Avoid storing materials under powerlines, especially if hoisting equipment is being used to move it (O. Reg. 213/91, Section 37).
- 4x4 sleepers should be used to keep the steel off the ground and to allow slings to pass freely under the load. Make sure there is adequate blocking available before reinforcing steel is delivered.
- Storage areas should be as close to the work area as possible, whether steel will be handled by crane or carried by rodworkers.
- The formwork contractor and general contractor should be consulted before setting up storage areas so that they are aware of potential weights to be stored in each area. Ensure that steel stored on floors does not overload the structure, and that reshoring is in place on newly poured slabs.
- To prevent spill-over when they are unbanded, bundles should be stored at least 1.8 metres (6 feet) away from all slab edges and openings.
- Wherever practicable, storage areas should be well laid-out with clear and direct access to work areas.
- Store steel so that bars are free of mud, oil, grease, etc.
- In general, a clean work area is a safe work area. Store materials away from travelled walkways.

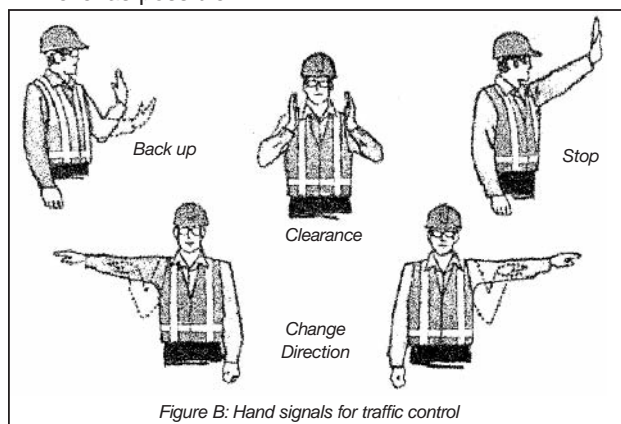


Unloading and Storage Precautions

- Post “DANGER” signs and cordon off unloading areas as required.
- Serious accidents can occur if banding or tie-downs for bundles are released without containment, and materials spill over.
- Be sure to communicate with the driver about unloading procedures.
- Land and block the load before unhooking and unslinging it. Lower loads onto adequate blocking to prevent damage to slings.
- Make sure identification tags are clearly visible in order to avoid extra handling.
- Space the bundles so that they can be picked up without having to move other bundles. If bundles must be stacked in layers, put sleepers between each layer.
- Immediately after cutting, dispose of banding material, waste wire, or any other garbage in proper containers so that it does not become a hazard.
- Near openings, arrange material so that it cannot roll or slide in the direction of the opening.

Positioning the Truck

- Position the truck as close to the crane-unloading area as possible to avoid overreaching by the crane.
- The truck should be positioned on terrain that’s as level as possible.



- Keep the truck and crane away from overhead powerlines.
- Trucks backing up should be directed by a competent signaller.
- Truck wheels should be blocked or chocked during unloading.

Mounting and Dismounting from Truck Beds

Many accidents have occurred when rodworkers have gotten on or off a flatbed truck. Individual situations will vary, but a common-sense approach should be followed.

- Before mounting the truck, scrape off your boot soles to avoid slips.
- Mount the truck platform in full view of the crane operator or signaller so that you will not be struck by the load or the crane hook.
- Climb up and down facing the truck, maintaining 3-point contact at all times (two hands and one foot, or two feet and one hand).
- If steps and handrails are provided, use them. Tires and hubs don't provide good footing.

Barring-Off

On occasion, reinforcing steel must be unloaded from flatbed trucks without the use of a crane. This is done by prying the load over the edge with a pry bar. It's called barring-off. Barring-off should be avoided where possible. Otherwise, exercise extreme caution.

When barring-off:

- The sleepers upon which the load is placed, usually 4 x 4 timbers, should be bolted or secured to the truck bed to prevent fly-up.
- Sleepers that are not secured to the truck can react violently when the load is released over the side of the truck. Sleepers have been known to jump 6 metres (20 feet) in the air. If sleepers are not bolted down, stand clear when the load is released.
- To avoid over-exertion, use pry-bars strong enough and long enough to move the steel without causing undue stress on your body.
- Avoid standing on uneven surfaces when prying. For the best footing, stand on a clear, level area.
- Rodworkers should ensure that the drop area is clear of equipment, materials, and people.

Rebar Storage

- Store near area of use.
- Use wooden spacers to separate piles.
- Check loading on floors.
- Make sure reshoring is in place on newly poured slabs.
- Keep rebar off ground on dunnage (4x4 sleepers).
- Make sure that the identification tags are clearly visible to avoid extra handling.
- Store so that bars are free of mud, oil, grease, etc.

Moving Steel to Placing Area

1. Work Rotation To Reduce Fatigue

Tasks should be rotated when and where possible to avoid fatigue and stress caused by working in an awkward posture for long periods.

For example, take a rest from carrying by switching jobs with a rodworker tying rebar. A good rule of thumb is to change jobs at two-hour intervals.

2. Access To Work Areas

Reasonably level and clear walkways should be provided and used. Carrying steel over rough terrain leads to accidents.

- All planking used for trench crossings, ramps, and other walkways must conform to regulations:
 - Grade: No. 1 spruce or better
 - Thickness: 51 mm (2" full size)
 - Width: 25.4 cm (10" full size)
 - Span: maximum of 3 metres (10 feet).
- Planked walkways should be used on top of the thick slab reinforcing encountered in bridge work, subway, and reactor work, and similar projects, where the depth of the slab presents a hazard to any worker stepping through the mat.
- Provide walkways over openings or beam pockets in slab forms.
- Do not carry bars up or down ladders. It is safer and easier to pass bars from one level to the next. Bars should never be thrown or dropped into a lower area. If the distance is too far to pass bars by hand, use hoisting equipment.
- Storage areas should be organized so that carrying is kept to a minimum. Lay bundles parallel to walkways and out of the way of other activities.
- Organize layout so that you work *towards* the steel pile, not away from it.

3. Adverse Conditions

Take steps to minimize the hazards resulting from weather conditions—such as mud, snow, rain, ice and wind—as well as form oil.

- In extremely high winds, stop hoisting operations.
- Clear icy areas before work proceeds.
- Wet, muddy areas should be dried up or avoided if possible.
- Avoid walking on oily rebar.

4. Working Below Grade

- Before starting to work below grade level, as in caissons, trenches, and excavations, ensure that embankments are properly sloped or shored.
- Excavation walls should have a clear space at the top at least 1 metre wide. Ensure that there is no loose material on top or clinging to the sides, which can fall into the work area. This could include rocks, stones, frozen clumps of earth, and building materials.
- Changing weather can seriously alter working conditions. It is not enough to inspect excavation walls before starting work. Be sure to watch for hazards as the day progresses. Freeze/thaw cycles can cause banks to give way.

Below-Grade Hazards

See the chapter on Trenching in this manual for the required safety controls for work in trenches and excavations.

Workers placing and fabricating steel below-grade must often work in areas where movement is restricted. They must be constantly aware of hazards underfoot and overhead. You need to take special care considering the rough terrain and the risk of debris, material, or equipment rolling into the workspace. We recommend having someone topside to pass down material and keep an eye out for hazards.

Excavations should be kept essentially dry. Water should be pumped out. Mud should be cleared off and replaced by compacted granular material in work areas and on surfaces where concrete will be placed. Mud presents a slipping hazard and can lead to inferior construction if not removed or replaced.

Formwork and reinforcing construction for footings and grade walls may begin before excavation in the area is complete. Trucks and excavating equipment put workers on foot at the risk of being struck down or run over.

Wherever possible, these operations should be roped off from other work, such as excavation or pile-driving (see Figure C). We strongly recommend having separate access ramps for vehicles and workers. Stairs are an even better alternative for personnel on foot.

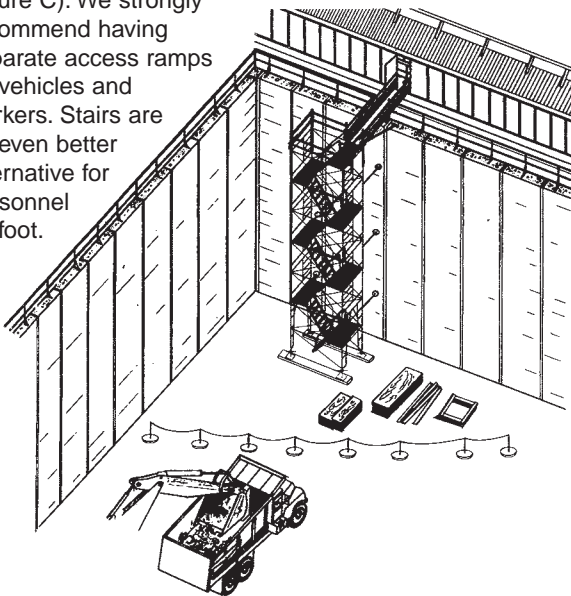


Figure C: Rebar construction and formwork roped-off from other operations

At the beginning of a project, develop a plan for storing material and equipment out of the way, disposing of scrap and debris, and ensuring safe, efficient access (see Figure D). Because conditions are often cramped, and

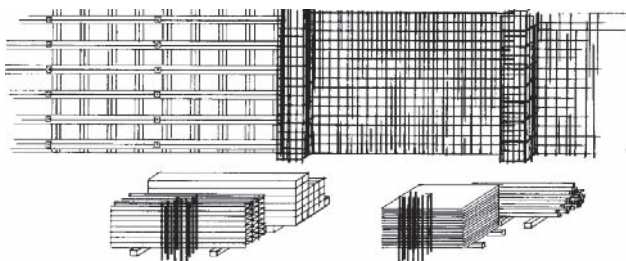


Figure D: Well-planned storage, access, and setup

scrap accumulates quickly, you need to clean up as work proceeds.

Wall Construction

It can be hazardous to construct walls which are built in place. Hazards can come from both the rebar and existing partial forms and include

- dowels sticking up from concrete slabs or footings
- unstable work surfaces and access (poor planning)
- manual handling of heavy material
- slippery surfaces at and below grade, and on steel
- inadequate design
- improper construction.

Protection must be provided against protruding dowels and rebar, which can be a hazard. There are many types of protective caps available for rebar or dowels. Select the type of cap that is appropriate for the protection you require. For example, if you could fall on the rebar, make sure the caps are strong enough to prevent the rebar from punching through and impaling you.

The Construction Regulation (O. Reg. 213/91), Section 36 addresses "Protruding Hazards" and states that: "If a formwork tie, reinforcing steel, a nail or another object protruding from concrete or another surface may endanger a worker, the protrusion shall be removed, cut off at the surface or otherwise protected as soon as practicable."

Proper Tying and Straightening

Tying

- Before starting work, ensure that all openings and slab edges are protected by proper guardrails or coverings sturdy enough to prevent falls.
- 16-gauge wire is generally used for tying rebar unless a different size has been specified by the project engineer.
- The ends of tie wires should be bent over to prevent injury to workers rubbing or brushing against them.
- Never move backward when tying. Always advance to your work.
- When working on walls or columns use correct ties to prevent rebar from slipping.

Straightening

Quite often a rodworker will be assigned to straighten dowels projecting from a previous pour.

- Take particular care when straightening dowels at the open edge of a structure. Reinforcing steel tends to be brittle and can snap off when bent too much. This sudden break in a dowel rod has caused too many rodworkers to fall. Never push or pull outward on the rebar without first making sure that, if required, you are properly equipped with a fall protection system including a full-body harness

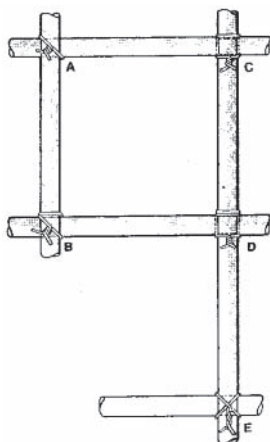
tied off to a secure part of the structure.

- A hickey or pipe sleeve should be used to straighten bars larger than 15M.
- Mechanical help, such as a hydraulic jack, may be required to straighten bars over 30M.

Common Ties

There are various methods of hand-tying the intersections of bars. Some of the most common are the following:

- A. **Single Tie** is used normally to secure the bars in position against displacement.
- B. **Wrap and single tie** is normally used when tying wall reinforcement, holding the bars securely in position so that the horizontal bars do not shift during the construction progress or during concreting.
- C. **Saddle tie** is used for tying bars in beams, columns and walls in position.
- D. **Wrap and saddle tie** is used to secure heavy bars that are pre-assembled into units to be lifted by crane. These ties are subjected to considerable strain.
- E. **Figure-eight tie** is sometimes used in walls in place of the wrap and single tie.



Post-Tensioning

Pre-stressing is a means of achieving shallow, long-span, and attractive structural elements in concrete. Post-tensioning is generally used for on-site pre-stressing as opposed to carrying out precasting operations in a yard.

Post-tensioning essentially involves pouring the concrete member. Forming holes running the length of the member, where the steel tendons are located, allow the concrete to cure, and tensioning the tendons to high stress against steel anchors compresses the concrete member. Tendons usually have one fixed and one movable or floating stressing end.

Post-tensioning is not a common part of many rodworkers' activities, but it is a practice which some companies and therefore some rodworkers carry out from time to time. This area of the rodworkers' trade has some unique hazards and problems which need to be addressed.

Instruction on post-tensioning is the task of trade training. However, the following section highlights hazards, precautions, and safe practices.

Types of Post-Tensioning Systems

There are various proprietary systems, but they can generally be divided into three types with features as follows:

1) **Strand Systems**

- Tendons made up normally of one or more 0.5-inch or 0.6-inch diameter 7-wire strand cables.
- Single strand tendons held by split conical wedges in individual anchorage castings (Figure 1.13).

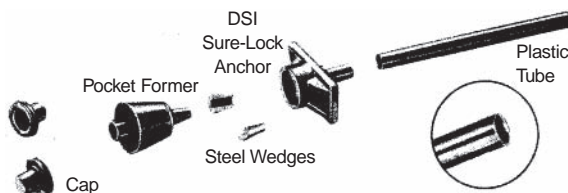


Figure 1.13 Single strand system

- Large multi-strand tendons can have from 31 to 55 strands (Figure 1.14).

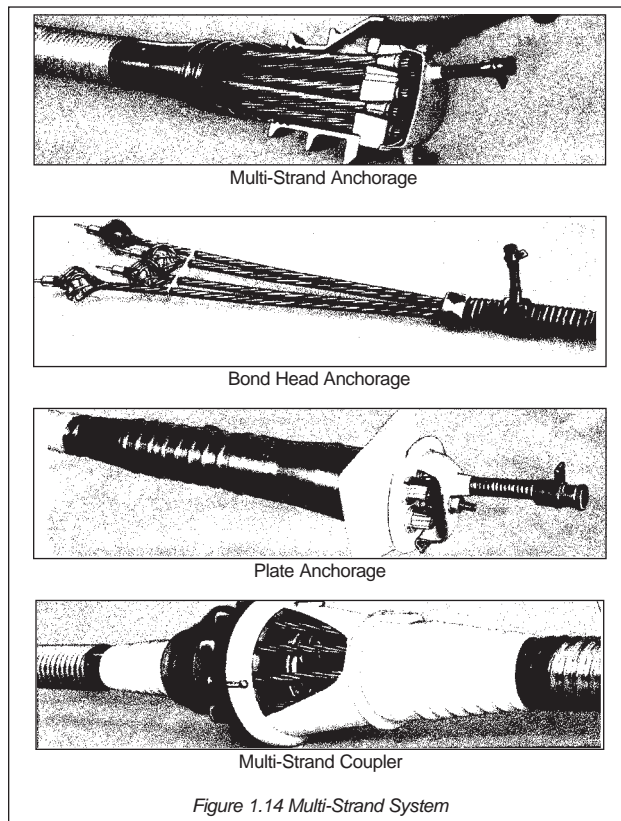
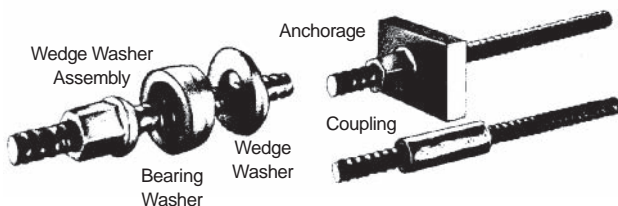


Figure 1.14 Multi-Strand System

- For multi-strand tendons, each strand is anchored by segmented steel wedges in an anchor head after passing through a "trumplate": a welded assembly consisting of a trumpet (tube) and a bearing plate.
- 2) **Bar Systems** (Figure 1.15)
 - High-strength bars (usually 1 inch to 1 3/8 inches) are used as tendons to apply compression to the concrete.
 - Threaded deformations in the bars allow anchorage, after stressing, using locknuts tightened against plate anchors.
 - The threaded deformations allow threaded couplers to



attach two bars end-to-end.

Figure 1.15: Bar Tendon with Plate Anchor

3) **Wire Systems** (Figure 1.16)

They have not been used in Canada since about 1980 but

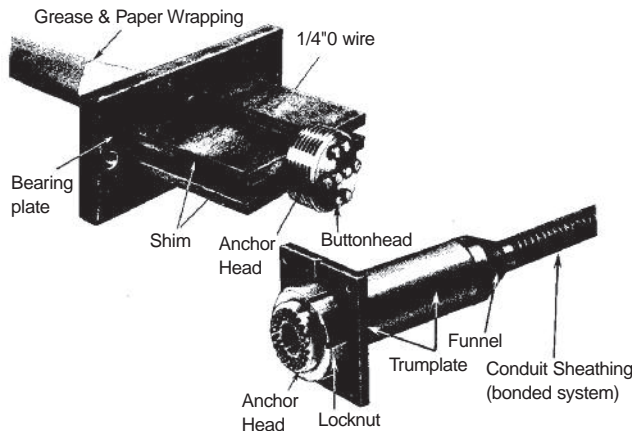


Figure 1.16: Wire Tendon Systems

could be encountered.

- Tendons made up of high tensile wires of 1/4 inch diameter.
- Can consist of 2 to 180 wires in a tendon, although commonly from 8 to 46 wires.
- Wires are frequently prefabricated with button heads and pass through a predrilled anchorage plate, especially at the fixed end.
- Wires are stressed and anchored at movable ends by shims or a locknut against a bearing plate or a trumplate.

Bonded versus Unbonded

The three systems described above can be divided into “bonded” and “unbonded” systems depending on whether the tendon ducts are filled with grout after stressing (bonded), or whether the tendons are greased and paper-wrapped or greased and plastic-covered (unbonded). Most systems are adaptable for bonded or unbonded construction. For “bonded” installations, the duct, or conduit, is often installed first and the tendons pushed or pulled through after the concrete is poured.

Although not restricted, unbonded systems are more likely to occur in floor-slab applications which contain a large number of small tendons. Bonded tendon systems tend to have some structural advantage and tend to be used in beams and large structural members which use a small number of relatively large tendons so that grouting costs are less.

Bonded Systems

- The tendons are encased in a flexible conduit or duct.
- Conduit is placed and concrete is poured around the conduit.
- The tendons are placed (if not already in the ducts), stressed, and anchored.
- Finally, expanding grout is pumped in to fill the void inside the duct or conduit.

Unbonded Systems

- The strand, wire, or bars are greased and paper-wrapped, or greased and plastic-covered.
- The concrete is poured for the member, beam, girder,

etc.

- The post-tensioning steel is then stressed and anchored.

Post-Tensioning Systems – Unloading, Handling, and Storage

The unloading, handling, storage, and distribution of all types of tendons for post-tensioning systems requires rodworkers to use their knowledge of good, safe rigging practices at all times.

General

- All types of systems, both bonded and unbonded, need to be handled with care to protect them from damage. Post-tensioning wires, strands, and bars are made of high-carbon steel, which makes them very susceptible to mechanical damage. A nick or kink can cause failure when tensioned to the high stresses required.
- Extreme care with welding or welding equipment is required around post-tensioning materials. Strand failure can result from a single drop of molten weld metal on the strand. High temperature exposure before or during tensioning can cause failure of strands during tensioning.
- Post-tensioning stressing equipment is susceptible to damage and is expensive, so it must be stored in a secure, clean, and dry place.
- Coils or racks of tendons or individual tendons must be stored in a clean, dry area, at least four inches off the ground or work surface, protected from exposure to weather, etc.

Strand Systems

- Strand post-tensioning is usually shipped to the jobsite in coils held by steel banding.
- The coils are usually about five feet in diameter and about four feet high. Each coil weighs about 1,500 to 2,000 lbs. and contains about 20 to 40 individual tendons.
- Nylon web slings are generally recommended for lifting strand tendon coils to avoid any damage to the wrapping.
- Place the coils, if possible, on the deck as close as possible to where they are to be used. The steel banding holding the coil together can be cut to allow the tendons to be separated.
- Individual tendons can then be hoisted from the coil and placed on dunnage at least four inches off the ground or work surface, adjacent to the beam form in which they will be used. Individual tendons can often be manually handled.

Bar Systems

- Bar tendons are shipped to the site in pre-cut lengths and general handling practices are similar to those for other types of tendons. Since bar tendons are similar in

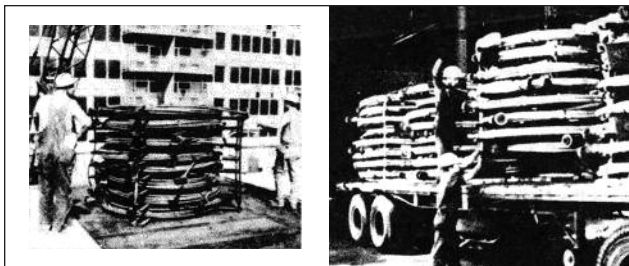


appearance to rebar, take care to identify and separate

them to avoid placing them as rebar by mistake.

Figure 1.17: Bundles of bar tendons stored on dunnage

Wire Systems



- General handling practices for wire tendons are similar to those for strand tendons but there are differences.
- Wire tendons are normally larger in diameter and weigh much more than individual strand tendons.
- Wire tendons are usually shipped on stacked metal rotatable shipping racks with metal arms separating individual tendons (Figure 1.18). Usually a number of tendons, up to eight to ten, are banded together with or without a rack.

Figure 1.18

Shipping racks help protect coiled tendons, simplify handling and placement.

- Individual wire tendons for use in slabs can usually be manually handled. Most individual beam wire tendons, however, weigh in excess of 200 lb. Hoisting equipment will be needed to lift them from the coil or shipping rack.
- Use nylon web slings to prevent damage to the sheathing.
- Take care when slinging wire tendon coils to balance the load with two or three slings and keep the coils level.
- **Hazard.** Do not attempt to cut the banding holding individual beam tendons in a coil. Each coiled wire tendon is like a large spring that, when released, will snap open and can cause serious injury. An uncoiling turntable must be used to control the uncoiling. Even though the spring forces may not be as high in wire tendons for use in slabs, take care when cutting banding.

Placing Pre-Stressing

There are many proprietary types of post-tensioning systems and each system—in some cases each application—has its own specific directions. The placement of pre-stressing strands in the beams, slabs, etc. varies and the supplier's or designer's instructions must be followed precisely in order for the system to perform properly.

If something does not check out, then let your foreman know immediately and the supplier can be contacted for clarification and correction.

Great care must be taken to follow post-tensioning placing

drawings.

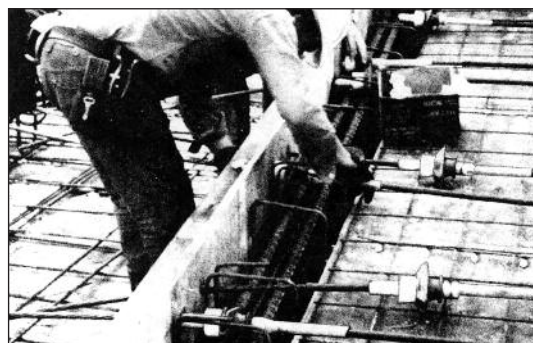
- Check that all tendons are accounted for and in the correct locations.
- Use extreme care to avoid damaging strands when they are being pulled into the bed with a tugger hoist or similar equipment.
- For bonded systems with ducts installed and stranded by a pusher or by pull-through be sure to
 - confirm that ducts are secure and continuously connected between anchorages
 - cordon off area between pusher and strand cage when in use
 - keep workers away from the front of the opposite anchorage to which the strand is pushed.
- Ensure that any added rebar needed to resist local stressing forces has been placed.

Strand Tendons

- The operation of uncoiling strand tendons can usually be accomplished by two rodworkers: one holding the end, while the other uncoils tendon on the deck.
- The tendon profile in the forms is accomplished by



correct placement of slab bolsters, high chairs, and



support bars. It is recommended that support bars for slab post-tensioning tendons be placed flat on the deck first at the proper spacing. After the tendons are rolled out, the support bars should be lifted and the individual chairs placed.

- Check conduit, plastic or paper-wrap, for rips or tears. These must be repaired with the tape supplied by the post-tensioning manufacturer (Figure 1.19). If concrete leaks in, it can affect proper wedge seating or result in inaccurate stressing forces.



Figure 1.20
Rigging tendon with nylon slings being lowered on field tendon uncoiler

Figure 1.19
Taping around casting, connector, and strand
Rodworker attaching anchorage assembly to forms

Wire Tendons

- Individual wire tendons for use in slabs can often be manually handled. Most individual beam wire tendons, however, weigh in excess of 200 lb. Hoisting equipment will be needed to lift them from the coil or shipping rack (Figure 1.20).
- Use nylon web slings to prevent damage to the sheathing.
- Take care when slinging wire tendon coils to balance the load with two or three slings and keep the coils level.
- **Hazard.** Do not attempt to cut the banding holding

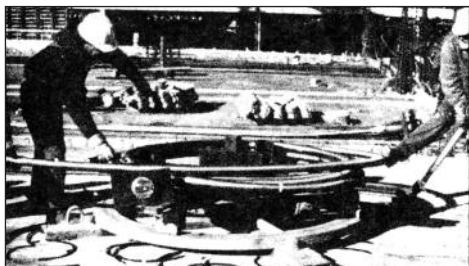


Figure 1.21
Cutting bands progressively, and crew of rodworkers
using the uncoiling turntable

individual beam tendons in a coil.

- Always use extreme caution when cutting individual tendon coils. Each coiled wire tendon is like a large spring that, when released, will snap open and can cause serious injury. It's best to use a "field tendon uncoiler" or, as a less-desirable choice, a field-fabricated, wooden-sided "explosion box". This is usually made from 2x10 boards in a box configuration larger than the coil diameter.
- Even though the spring forces may not be as high in wire tendons for use in slabs, always take care when cutting banding. Cut the bands progressively as the tendon is pulled out—never together (Figure 1.21).
- Always inspect and perform any necessary repairs to wire tendon sheathing to ensure that concrete cannot enter the void during the initial pour.
- As always, care must be taken to follow the placing drawings exactly and to make sure that the tendons conform to their specified profiles.

Placing Concrete

- During concrete pouring and placing, any damage done to the sheathing must be repaired before proceeding. This is necessary to achieve full strength in the final concrete member.
- For example, during vibration of the concrete, any contact of the vibrator with the sheathing can quickly cause damage.

Stressing Operations

After the concrete for the structural member (slab, beam, girder, etc.) is poured, it must be given sufficient time to cure and reach adequate strength to resist post-tensioning forces. At this point the tendons can be stressed. The force required to stress tendons comes from a hydraulic pump and jacks (or rams) and must be transferred through whatever anchoring devices the system uses.

- Visually inspect concrete around the anchor. It should be free of voids and honeycombing. Report any significant voids.
- Ensure that the jack is securely supported and that the operating axis of the jack and the tendon are aligned.
- Before starting tensioning, operate the jack pump to check that everything is working properly. Do not run the ram to the end of its stroke or close it down and continue to pump; damage can result.
- Ensure that no one stands at either end of the tendon or below the jack during the stressing operation. Never stand between the hoses.

The hydraulic pump and jack combinations come in a variety of types to suit each type of proprietary post-tensioning system and application. Each has its own configuration for jacking against bearing plates or anchors on the end of the concrete member to apply tension to strand, wire, or bar tendons. Figures 1.22 and 1.23 show the various parts and applications of a representative system, including the rigging required to support the jacks for use.

Grouting (for bonded systems)

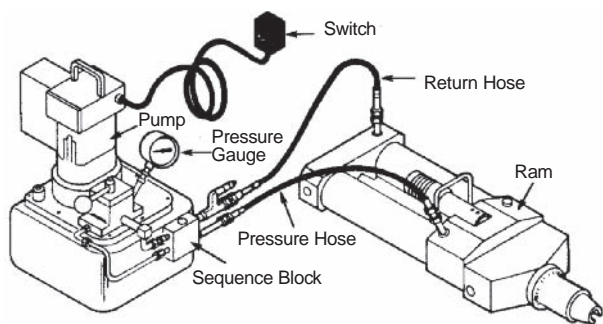
- Inspect the grout machine and the hoses to ensure

their proper operation. Look for items such as loose fittings and damaged hoses.

- Grout is corrosive. Always wear eye protection, face protection, and gloves when grouting.
- Rinse grout off skin with water.

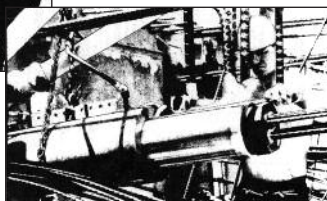
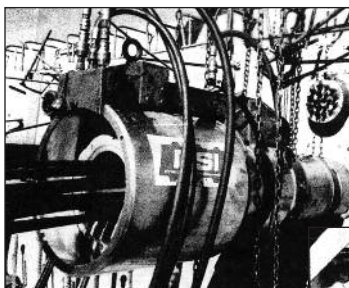
Good Work Practices

- Concrete quality and strength should be confirmed before stressing strands.
- Wedge plates must be shipped clean. Holes must be free of any dirt or rust. Wedges must be free of dirt and rust.
- Always follow manufacturer’s instructions on jack handling and use.
- Internal jack parts must correspond to tendon size requirements.
- All hoses, hose connections, valves, and other components must be checked for defects before each



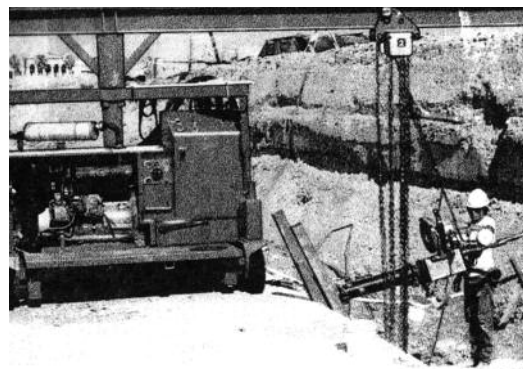
use and any questionable items repaired or replaced

- to meet manufacturer’s requirements.
- Free-cycle the jack for an operation check and bleed any air in accordance with the manufacturer’s instructions.



- Unattended hydraulic pumps must be unplugged.
- It is important that the grips and strands are perfectly clean. A small piece of dirt between a wedge (jaw) and the steel case (barrel) can cause failure or slippage of the strand.
- Follow manufacturer’s directions for cutting strands. Cutting with a burning torch can result in failures. Cutting off ends of a finished member may be permissible but remember—using a burning torch or welding equipment in the area can be dangerous for stressing operations.

Figure 1.22
Single Strand Jacking System



Multi-

strand

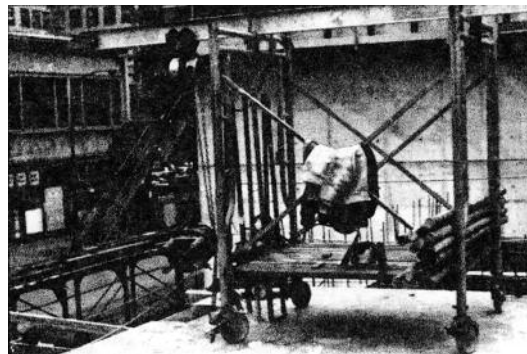


Figure 1.23: Hydraulic Pump and Jack Configurations

- Due to the heavy weight of jacks (50-ton jack with accessories weighs about 150 pounds, while a 200-ton weighs about 700 pounds), some rigging equipment will be needed to position and hold the jack for stressing operations.
- Use a crane if one is available. Another possible method of rigging the post-tensioning jacks is a rolling monorail system, such as shown in Figure 1.24.
- Sometimes a job-built jig can be used. Figure 1.25 shows a rolling scaffold used as trolley with an I-beam and chainfall arrangement being used to hoist, lower, and position a 250-ton jack. Note that counterbalance weights are needed with a good factor of safety to provide a safe platform.

Figure 1.24